

# ARIS PROCESS PERFORMANCE MANAGER PPM ARIS INTERFACE

VERSION 10.5.4  
MAY 2022

This document applies to ARIS Process Performance Manager Version 10.5.4 and to all subsequent releases.

Specifications contained herein are subject to change and these changes will be reported in subsequent release notes or new editions.

Copyright © 2000 - 2022 Software AG, Darmstadt, Germany and/or Software AG USA Inc., Reston, VA, USA, and/or its subsidiaries and/or its affiliates and/or their licensors.

The name Software AG and all Software AG product names are either trademarks or registered trademarks of Software AG and/or Software AG USA Inc. and/or its subsidiaries and/or its affiliates and/or their licensors. Other company and product names mentioned herein may be trademarks of their respective owners.

Detailed information on trademarks and patents owned by Software AG and/or its subsidiaries is located at <https://softwareag.com/licenses>.

Use of this software is subject to adherence to Software AG's licensing conditions and terms. These terms are part of the product documentation, located at <https://softwareag.com/licenses> and/or in the root installation directory of the licensed product(s).

This software may include portions of third-party products. For third-party copyright notices, license terms, additional rights or restrictions, please refer to "License Texts, Copyright Notices and Disclaimers of Third Party Products". For certain specific third-party license restrictions, please refer to section E of the Legal Notices available under "License Terms and Conditions for Use of Software AG Products / Copyright and Trademark Notices of Software AG Products". These documents are part of the product documentation, located at <https://softwareag.com/licenses> and/or in the root installation directory of the licensed product(s).

## Contents

1	General .....	1
2	Business process management .....	2
3	Procedure (taking ARIS Architect as an example) .....	3
3.1	Export from PPM .....	4
3.2	Import into ARIS Architect.....	4
4	EPC format in PPM .....	6
4.1	The EPC model type .....	6
4.1.1	Objects and connections .....	6
5	Aggregating process instances.....	8
5.1	Aggregation process.....	8
5.2	Identity criteria .....	8
5.2.1	Equality of functions.....	8
5.2.2	Equality of events.....	13
5.2.3	Equality of organizational units.....	14
5.2.4	Equality of connections .....	14
5.2.5	Equality of rules .....	14
5.2.6	Equality of attributes.....	15
5.3	Attribute calculation during the aggregation process .....	15
6	Configure the ARIS product interface .....	17
6.1	Object definition and attribute type mapping.....	17
6.1.1	Object type transformation .....	19
6.1.2	Object symbol transformation.....	19
6.1.3	Connection type transformation .....	19
6.1.4	Attribute type transformation .....	20
6.1.4.1	Transformation rules .....	22
7	Customize the ARIS product interface .....	25
8	Legal information.....	27
8.1	Documentation scope.....	27
8.2	Support .....	27

## 1 General

This manual describes the configuration of the ARIS interface of PPM. Via this interface, aggregated or non-aggregated process instances in ARIS XML model format (AML) are exported from PPM and imported as EPC model types to an ARIS product, for example, ARIS Architect for further processing.

Please note that this guide is not intended to replace user or configuration training. It is a source of reference containing information that supplements the information provided in the manuals and online help.

More information on PPM is available in the PPM user interface under **PPM > Documentation**.

## 2 Business process management

ARIS Process Performance Manager enables you to export executed processes in an XML format that is suitable for subsequent import into an ARIS product, such as ARIS Architect.

This closes the BPM loop. Based on the recording, observation, and evaluation of business processes (controlling), the step to a new business process (redesign) is performed.

Processes exported from PPM can be transferred as a model EPC to an ARIS product. You can perform various actions, for example, a structural comparison between target and actual processes.

You can use the entire analysis functionality provided by an ARIS product (simulation, process cost management, model comparison, etc.) for imported EPCs.

### 3 Procedure (taking ARIS Architect as an example)

The export of processes from ARIS Process Performance Manager and the subsequent import to ARIS Architect comprises the following steps:

- Create an aggregated or non-aggregated EPC view in PPM
- Export of the displayed EPC in AML format (ARIS Modeling Language)

First, the PPM graph format is transformed into AML format. In a further step, the data structure of the PPM export file is converted into the AML data structure for the import to ARIS Architect.

- Import the AML file into ARIS Architect using the XML import interface

The following schema provides an overview of the functional process of creating an AML export file from PPM with subsequent import into ARIS Architect:

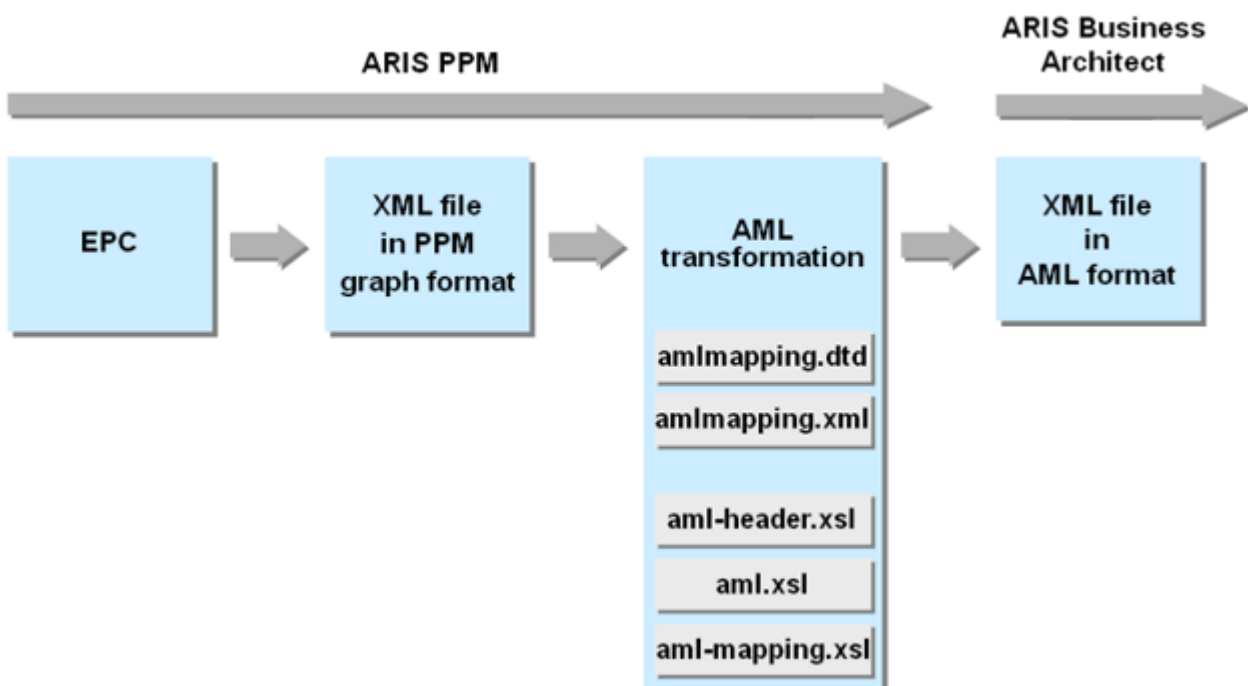

The AML transformation files supplied with the PPM installation carry out a standard transformation. Through appropriate customizing of the file **amlmapping.xml** you specify additional, client-specific attribute types, measures, and dimensions for the XML export (see chapter on **Customizing the ARIS Design interface** (page 25)).

## 3.1 Export from PPM

### Procedure

1. Display your analysis as an aggregated or non-aggregated EPC.
2. Right-click in the background of the EPC.
3. In the pop-up menu, click **Export as an XML file**.
4. Select the **ARIS XML Model Format (AML)** export format. For the export of an unaggregated EPC, specify whether you want to export assignments, as well.
5. Enter a file name and select the storage location for the file.

The EPC and, depending on the settings, any assignments are exported in AML format. The export includes all current process type and filter settings.

When aggregating process instances into an EPC, **PPM** calculates attributes that may be of interest for an evaluation in ARIS Architect (see chapter on **Attribute calculation during the aggregation process** (page 15)). Whether or not these attributes are included when importing to ARIS Architect depends on the specifications in the file **amlmapping.xml** (see chapters **Attribute type transformation** (page 20) and **Customizing the ARIS product interface** (page 25)).

## 3.2 Import into ARIS Architect

The XML file in AML format is then imported into ARIS Architect. The import is supported from version 7.0.

### Prerequisites

To guarantee an optimum data import, make sure that the following requirements are met before starting the import:

- You are logged in to the database with a sufficient method filter (**Entire method** is recommended).
- The database language selected matches the language of the exported PPM database content.
- You disabled the **Cancel on error** check box in the XML Import Wizard under **Settings**.
- If you are importing into a multilingual database, the names of all groups must be specified in all database languages.

**Procedure**

1. Log in to the relevant database taking into account the conditions stated.
2. In the pop-up menu of any group, select the menu item **Import** and then the option **XML files**.

In ARIS Architect, an EPC is created from the AML file, including assigned processes, if applicable.

You can also use the entire analysis functionality provided by ARIS Architect (simulation, process cost accounting, model comparison, etc.) with the imported models.

Messages and notes on the import process are output in a separate window, the **XML import log**:

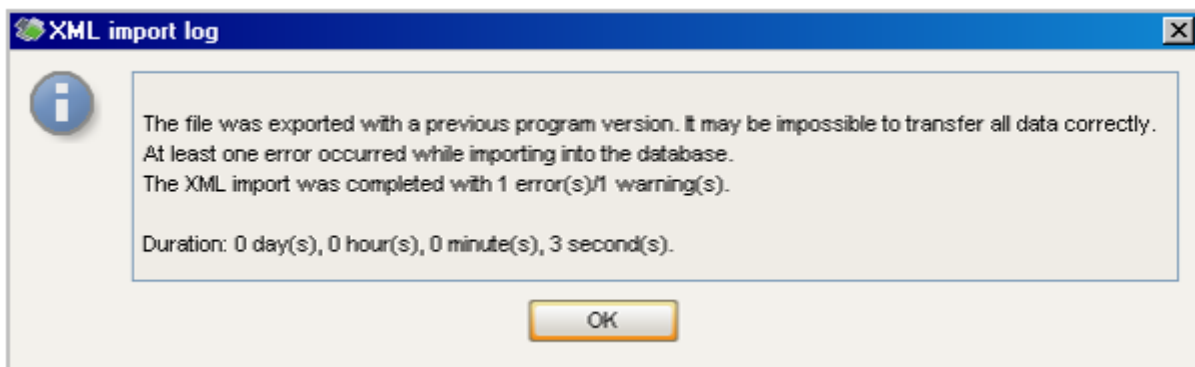



## 4 EPC format in PPM

The EPC format in PPM is similar to the EPC format in ARIS Architect. However, only a reduced number of object and connection types are available in PPM.

### 4.1 The EPC model type

An event-driven process chain (EPC) is a model type used to graphically describe the chronological sequence of a performance delivery process. The event-driven process chain is based on the following assumptions:

- Each activity within a process is triggered by a commercially relevant change of state of an information object.
- The outcome of any activity can entail a commercially relevant change of state of an information object.

The state of a commercially relevant information object is described graphically using an event. Functions are used for the graphic representation of activities.

Linking events and functions in series and connecting these objects with directed connections represents the control flow of the process graphically. As an event can trigger several functions and, in turn, a function can have several events as its result, AND, OR or EXCLUSIVE OR connections (rules) are branches in the process path. They illustrate the logical relationship that exists between the sequenced objects.

Organizational units can be assigned to a function. An organizational unit describes the group of processors in the company which executes the function in question. Organizational units are linked to the relevant function using connections.

EPCs are used in PPM to represent processes, so-called process instances actually executed in the past.

#### 4.1.1 Objects and connections

An object is the graphic representation of states, activities and organizational elements in a model, for example. Each object is assigned to an object type. Object types characterize the types of objects. In PPM, the Event, Function, Organizational unit and **Rule** object types are available.

Objects are linked with each other by connections. For each object type, the connection types by which it can be linked to other object types are defined. Two connection types are

available in PPM: The **executes** connection type between organizational units and functions and the **follows** connection type between events, functions and rules.

Rules describe the logical relationship which exists between several incoming or outgoing connections of an object. The **AND, OR, and EXKLUSIVE OR** rules are available in PPM.

## 5 Aggregating process instances

An aggregated EPC in PPM represents the average behavior of the underlying, actually executed process instances. You can use an aggregated EPC to evaluate behavioral patterns in business processes and analyze structural differences.

An aggregated EPC is created by aggregating several process instances. During aggregation, the EPCs, attributes and measures of the individual process instances are merged. The aggregation of process instances is associated with simplification and therefore with a loss of information.

The structure of an aggregated EPC essentially corresponds to the EPC structure of an individual process instance.

### 5.1 Aggregation process

During aggregation, all objects and connections of the selected process instances are transferred into the aggregated EPC. Objects or connections that meet specific identity criteria are merged into a single object or connection. This merge only transfers identical attributes of the objects or connections.

All process and function measures are calculated as attributes of the aggregated EPC and the aggregated functions.

### 5.2 Identity criteria

The following criteria exist to establish whether EPC elements are identical (objects, connections):

#### 5.2.1 Equality of functions

PPM functions are equal if their object names (**AT\_OBJNAME**) are identical. The spelling is case-sensitive.

#### INCLUDE ORGANIZATIONAL UNITS WHEN AGGREGATING FUNCTIONS

For the aggregation process, you can also specify that the names of the executing organizational units are to be taken into account as an equality criterion. This setting is specified in the configuration file **EPC\_settings.properties** in the client configuration directory:

EPC\_USE\_ORGUNIT\_FOR\_COMPRESS = true

This setting corresponds to the enabled check box **Create function occurrence for each organizational unit** in the EPC view options of the PPM interface.

If organizational units are considered in the aggregation, measure values, probabilities, and frequencies in the aggregated EPC can be uniquely assigned to a particular organizational unit. This can be useful for subsequent evaluations in ARIS Architect (for example, simulation).

The default value for this setting is **false**, that is, organizational units are not taken into account when aggregating functions.

### AGGREGATION CRITERIA

- It is important for the aggregation result of functions including organizational units, which of the following criteria you select for the aggregation of organizational units: In the **Process analysis** module of the PPM interface, organizational units are aggregated exclusively with the aggregation criterion **Object name (AT\_OBJNAME)**.
- In the **Interaction analysis**, you can also use as aggregation criterion an **organizational dimension (dimtype="OT\_ORG")** with a step width that can be set instead of the object name of the organizational unit for aggregating organizational units. In this case, organizational units are considered to be equal if the dimension values of the selected level match.

Please refer to the technical reference **PPM Customizing** to find out how to configure organizational dimensions.

### Example (temporary process instance aggregation in the PPM Process analysis module)

The two process instances shown are to be aggregated with or without taking into account organizational units as an equality criterion (aggregation criterion is **AT\_OBJNAME**):

Selected process instances

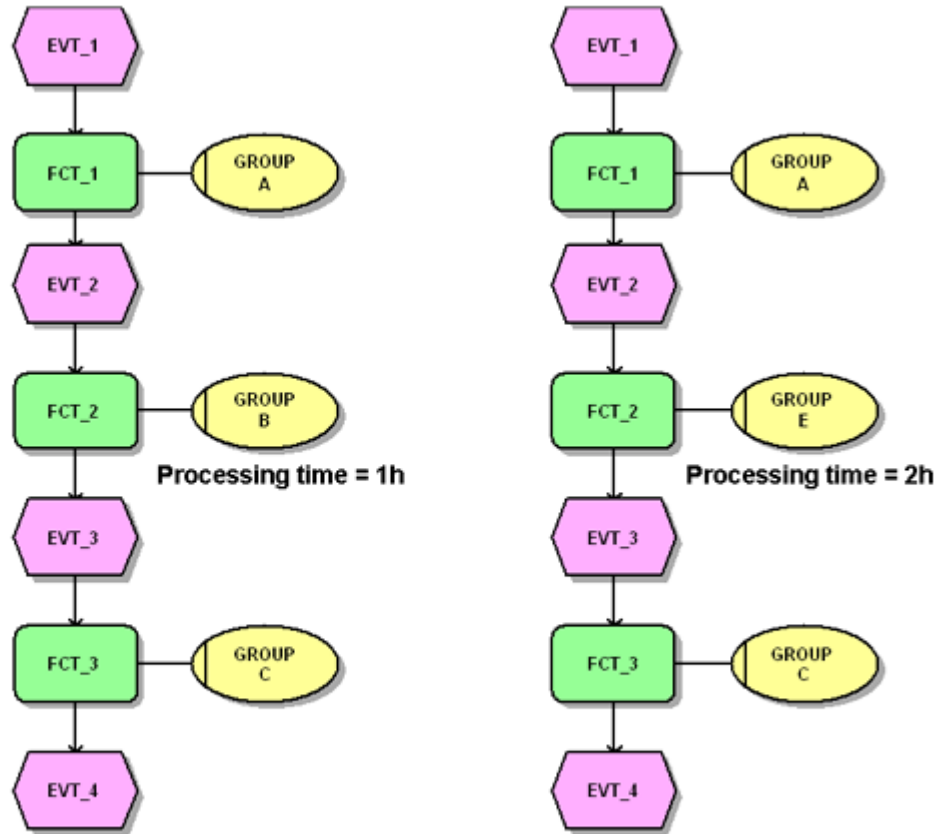

If the parameter **EPC\_USE\_ORGUNIT\_FOR\_COMPRESS = false**, functions with identical names are aggregated into a single function and the set union of all different organizational units specified for the functions are linked to the aggregated function by a connection. The **FCT\_2** functions are aggregated into a single function:

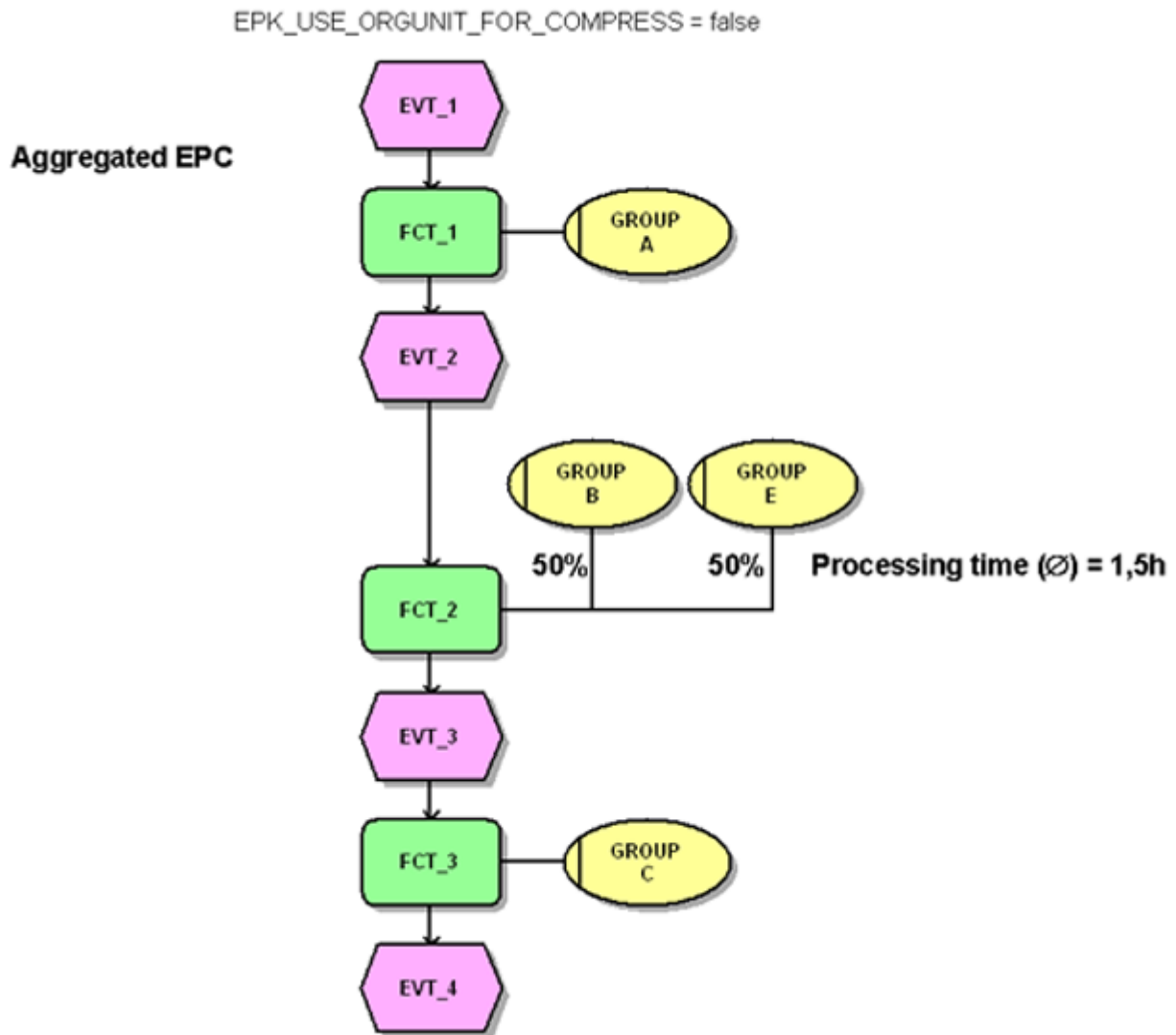

If the parameter **EPC\_USE\_ORGUNIT\_FOR\_COMPRESS = true**, functions with the same name that differ in respect of the assigned organizational units are not merged:

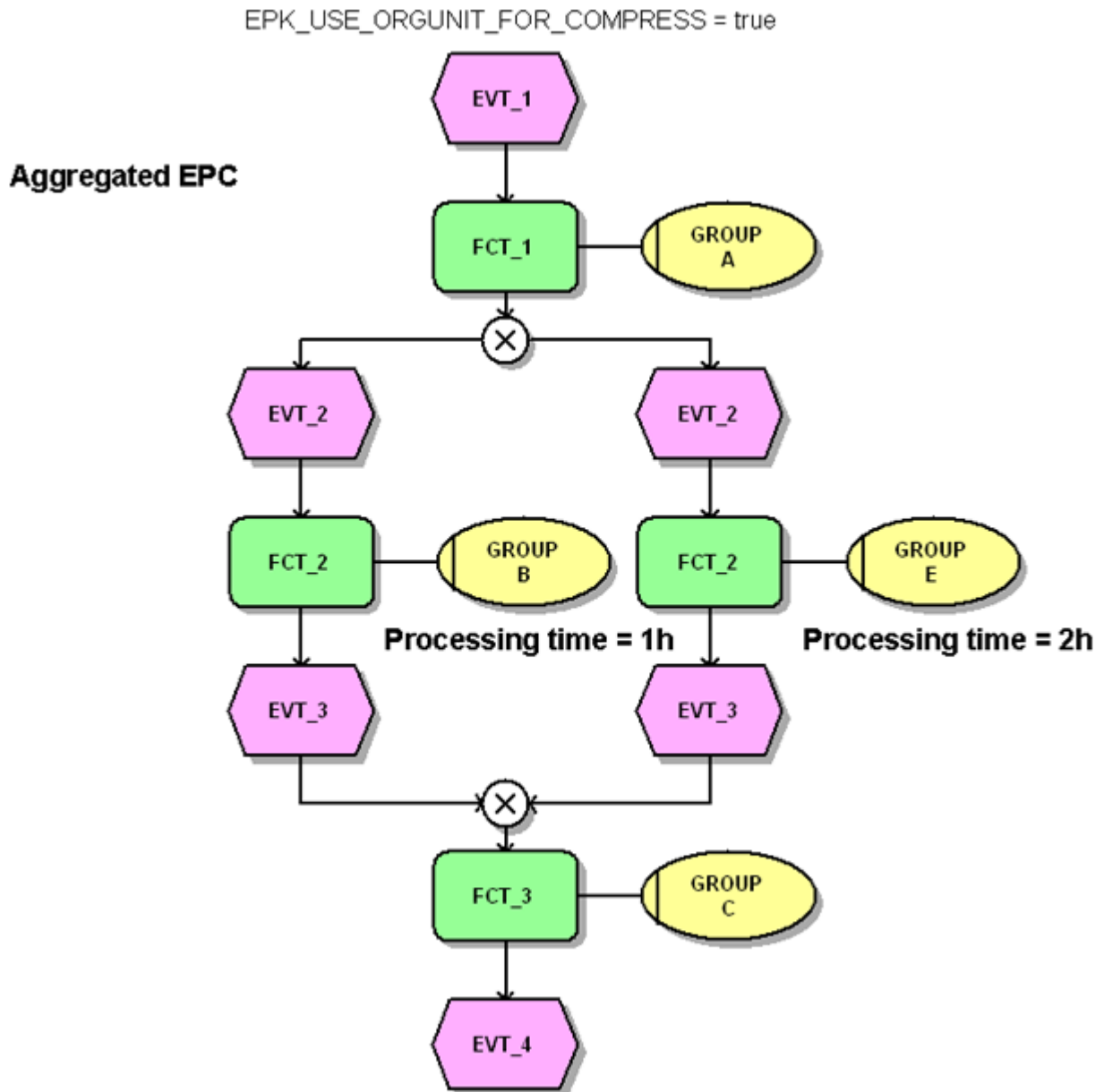

## 5.2.2 Equality of events

Events are identical if their names (**AT\_OBJNAME** attribute type) are identical. The spelling is case-sensitive. If the events have preceding and/or following functions, at least one of the functions preceding or following the events must be identical. Possible rules between events and functions are not taken into account in the equality check.

### Example

The two process instances shown are to be aggregated:

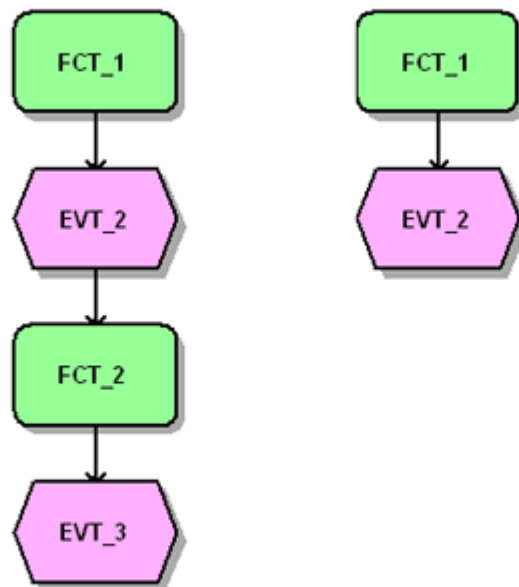



In the aggregated EPC, the two **EVT\_2** events are not merged because although both events are preceded by the same function, they are not followed by at least one identical function:

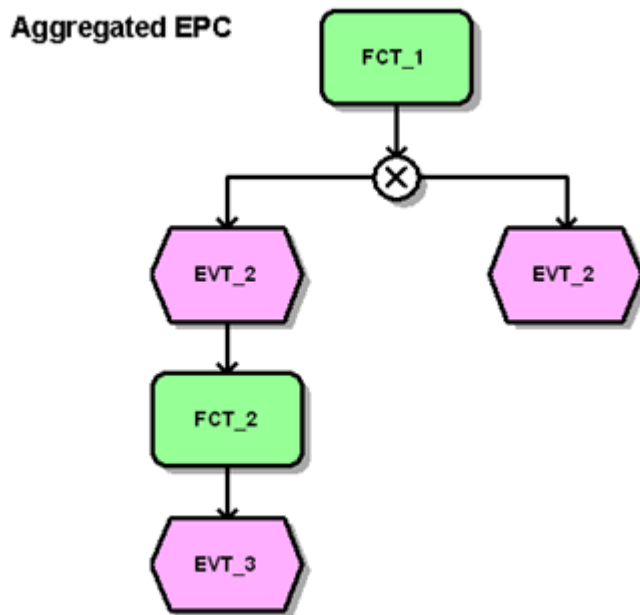

### 5.2.3 Equality of organizational units

Organizational units are identical if their names (**AT\_OBJNAME** attribute type) are identical and if they are assigned to the same function object. The spelling is case-sensitive.

### 5.2.4 Equality of connections

Connections are identical if they have the same connection type and their source and target objects are identical.

### 5.2.5 Equality of rules

Rules are identical if at least one preceding or following object of the rules is identical. Rules that may precede or follow the rules are not taken into account in the equality check.

## 5.2.6 Equality of attributes

Attributes are identical if they are of the same attribute type, if the attribute values match, and if the attribute values are located at the same object.

## 5.3 Attribute calculation during the aggregation process

In addition to all measures, the attributes listed below are also calculated by default during aggregation.

- **AT\_COUNT\_INSTANCES** (number of aggregated instances)

This attribute is calculated at the aggregated EPC and all functions and events and all connections of the **follows** type (CXN\_FOLLOWS) as the total of the attribute values of the process instances, objects, or connections to be aggregated. For the corresponding process attribute, this is the number of aggregated process instances (normally the number of processes). For the corresponding object attribute of functions and events, it is the number of functions or events merged, and for the corresponding connection attribute the number of connections merged.

- **AT\_PROBABILITY** (probability)

This attribute is calculated for all connections that run from a branching rule to an event. The quotient of  $AT\_COUNT\_INSTANCES(\text{connection}) / AT\_COUNT\_INSTANCES(\text{rule})$  is calculated. This specifies the probability of a particular path being followed.

- **AT\_AVG\_EXECFREQ** (average processing frequency)

This attribute is calculated for all connections and objects for which **AT\_COUNT\_INSTANCES** exists. The quotient of  $AT\_COUNT\_INSTANCES(\text{object, connection}) / AT\_COUNT\_INSTANCES(\text{EPC})$  is calculated. It specifies the average frequency with which a particular object or a particular connection occurs in each process instance.

- **AT\_COUNT\_PROCESSINGS** (number of executions)

This attribute is calculated for all functions, organizational units, and connections of the **executes** type (CXN\_UNDIRECTED). The total of the attribute values of the objects and connections to be aggregated is calculated. It specifies the frequency with which the relevant function, organizational unit or connection occurs in the aggregated EPC.

- **AT\_REL\_FREQUENCY** (relative frequency)

This attribute is calculated for all connections of the **executes** type (CXN\_UNDIRECTED).  
The quotient of  
 $AT\_COUNT\_PROCESSINGS (connection) / AT\_COUNT\_PROCESSINGS (function)$  is  
calculated. It specifies the relative frequency with which the organizational unit has  
executed the function.

## 6 Configure the ARIS product interface

During the AML export, the objects, connections, and attributes in an EPC in PPM graph format are converted into the corresponding EPC elements in the notation of the ARIS product you are using, for example, ARIS Architect. This is done using the files **amlmapping.dtd** and **amlmapping.xml** and the style sheet files **aml.xsl**, **aml-header.xsl**, and **aml-mapping.xsl**.

The transformation files supplied with PPM are located in the client-specific directory **<PPM installation directory>\server\bin\work\data\_ppm\config\<client>\report\xsl**. The configuration of the attribute type mapping file **amlmapping.xml** can be extended (see **Customizing the ARIS product interface** (page 25)).

The following chapters describe the content of the supplied file **amlmapping.xml**.

### 6.1 Object definition and attribute type mapping

The file **amlmapping.xml** is structured as follows:

XML element/ XML attribute	Description
amlmapping	List of mapping information
attrdefmapping	List of attribute type mappings specifying which attribute types are created for which elements (process, objects, connections)
graphmap	Mapping of process attributes
objmap	Mapping of object attributes
edgemap	Mapping of connection attributes
attrdefmap	Mapping of an attribute type. Content (#PCDATA) is the API name of the ARIS Architect attribute type.
attrdefmap ppmtyp	Identifier of the PPM attribute type.
attrdefmap mapping	Name of the transformation rule
objmap ppmtyp	PPM object type
objmap mapping	Name of the transformation rule

XML element/ XML attribute	Description
edgemap ppmsrctype	Source object type in PPM, for example, OT_ORG
edgemap ppmtargettype	Target object type in PPM, for example, OT_FUNC
currencymapping	Transformation of currencies
currencymap	Mapping for a currency. The content is the corresponding ARIS Architect attribute value type number (AVT), for example, 331 for EUR.
currencymap ppmttype	Name of the currency in PPM (for example, EUR, USD)
objdefmapping	Mapping of object types
objdefmap	Mapping of an individual object type (see chapter <b>Object type transformation</b> (page 19)). Content (#PCDATA) is the API name of the object type in ARIS Architect.
objoccmapping	Mapping of object symbols (see chapter <b>Object symbol transformation</b> (page 19))
objoccmmap	Mapping of an individual object symbol. Content (#PCDATA) is the API name of the object symbol in ARIS Architect.
edgedefmapping	Mapping of connection types
edgedefmap	Mapping of an individual connection type. Content (#PCDATA) is the API name of the connection type in ARIS Architect.
edgedefmap ppmsrctype	Source object type in PPM
edgedefmap ppmtargettype	Target object type in PPM
edgedefmap ppmcxntype	Connection type in PPM (CXN_FOLLOWS, CXN_UNDIRECTED)

## 6.1.1 Object type transformation

The PPM object types are converted into the corresponding ARIS Architect object types in accordance with the following table:

Object type in PPM	Object type in ARIS Architect
OT_EVT	OT_EVT
OT_FUNC	OT_FUNC
OT_ORG	OT_ORG_UNIT
OT_RULEAND	OT_RULE
OT_RULEOR	OT_RULE
OT_RULEXOR	OT_RULE

## 6.1.2 Object symbol transformation

The PPM objects are converted into the corresponding ARIS Architect object symbols in accordance with the following table:

Object type in PPM	Object symbol in ARIS Architect
OT_EVT	ST_EV
OT_FUNC	ST_FUNC
OT_ORG	ST_ORG_UNIT_2
OT_RULEAND	ST_OPR_AND_1
OT_RULEOR	ST_OPR_OR_1
OT_RULEXOR	ST_OPR_XOR_1

## 6.1.3 Connection type transformation

Depending on the type of relationship between the linked object types, the two PPM connection types are transformed into the different ARIS Architect connection types (activates, creates, carries out, etc.).

## 6.1.4 Attribute type transformation

PPM attribute types are converted by default into the corresponding ARIS Architect attribute types in accordance with the following table using the specified transformation rule. With appropriate customizing, you can adapt the attribute type transformation (see **Customizing the ARIS product interface** (page 25)).

### PPM OBJECT TYPE "FUNCTION"

PPM attribute type	Attribute type ARIS Architect	Rule
AT_OBJNAME	AT_NAME (name)	text
AT_KI_FBZ	AT_TIME_AVG_PRCs (average processing time)	timespan
AT_KI_FBZSP	AT_TIME_MAX_PRCs (maximum processing time)	timespan
AT_KI_FLZ	AT_TIME_AVG_WAIT (average wait time)	timespan
AT_KI_FDLZ	AT_CYCLE_TIME_AVG (average processing time)	timespan
AT_KI_FDLZSP	AT_CYCLE_TIME_MAX (maximum cycle time)	timespan
AT_KI_FEDFRE Q	AT_USG_FACT (usage factor)	float
AT_LS	AT_TIME_AVG_PRCs (average processing time)	timespan
AT_KI_FDLZWK	AT_TIME_AVG_THRG (avg. cycle time)	timespan
AT_KI_FLZWK	AT_USER_ATTR1 (user attribute text 1)	timespan
AT_PKS_S	AT_USER_ATTR7 (user attribute float 1)	float
AT_PKS_R	AT_USER_ATTR7 (user attribute float 1)	float

## PPM OBJECT TYPE "ORGANIZATIONAL UNIT"

PPM attribute type	Attribute type ARIS Architect	Rule
AT_OBJNAME	AT_NAME (name)	text
AT_NUM_OF_EMPL	AT_NUM_OF_EMPL (Number of employees)	int
AT_COSTRATE	AT_COST_RATE (Cost rate)	costrate

## PPM OBJECT TYPE "EVENT"

PPM attribute type	Attribute type ARIS Architect	Rule
AT_OBJNAME	AT_NAME (name)	text

## EPC

Attribute type PPM	Attribute type ARIS Architect	Rule
AT_ID	AT_NAME_FULL (full name)	text
AT_PROCTYPE GROUP	AT_NAME (name)	text
AT_KI_PDLZ	AT_TIME_TOT_AVG (average total time)	timespan
AT_KI_PNUM	AT_COMP_MDLS_NUM (number of aggregated models)	float
AT_KI_PINT	AT_REF_NUM_1 (measure 1)	float
AT_KI_PEDFREQ	AT_REF_NUM_2 (measure 2)	float
AT_COUNT_PROCESSINGS	AT_REF_NUM_3 (measure 3)	int



## CONNECTIONS

Attribute type PPM	Connection progression	Attribute type ARIS Architect	Rule
AT_REL_FREQUEN CY	From OT_ORG to OT_FUNC	AT_REL_FRQ (Relative frequency)	float
AT_PROBABILITY	From branching rule (OT_RULEAND, OT_RULEOR, OT_RULEXOR) to OT_EVT	AT_PROB (probability)	float

### 6.1.4.1 Transformation rules

Transformation of attribute types also entails a conversion of the data type. The following table provides an overview of the transformation rules for converting the data type of PPM attribute types into the corresponding data type in AML format. The transformation rules are defined in the file **aml-mapping.xsl** and referenced in the files **amlmapping.dtd** and **amlmapping.xml**.

Transformation rule	Attribute Base Type (ABT) in ARIS Architect	Name in ARIS Architect
text	ABT_MULTILINE	n lines
float	ABT_FLOAT	Floating point number
int	ABT_RANGEINTEGE R	Integer value range
timespan	ABT_COMBINED	Combined, for example, <b>Cycle time</b> attribute type at functions
costrate	ABT_COMBINED	Combined

Transformation rule	Attribute Base Type (ABT) in ARIS Architect	Name in ARIS Architect
frequency	ABT_INTEGER	Integer representing a frequency per day, for example, <b>Frequency day</b> at events
cost	ABT_COMBINED	Combined

The following table describes the individual transformation rules:

Transformation rule	Description
text	Any free-form text that is copied unchanged from the PPM attribute type to the ARIS Architect attribute type.
float	The result is a floating point number (positive/negative) rounded off to two decimal places. Only the content of the PPM attribute type up to the first space is copied to the ARIS Architect attribute type. This truncates all PPM units. For example, the PPM attribute value <b>12.3 HOUR</b> becomes the ARIS Architect attribute value <b>12.3</b> .
int	The result is an integer value within an upper and lower limit specified by ARIS Architect. The content of the PPM attribute type is rounded off to an integer, that is, floating point numbers from PPM can also be transformed. The PPM attribute type may not have a unit, that is, the attribute value may only contain a number.
timespan	PPM attribute types of the <b>TIMESPAN</b> or <b>FACTORY-TIMESPAN</b> data type are transformed into an ARIS Architect attribute type of the <b>ABT_COMBINED</b> data type.

Transformation rule	Description
costrate	<p>Transformation of cost rates: The result is a combined value for the ARIS Architect attribute type with the data type <b>ABT_COMBINED</b> as costs per hour in the corresponding currency.</p> <p>The currencies to be included can be specified using the <b>currencymapping</b> XML element in the file <b>amlmapping.xml</b>. The default values are <b>EUR</b> and <b>USD</b>.</p>
frequency	<p>The PPM attribute value of the <b>FREQUENCY</b> data type is transformed into an integer specifying the corresponding frequency per day.</p>
cost	<p>Transformation of costs: A PPM attribute type of the <b>COST</b> data type is transformed into an ARIS Architect attribute type of the <b>ABT_COMBINED</b> data type. The result is a combined value in the corresponding currency.</p>

## 7 Customize the ARIS product interface

If necessary, the attribute type transformation can be adapted to the extended client-specific configuration of the PPM system.

### Warning

Do not change anything in the specified mapping information for object types (**objdefmapping** XML element), object symbols (**objoccmapping** XML element) and connections (**edgedefmapping** XML element), as this may result in an incorrect XML import into ARIS Architect.

To transfer client-specific data from the PPM system to an ARIS product (for example, ARIS Architect), it is necessary to customize the attribute type transformation.

To do this, adapt the mapping of the attribute types (**attrdefmapping** XML element) by adding the corresponding sections to the file **amlmapping.xml** (XML elements **graphmap**, **objmap**, and **edgemap**).

Each entry for the **attrdefmap** XML element uses the specified transformation rule (see chapter on **Transformation rules** (page 22)) to transform a single PPM attribute type of a particular object type into the specified ARIS Architect attribute type.

The procedure for customizing the interface is as follows:

1. Check at which element (EPC, object, connection) the corresponding attribute type is specified in the PPM system and what its data type is. Consider which attribute type is to be used at the corresponding element in ARIS Architect.
2. Select the appropriate transformation rule.
3. Select a suitable ARIS Architect attribute type that you want to transform the PPM attribute type into. You should take into account the data type (ABT = attribute base type) of the ARIS Architect attribute type, into which the selected PPM attribute type is to be transformed.

Note that the ARIS Architect method does not permit every attribute type mapping. If required, use the method help in ARIS Architect to specify the relevant target attribute type. In ARIS Architect, predefined attribute types are assigned to a particular fixed data type and are only permitted for certain object types.

4. Add the configured entry to the file **amlmapping.xml**.

Any attribute type calculation rules for measures or dimensions must be correctly specified in the measure configuration.

## Example

You want to include the function attribute type **AT\_KI\_BSP** that you have configured in PPM in the XML import to ARIS Architect.

You have defined a calculation rule for this attribute type, in which a time span is calculated.

To do this, adapt the attribute type transformation (text in bold) as follows in the file **amlmapping.xml**:

```
<?xml version="1.0" encoding="UTF-8"?>
<!DOCTYPE amlmapping SYSTEM "amlmapping.dtd">
<amlmapping>
  <attrdefmapping>
    <graphmap>
      ...
    </graphmap>
    <objmap ppmtype="OT_EVT">
      ...
    </objmap>
    <objmap ppmtype="OT_ORG">
      ...
    </objmap>
    <objmap ppmtype="OT_FUNC">
      ...
      <attrdefmap ppmtype="AT_OBJNAME"
        mapping="text">AT_NAME
      </attrdefmap>
      ...
      <b><attrdefmap ppmtype="AT_KI_BSP"
        mapping="timespan">AT_TIME_MIN_ORNT
      </b></attrdefmap>
    </objmap>
    ...
  </attrdefmapping>
  ...
</amlmapping>
```

In the example, the ARIS Architect attribute type **Minimum orientation time (AT\_TIME\_MIN\_ORNT)** of the **ABT\_COMBINED** data type has been selected. The attribute type is assigned to the **Times/Orientation time** attribute type group for functions. You can use the **timespan** transformation rule to assign time spans from the PPM system to the attribute type.

The PPM client server and user interface do not need to be restarted after adapting the file **amlmapping.xml** as the file is read before every XML export.

## 8 Legal information

### 8.1 Documentation scope

The information provided describes the settings and features as they were at the time of publishing. Since documentation and software are subject to different production cycles, the description of settings and features may differ from actual settings and features. Information about discrepancies is provided in the Release Notes that accompany the product. Please read the Release Notes and take the information into account when installing, setting up, and using the product.

If you want to install technical and/or business system functions without using the consulting services provided by Software AG, you require extensive knowledge of the system to be installed, its intended purpose, the target systems, and their various dependencies. Due to the number of platforms and interdependent hardware and software configurations, we can describe only specific installations. It is not possible to document all settings and dependencies.

When you combine various technologies, please observe the manufacturers' instructions, particularly announcements concerning releases on their Internet pages. We cannot guarantee proper functioning and installation of approved third-party systems and do not support them. Always follow the instructions provided in the installation manuals of the relevant manufacturers. If you experience difficulties, please contact the relevant manufacturer.

If you need help installing third-party systems, contact your local Software AG sales organization. Please note that this type of manufacturer-specific or customer-specific customization is not covered by the standard Software AG software maintenance agreement and can be performed only on special request and agreement.

### 8.2 Support

If you have any questions on specific installations that you cannot perform yourself, contact your local Software AG sales organization (<https://www.softwareag.com/corporate/company/global/offices/default.html>). To get detailed information and support, use our websites.

If you have a valid support contract, you can contact **Global Support ARIS** at: **+800 ARISHELP**. If this number is not supported by your telephone provider, please refer to our Global Support Contact Directory.

## ARIS COMMUNITY

Find information, expert articles, issue resolution, videos, and communication with other ARIS users. If you do not yet have an account, register at ARIS Community.

## SOFTWARE AG EMPOWER PORTAL

You can find documentation on the Software AG Documentation website (<https://empower.softwareag.com/>). The site requires credentials for Software AG's Product Support site **Empower**. If you do not yet have an account for **Empower**, send an e-mail to [empower@softwareag.com](mailto:empower@softwareag.com) with your name, company, and company e-mail address and request an account.

If you have no account, you can use numerous links on the TECHcommunity website. For any questions, you can find a local or toll-free number for your country in our Global Support Contact Directory and give us a call.

## TECHCOMMUNITY

On the **TECHcommunity** website, you can find documentation and other technical information:

- Use the online discussion forums, moderated by Software AG professionals, to ask questions, discuss best practices, and learn how other customers are using Software AG technology.
- Access articles, code samples, demos, and tutorials.
- Find links to external websites that discuss open standards and web technology.
- Access product documentation, if you have **TECHcommunity** credentials. If you do not, you will need to register and specify **Documentation** as an area of interest.

## EMPOWER (LOGIN REQUIRED)

If you have an account for **Empower**, use the following sites to find detailed information or get support:

- You can find product information on the Software AG Empower Product Support website.
- To get information about fixes and to read early warnings, technical papers, and knowledge base articles, go to the Knowledge Center.
- Once you have an account, you can open Support Incidents online via the eService section of Empower.
- To submit feature/enhancement requests, get information about product availability, and download products, go to Products.

## SOFTWARE AG MANAGED LEARNINGS

Get more information and trainings to learn from your laptop computer, tablet or smartphone. Get the knowledge you need to succeed and make each and every project a success with expert training from Software AG.

If you do not have an account, register as a customer or as a partner.