



## **Process Governance**

# **MODELING CONVENTIONS FOR PROCESS GOVERNANCE**

Version 10.0 - Service Release 2

October 2017

This document applies to ARIS Version 10.0 and to all subsequent releases.

Specifications contained herein are subject to change and these changes will be reported in subsequent release notes or new editions.

Copyright © 2010 - 2017 [Software AG](#), Darmstadt, Germany and/or [Software AG](#) USA Inc., Reston, VA, USA, and/or its subsidiaries and/or its affiliates and/or their licensors.

The name [Software AG](#) and all Software AG product names are either trademarks or registered trademarks of [Software AG](#) and/or [Software AG](#) USA Inc. and/or its subsidiaries and/or its affiliates and/or their licensors. Other company and product names mentioned herein may be trademarks of their respective owners.

Detailed information on trademarks and patents owned by [Software AG](#) and/or its subsidiaries is located at <http://softwareag.com/licenses>.

Use of this software is subject to adherence to Software AG's licensing conditions and terms. These terms are part of the product documentation, located at <http://softwareag.com/licenses> and/or in the root installation directory of the licensed product(s).

This software may include portions of third-party products. For third-party copyright notices, license terms, additional rights or restrictions, please refer to "License Texts, Copyright Notices and Disclaimers of Third Party Products". For certain specific third-party license restrictions, please refer to section E of the Legal Notices available under "License Terms and Conditions for Use of Software AG Products / Copyright and Trademark Notices of Software AG Products".

These documents are part of the product documentation, located at <http://softwareag.com/licenses> and/or in the root installation directory of the licensed product(s).

## Contents

1	Text conventions.....	1
2	Modeling conventions for process automation .....	2
2.1	What objects and symbols are relevant to Process Governance? .....	2
2.1.1	Events .....	2
2.1.2	Event (process instance started) .....	3
2.1.3	Event (process instance terminated) .....	3
2.1.4	Timer event .....	3
2.1.5	Functions .....	4
2.1.6	Automated task .....	6
2.1.7	Human task .....	6
2.1.8	Notification .....	9
2.1.9	Live message .....	9
2.1.10	Operators .....	10
2.1.11	Organizational elements .....	11
2.1.12	Other .....	12
2.2	What models are relevant to Process Governance? .....	13
2.2.1	Value-added chain diagram .....	13
2.2.2	EPC - Process flow .....	13
2.2.3	EPC - Satellites .....	14
2.2.4	Application system type diagram .....	16
2.2.5	Access diagram .....	16
2.2.6	IE Data model .....	17
2.2.7	Organizational chart .....	18
2.3	How to resolve modeling errors .....	19
2.3.1	How to resolve modeling error [600.14] .....	20
3	Automation data flows .....	22
3.1	Start context .....	23
3.2	Human task .....	26
3.2.1	General data mapping .....	26
3.2.2	Data mapping for user selection .....	31
3.2.3	Data mapping for lists .....	32
3.3	Notification and live message .....	33
3.4	ARIS Business services .....	35
3.4.1	Add - Models/Objects/Groups .....	35
3.4.2	Compare - Model versions .....	39
3.4.3	Copy - Database .....	44
3.4.4	Create - 1 directory/group .....	46
3.4.5	Create - 1 model .....	48
3.4.6	Create - 1 object .....	50
3.4.7	Create - Database .....	54
3.4.8	Create - Dynamic ARIS Publisher export .....	56
3.4.9	Create - Report .....	60
3.4.10	Create - Shortcut(s) .....	65
3.4.11	Create - Static ARIS Publisher export .....	67
3.4.12	Create - Version .....	70
3.4.13	Delete - Database .....	73
3.4.14	Delete - Dynamic ARIS Publisher export .....	75
3.4.15	Delete - Group .....	77
3.4.16	Delete - Model(s) .....	79
3.4.17	Delete - Object(s) .....	81
3.4.18	Delete - Temporary files .....	83

3.4.19	Lock - Model(s)/Object(s) .....	84
3.4.20	Move - Models/Objects (within database) .....	86
3.4.21	Reorganize - Database .....	88
3.4.22	Retrieve - 1 (superior) directory attribute .....	90
3.4.23	Retrieve - 1 attribute in multiple elements .....	92
3.4.24	Retrieve - ARIS user group attributes .....	94
3.4.25	Retrieve - Current technical version of model(s) .....	96
3.4.26	Retrieve - Element(s) based on Attribute(s) .....	98
3.4.27	Retrieve - Element(s) based on GUID(s) .....	100
3.4.28	Retrieve - Group path .....	102
3.4.29	Retrieve - Lock status (model(s)/object(s)) .....	103
3.4.30	Retrieve - Model(s) and/or object(s) in scope .....	106
3.4.31	Retrieve - Multiple attributes from 1 item .....	108
3.4.32	Retrieve - Versionable database .....	111
3.4.33	Unlock - Model(s)/Object(s) .....	113
3.4.34	Write - 1 attribute to multiple elements .....	115
3.4.35	Write - Multiple attributes to 1 element .....	117
3.5	ARIS Connect Publishing Service .....	120
3.5.1	Add – Comment in Collaboration .....	120
3.5.2	Retrieve - Link in ARIS Connect .....	122
3.6	ARIS document storage .....	124
3.6.1	Create - Document .....	124
3.6.2	Create - Folder .....	126
3.6.3	Delete Document(s) .....	127
3.6.4	Download - Document .....	128
3.6.5	Lock - Document(s) .....	129
3.6.6	Move - Document(s) .....	130
3.6.7	Retrieve - Document(s) by ID .....	131
3.6.8	Retrieve - Document(s) by link .....	133
3.6.9	Unlock - Document(s) .....	135
3.6.10	Update - Document(s) .....	136
3.6.11	Update - Metadata of 1 document .....	137
3.6.12	Update - Metadata of multiple documents .....	138
3.7	Process Governance Service .....	139
3.7.1	Retrieve - Process instance ID .....	139
3.8	User management .....	140
3.8.1	Assign - Privilege to user .....	140
3.8.2	Assign - Privilege to user group .....	141
3.8.3	Assign - Product license to user .....	143
3.8.4	Assign - Product license to user group .....	145
3.8.5	Assign - User to group .....	147
3.8.6	Create - User .....	149
3.8.7	Create - User group .....	150
3.8.8	Delete - User .....	151
3.8.9	Delete - User group .....	152
3.8.10	Retrieve - Architect user .....	153
3.8.11	Retrieve - Connect Designer user .....	154
3.8.12	Retrieve - Process Board user .....	155
3.8.13	Retrieve - User belongs to user group .....	156
3.8.14	Retrieve - User groups of user .....	158
3.8.15	Retrieve - User information .....	159
3.8.16	Retrieve - User selection empty .....	161
3.8.17	Write - User information .....	162
3.9	Local services .....	163
3.9.1	Compare - Boolean values .....	163

3.9.2	Compare - Future timestamps .....	164
3.9.3	Compare - String .....	165
3.9.4	Compare - Time attributes .....	166
3.9.5	Compare - Value empty .....	168
3.9.6	Create - Change number(s).....	169
3.9.7	Create - Human task log .....	170
3.9.8	Retrieve - Link (design) .....	172
3.9.9	Retrieve - Number (highest/lowest).....	174
3.10	Operators in the data flow .....	175
3.10.1	Numerical operators .....	175
3.10.1.1	Add .....	175
3.10.1.2	Subtract .....	176
3.10.1.3	Multiply .....	177
3.10.1.4	Divide.....	177
3.10.2	Comparison operators.....	178
3.10.2.1	Equal to .....	178
3.10.2.2	Not equal to .....	178
3.10.2.3	Greater than .....	179
3.10.2.4	Greater than or equal to .....	180
3.10.2.5	Less than .....	181
3.10.2.6	Less than or equal to .....	182
3.10.3	Boolean operators .....	183
3.10.3.1	AND operator .....	183
3.10.3.2	OR operator .....	183
3.10.3.3	NOT operator .....	184
3.10.4	What are operators for collections?.....	185
3.10.4.1	Select item by ID .....	185
3.10.4.2	Select item by position .....	186
3.10.4.3	Create collection .....	186
3.10.4.4	Determine size of collection.....	187
3.10.4.5	Create intersection of collections.....	187
3.10.4.6	Format lines .....	188
3.10.4.7	Validate collection .....	188
3.10.4.8	Merge collections .....	189
3.10.5	What are document operators? .....	190
3.10.5.1	Get document by path .....	190
3.10.5.2	Get document metadata .....	191
3.10.5.3	Filter documents .....	192
3.10.5.4	Generate http link for document .....	192
3.10.6	Data elements .....	193
3.10.6.1	Path to ARIS Process Board.....	193
3.10.6.2	Get timestamp.....	194
3.10.7	Miscellaneous operators .....	195
3.10.7.1	Check whether user exists .....	195
3.10.7.2	Determine user via e-mail/login name .....	196
3.10.7.3	Get committed resource.....	197
3.10.7.4	Get participant name.....	198
3.10.7.5	Concatenate .....	198
3.10.7.6	Convert timestamp or date to human readable text.....	199
3.10.7.7	Data XOR operator .....	200
3.10.7.8	Calculate time .....	201

3.11	Constants .....	202
3.12	Variables .....	203
3.12.1	Instance variable .....	203
3.12.2	Process variable .....	203
3.12.3	System variable .....	203
3.12.4	Examples .....	204
4	Disclaimer .....	207

## 1 Text conventions

Menu items, file names, etc. are indicated in texts as follows:

- Menu items, key combinations, dialogs, file names, entries, etc. are displayed in **bold**.
- User-defined entries are shown **<in bold and in angle brackets>**.
- Single-line example texts (e.g., a long directory path that covers several lines due to a lack of space) are separated by ↵ at the end of the line.
- File extracts are shown in this font format:  
This paragraph contains a file extract.
- Warnings have a colored background:

### Warning

This paragraph contains a warning.

## 2 Modeling conventions for process automation



These modeling conventions support you in creating compliant models for process automation. This ensures, for example, that all required items and information are available to guarantee automatic transformation of a BPM process into a BPMN diagram.

### 2.1 What objects and symbols are relevant to Process Governance?

The following tables list the object types/symbol types that are interpreted by Process Governance.

#### 2.1.1 Events

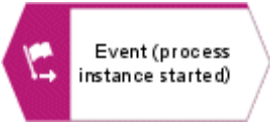
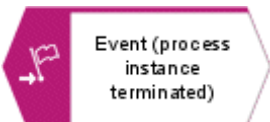
More symbols and attributes than those listed here may exist for the object types. But Process Governance only interprets the ones listed. The attributes for Process Governance are contained in the **Process automation** attribute type group.

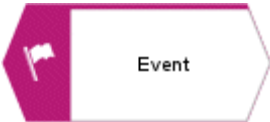
Symbol shape/ Symbol name	Description	Attributes (process automation)
 Event (process instance started)	Triggers automation and generates the process instance.	No object-specific attributes (process automation)
 Event (process instance terminated)	Terminates the process instance.	No object-specific attributes (process automation)
 Timer event	Delays the next process step until the specified Process Governance time.	No object-specific attributes (process automation)
 Event	Describes the status.	No object-specific attributes (process automation)



### 2.1.2 Event (process instance started)

In an EPC, the following modeling conventions must be observed for the **Event (process instance started)** object symbol:

- The EPC assigned to the function in the superior value-added chain diagram must have exactly one **Event (process instance started)** object symbol.
- The **Event (process instance started)** object symbol may be modeled only once in a Process Governance process.

### 2.1.3 Event (process instance terminated)

In an EPC, the following modeling conventions must be observed for the **Event (process instance terminated)** object symbol:







- In the Process Governance process, there must be at least one **Event (process instance terminated)** object symbol.
- As the **Event (process instance terminated)** object symbol terminates the process instance, it must be the last object in the Process Governance process.
- The process can continue after the **Event (process instance terminated)** object symbol if, for example, steps follow that are not relevant to Process Governance.





### 2.1.4 Timer event

An event can depend on a certain point in time. In this case, an object of the **Event** type with the **Timer event** object symbol has to be used, and the **Date** attribute must be assigned to this event in the data flow diagram.

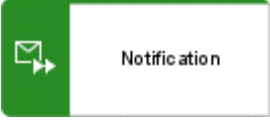
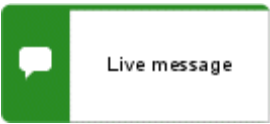
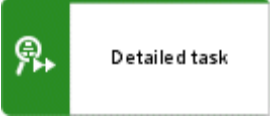
## 2.1.5 Functions

More symbols and attributes than those listed here may exist for the object types. But Process Governance only interprets the ones listed. The attributes for Process Governance are contained in the **Process automation** attribute type group.

Symbol shape/ Symbol name	Description	Attributes (process automation)
 	<p>The process assigned to this function triggers the automation and generates the process instance. There is one symbol for opening the process and one symbol for closing it.</p>	No object-specific attributes (process automation)
 	<p>The process assigned to this function is supported by Process Governance. There is one symbol for opening the process and one symbol for closing it.</p>	No object-specific attributes (process automation)
	<p>If the task is ready for editing, it is displayed to the executor in charge in ARIS Process Board. The user can call the dialog and perform the task.</p>	No object-specific attributes (process automation)
	<p>If a task is to be processed, a software service operation type is called, e.g., an ARIS Web service. No action by a user is required.</p>	No object-specific attributes (process automation)
	<p>If persons are to be notified, an e-mail is automatically sent to the persons defined as notification recipients in the process model.</p>	No object-specific attributes (process automation)
	<p>If the user that triggered the process instance is to be notified, a message is automatically displayed in ARIS.</p>	No object-specific attributes (process automation)
	<p>Used for the interpretation of the assigned EPC by Process Governance.</p>	No object-specific attributes (process automation)

Symbol shape/ Symbol name	Description	Attributes (process automation)
 <span data-bbox="225 331 419 383">Detailed task (starts automation)</span>		
 <span data-bbox="225 577 400 607">Process interface</span>	<p>Relevant to the superior EPC or value-added chain diagram. Defines which processes belong to the entire executable governance process.</p>	<p>No object-specific attributes (process automation)</p>
 <span data-bbox="225 801 395 831">Process module</span>  <span data-bbox="225 936 400 987">System function (actual)</span>  <span data-bbox="225 1084 363 1113">Function</span>	<p>All other function symbols can be used in value-added chain diagrams/ EPCs. They are relevant to Process Governance if they are assigned a data flow diagram in an EPC.</p>	<p>No object-specific attributes (process automation)</p>

## 2.1.6 Automated task

In an EPC, each function of the **Automated task** symbol type must be linked with exactly one software service operation type via the **supports** connection.

## 2.1.7 Human task

In an EPC, the following modeling conventions must be observed for functions of the **Human task** type:

- A single dialog is assigned.
- It may be linked to a maximum of one information carrier of the **E-mail** symbol type via the **provides input for** connection.

If no e-mail has been modeled, no e-mail is sent, but the task to be performed is still displayed as a task in ARIS Process Board.

Various options exist for assigning human tasks to an executor.

### ASSIGNMENT WITH ORGANIZATIONAL ELEMENTS AND THE CONNECTION 'CARRIES OUT'

The human task must be linked to exactly one automation-relevant organizational element by the **carries out** connection. Possible organizational elements here are Person, Role, Position, and Organizational unit.

Organizational elements of the **Role** or **Organizational unit** type must be assigned at least one user who is activated for process automation, unless the Commit employee (page 14) attribute is set and/or a predefined user exists.

If a human task is assigned an organizational element of the **Person** type, the user must be activated for process automation.

If no active user is found the escalation manager is notified by e-mail. If no escalation manager is defined, the human task is given the status **Failed**.

You can optionally specify the **Executor selection** and **Commit employee** attributes for the **carries out** connection. The default values are **Only one required** and **Same executor(s) required (commit employee)**.

In the data flow it is possible to assign other data that will overwrite the assignment of the organizational element described above. This should be avoided unless the **Executor selection** attribute at the **carries out** connection has the value **All from preselection**.

## ASSIGNMENT USING THE 'COMMIT EMPLOYEE' ATTRIBUTE

The attribute value for all human tasks within a process instance, which are assigned to the same organizational element (**Role** or **Organizational unit**), must be specified with either **Commit employee** or **Segregation of duties**. Only the attribute value **No policy** can be combined with one of the other attribute values within an instance.

### SAME EXECUTOR(S) REQUIRED (COMMIT EMPLOYEE)

The **Commit employee** attribute with the value **Same executor(s) required (commit employee)** is considered only if the value **Only one required** is selected for the **Executor selection** attribute. This corresponds to the default settings.

It ensures that the user who is editing the first task of the process instance also performs all further tasks. Only then do the tasks receive the status **Completed**. Nevertheless, these tasks can be passed on to other executors in ARIS Process Board (delegate, specify substitution).

#### Example

The first task in a process instance is assigned to the **QM** user group. This means that all persons assigned to this organizational element in the organizational chart can edit the first task. If, for example, the user Peter Smith edits the first task, that user is assigned all other tasks in this process instance.

### OTHER EXECUTOR(S) REQUIRED (SEGREGATION OF DUTIES)

If segregation of duties is specified for the tasks of a process instance the tasks must be carried out by different executors. To ensure this, from the second human task in a process instance, the executor who already carried out a task in the process instance is excluded from execution. However, it is possible to pass on (delegate) the tasks in ARIS Process Board to an executor who has already carried out a task in the process instance.

### NO POLICY

Tasks whose **Commit employee** attribute has the value **No policy** can be carried out by all executors assigned via the organizational element.

If a chain of tasks for which **Commit employee** is specified is interrupted by a task with the attribute value **No policy**, the subsequent task with resource commitment is handled as though it were the first task in the process instance. This means that the task can again be carried out by any user from the assigned group and the resource commitment is specified again for the subsequent tasks.

#### Example

There are four tasks in a process instance, all of which are assigned to the **QM** user group, to which Peter Smith and Frank Brown belong. The first task can be carried out by both. Peter Smith is the one who carries out the task, for which **Commit employee** and **Only one required** are specified. Therefore, the second task is assigned to him, as well. No policy is specified for the third task. This means that both persons are assigned for execution again. This time, Frank Brown is faster and thus is assigned the fourth task, as well.

## ASSIGNMENT VIA THE DATA FLOW WITH THE ATTRIBUTE 'LOGIN OF THE PREDEFINED EXECUTOR'

With this attribute, the first executor of tasks in a process instance can be specified. If, in addition, the value **Same executor(s) required (commit employee)** is specified for the attribute **Commit employee**, the employee is specified for the entire instance.

This predefined executor must be activated for process automation and belong to the organizational element (**Role** or **Organizational unit**) that is assigned to the human task. The value **Only one required** must be selected for the **Executor selection** attribute. If these conditions are met, all other persons in this organizational element are not assigned any human tasks in this process instance.

## 2.1.8 Notification

In an EPC, the following modeling conventions must be observed for the **Notification** object symbol of the **Function** object type.

- It is linked to exactly one information carrier of the **E-mail** symbol type via the **provides input for** connection.
- It is linked to at least one organizational unit or role via the **must be informed about** connection.
- For an e-mail, at least the **Subject** and **Text** attributes must be specified.

## 2.1.9 Live message

It allows information to be sent within ARIS and not via the e-mail system. A user who has started a governance process does not need to exit ARIS and switch to another application in order to display messages. In an EPC, the following modeling conventions must be observed for live messages.

### MODELING WITH AN INFORMATION CARRIER

The following applies to the **Live message** object symbol of the **Function** object type:

- It is linked to a maximum of one **E-mail** (information carrier) object symbol via the **provides input for** connection.
- For an e-mail, at least the **Subject** and **Text** attributes must be specified.

### MODELING WITHOUT AN INFORMATION CARRIER

The following applies to the **Live message** object symbol of the **Function** object type:

If no information carrier is modeled, the input data for the live message must be modeled in the data flow. You can generate the information to be sent by a Web service, for example.

### MODELING WITH ORGANIZATIONAL ELEMENTS

The following applies to the **Live message** object symbol of the **Function** object type:





- It is linked to at least one automation-relevant organizational element via the **must be informed about** connection. Automation-relevant means that these are organizational elements that the convention (page 11) allows.
- The **Only inform people involved** and **Send e-mail notification as** attributes should be specified for the **must be informed about** connection.

If attributes are not specified, the default values are used, in other words:

- The **Only inform people involved** attribute value is **Yes**.
- The **Send e-mail notification as** attribute value is **Recipient**.

## 2.1.10 Operators

More symbols and attributes than those listed here may exist for the object types. But Process Governance only interprets the ones listed. The attributes for Process Governance are contained in the **Process automation** attribute type group.

Symbol shape/ Symbol name	Description	Attributes (process automation)
 XOR rule	Exactly one of the process paths must be followed.	No object-specific attributes (process automation)
 AND rule	All outgoing process paths must be followed.	No object-specific attributes (process automation)
 OR rule	At least one of the process paths must be followed.	No object-specific attributes (process automation)
 Termination rule	<p>The first process instance specifies the further procedure. All instances that follow are therefore deleted.</p> <p><b>Example</b></p> <p>Two persons are modeled in parallel as decision makers. If one person has made a decision, the following decision is deleted.</p>	No object-specific attributes (process automation)







## 2.1.11 Organizational elements

More symbols and attributes than those listed here may exist for the object types. But Process Governance only interprets the ones listed. The attributes for Process Governance are contained in the **Process automation** attribute type group.

### MAPPING ARIS ELEMENTS TO ARIS ADMINISTRATION ELEMENTS



When creating the executable process, the organizational elements of the Process Governance process are created in ARIS Administration. User groups are generated for organizational units, groups, roles, and positions in ARIS Administration (mapping) and users for persons. The escalation relationship from the organizational chart remains unchanged and is represented in ARIS Administration by the corresponding user group.

Symbol shape/ Symbol name	Description	Attributes (process automation)
 Organizational unit	Combines the task performers of the manpower. Organizational units are the performers of the tasks required to attain the business objectives.	External user (group) ID
 Group	Represents a grouping of employees/persons collaborating for a certain period of time in order to perform specific tasks (as a project group), for example.	External user (group) ID
 Position	The smallest identifiable organizational unit in a company. The responsibilities and authorities are specified in the relevant job description.	External user (group) ID
 Role	Represents a typification of individual employees who have the same properties, such as privileges or responsibilities.	External user (group) ID
 Internal person	Represents a specific employee of a company who can usually be identified by a personnel number.	<ul style="list-style-type: none"> <li>▪ E-mail address</li> <li>▪ External user (group) ID</li> <li>▪ Login</li> <li>▪ First name</li> <li>▪ Last name</li> <li>▪ Process Governance administrator</li> </ul>

## 2.1.12 Other

More symbols and attributes than those listed here may exist for the object types. But Process Governance only interprets the ones listed. The attributes for Process Governance are contained in the **Process automation** attribute type group.

### APPLICATION SYSTEM TYPE/IT FUNCTION TYPE

Symbol shape/ Symbol name	Description	Attributes (process automation)
 Software service type	Assigns software service operation types to the source code to run the IT operation.	No object-specific attributes (process automation)
 Software service operation type	Connects automated tasks to the source code to perform the task.	Script ID

### DIALOG

Symbol shape/ Symbol name	Description	Attributes (process automation)
 Screen	A human task can be performed only if it is connected to a dialog (screen).	No object-specific attributes (process automation)

### CLUSTER/DATA MODEL

Symbol shape/ Symbol name	Description	Attributes (process automation)
 Cluster	All relevant data objects are represented by clusters.	<ul style="list-style-type: none"> <li>▪ Type</li> <li>▪ Variable context (system, process, process instance)</li> </ul>

### INFORMATION CARRIER

Symbol shape/ Symbol name	Description	Attributes (process automation)
 E-mail	If a task is generated for a user, the user receives a corresponding notification, e.g., by e-mail, if this has been modeled. E-mails can also be sent to pass on information.	<ul style="list-style-type: none"> <li>▪ Subject</li> <li>▪ Text</li> </ul>

## 2.2 What models are relevant to Process Governance?

The following tables list the model types that are interpreted by Process Governance.

### 2.2.1 Value-added chain diagram

More symbols and connections may exist for the model other than those listed here. Process Governance only interprets the following symbols. The attributes for Process Governance are contained in the **Process automation** attribute type group.

No connections are interpreted in the value-added chain diagram.

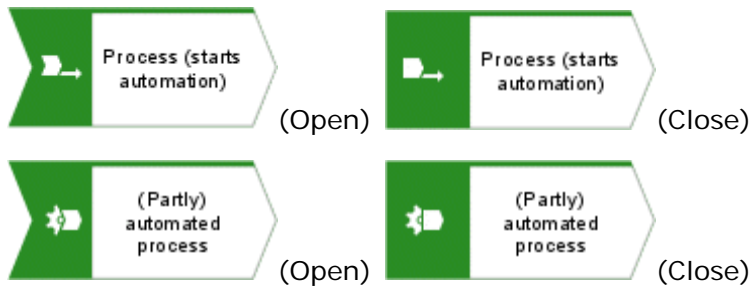

### 2.2.2 EPC - Process flow

All connections describing the chronological sequence are allowed.



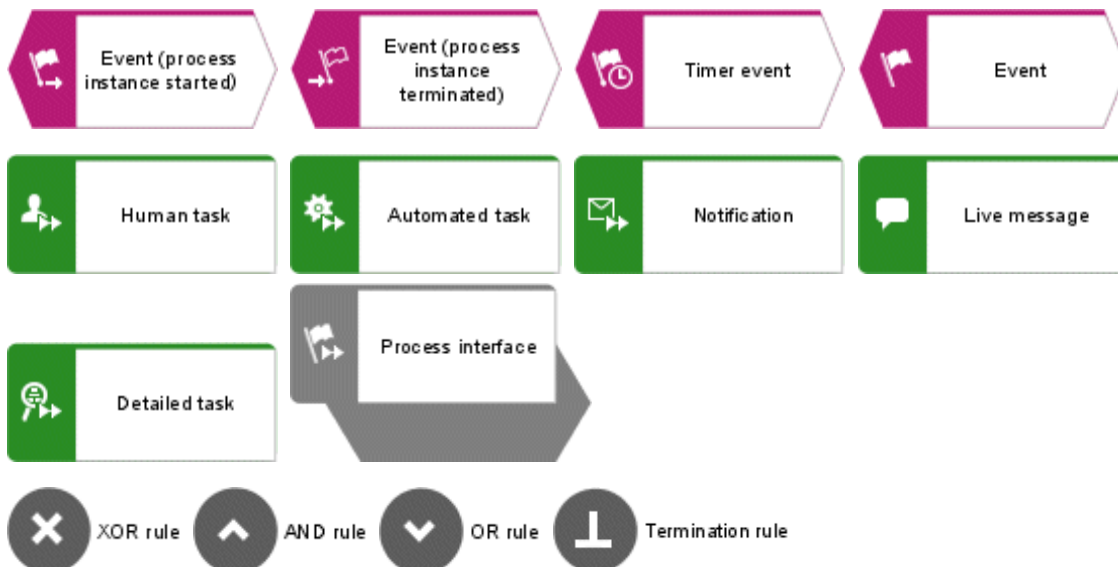







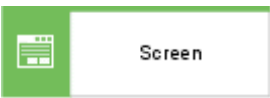

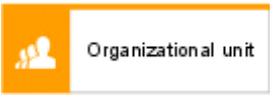
More symbols and connections may exist for the model other than those listed here. Process Governance only interprets the following symbols. The attributes for Process Governance are contained in the **Process automation** attribute type group.

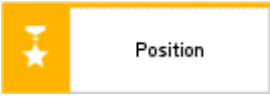
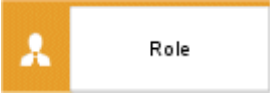



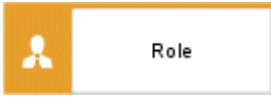
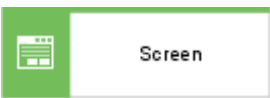



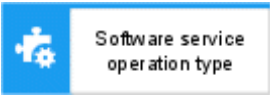

### 2.2.3 EPC - Satellites

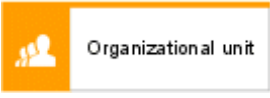
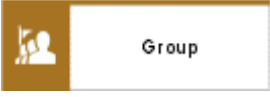
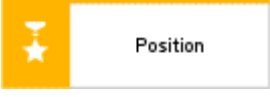
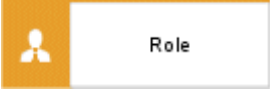
A satellite is an object that can be inserted in a model or diagram but is not a structurally relevant object in the model or diagram. For example, an object of the **Organizational unit** type is a satellite in an event-driven process chain (EPC). In a model of the **Organizational chart** type, on the other hand, an object of the **Organizational unit** type is a structurally relevant object.

More symbols and connections may exist for the model other than those listed here. Process Governance only interprets the following symbols. The attributes for Process Governance are contained in the **Process automation** attribute type group.

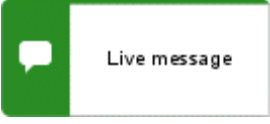
Source symbol	Connection	Target symbol	Connection attributes (process automation)
	<b>creates</b>		No object-specific attributes (process automation)
   	<b>carries out</b>		<ul style="list-style-type: none"> <li>▪ Executor selection                             <ul style="list-style-type: none"> <li>▪ Only one required</li> <li>▪ All from preselection</li> <li>▪ All required</li> <li>▪ Voting</li> </ul> </li> <li>▪ Commit employee</li> </ul>
	<b>is escalated to</b>	 	No object-specific attributes (process automation)
	<b>represents</b>		No object-specific attributes (process automation)
	<b>provides input for</b>		No object-specific attributes (process automation)

Source symbol	Connection	Target symbol	Connection attributes (process automation)
	<b>supports</b>		No object-specific attributes (process automation)
   	<b>must be informed about</b>		<ul style="list-style-type: none"> <li>▪ Only inform people involved</li> <li>▪ Send e-mail notification as                             <ul style="list-style-type: none"> <li>▪ Recipient</li> <li>▪ Cc</li> <li>▪ Bcc</li> </ul> </li> </ul>
	<b>provides input for</b>		No object-specific attributes (process automation)
	<b>provides input for</b>		No object-specific attributes (process automation)

## 2.2.4 Application system type diagram



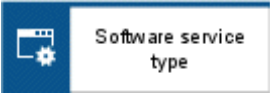
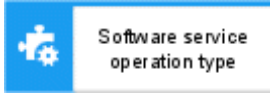

More symbols and connections may exist for the model other than those listed here. Process Governance only interprets the following symbols. The attributes for Process Governance are contained in the **Process automation** attribute type group.

Services (Web services or script services) are defined in the application system type diagram.

Source symbol	Connection	Target symbol	Connection attributes (process automation)
	<b>encompasses</b>		No object-specific attributes (process automation)

## 2.2.5 Access diagram

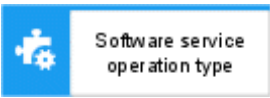
More symbols and connections may exist for the model other than those listed here. Process Governance only interprets the following symbols. The attributes for Process Governance are contained in the **Process automation** attribute type group. Services (Web or script services) are detailed in the access diagram.

Source symbol	Connection	Target symbol	Connection attributes (process automation)
	<b>is input for</b>		No object-specific attributes (process automation)
	<b>has as output</b>		No object-specific attributes (process automation)

## 2.2.6 IE Data model

More symbols and connections may exist for the model other than those listed here. Process Governance only interprets the following symbols. The attributes for Process Governance are contained in the **Process automation** attribute type group.











Only the **Cluster** symbol is interpreted in the IE Data model. No connections are interpreted.

The IE Data model is used to model a variable catalog. Variables should be used in governance workflows only if required. For the standard data flow between the various activities, the activities themselves should be used as input. The data should not be unnecessarily stored intermediately in variables as this may have a massive impact on the entire performance of the governance workflow.



## 2.2.7 Organizational chart

More symbols and connections may exist for the model other than those listed here. Process Governance only interprets the following symbols. The attributes for Process Governance are contained in the **Process automation** attribute type group.

	 Organizational unit	 Group	 Position	 Role	 Internal person
 Organizational unit	<b>is superior</b>	<b>is assigned to</b>	<b>is composed of</b>	<b>is composed of</b>	---
 Group	---	<b>is superior</b>	<b>is composed of</b>	<b>is composed of</b>	---
 Position	<b>is organization manager for</b>	<b>is organization manager for</b>	---	<b>occupies</b>	<b>occupies</b>
 Role	<b>is organization manager for</b>	<b>is organization manager for</b>	---	---	<b>is generalization of</b>
 Internal person	---	---	---	---	---



## 2.3 How to resolve modeling errors

If you generate the executable process for non-compliant models, error messages are displayed in the **Messages on executable processes** bar in a list. Using this information, you can eliminate the errors and perform the action again.

You can perform additional actions using the pop-up menu. To open and display the relevant model, click **Navigate to object**. Activities or connections containing errors are marked with a warning symbol. Activities are also highlighted in color.

Use the **Show details** option in the pop-up menu to display additional information:

- ID and name of the affected model
- IDs and names of the affected objects
- IDs of connections that are not permitted or that have caused the error
- Detailed description of the error

The information can be copied to the clipboard by selecting **Copy** in the pop-up menu.

Selecting **Delete all** in the pop-up menu removes all messages.

The **Navigate to object** and **Show details** options in the pop-up menu are available only if the message was generated by automatic validation of the BPMN diagram. These options are not executable for messages that were generated by the transformation or archiving.

### 2.3.1 How to resolve modeling error [600.14]

If the error message [600.14] is displayed, you can resolve the error by inserting a dummy object, as described below.

Full error message:

Generating the executable process failed. [600.14] Object '<object name>' of type '<object type>' may have only one outgoing connection.

#### MODELING ERROR 1: THE PROCESS ENDS AFTER A VARIABLE ASSIGNMENT OR XOR RULE

Solution: Open the epc model and add at least one dummy function at the process end.

Example:

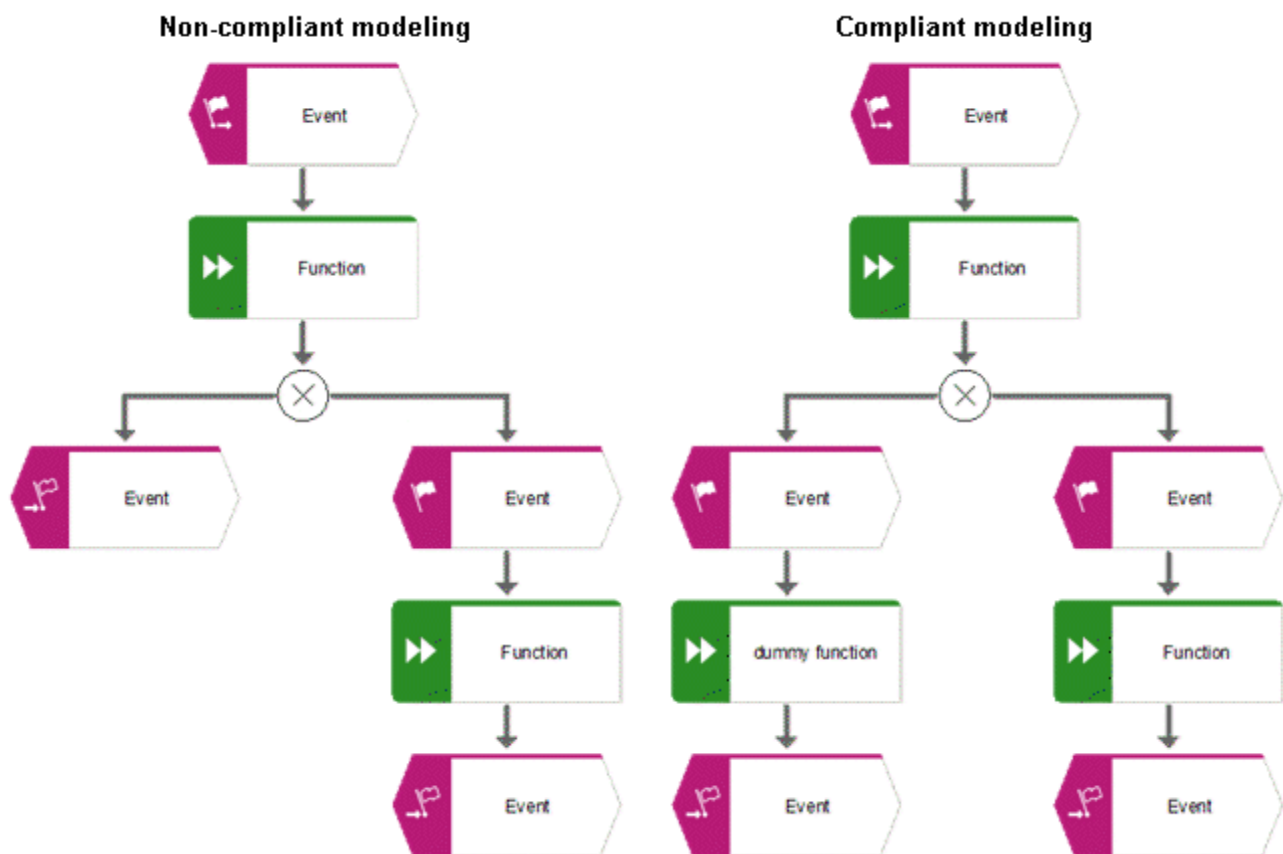

**MODELING ERROR 2: AN XOR SPLIT IS FOLLOWED BY AN EVENT AND AN XOR JOIN**

Solution: Open the epc model and add a dummy function between the event and the XOR join.

Example:

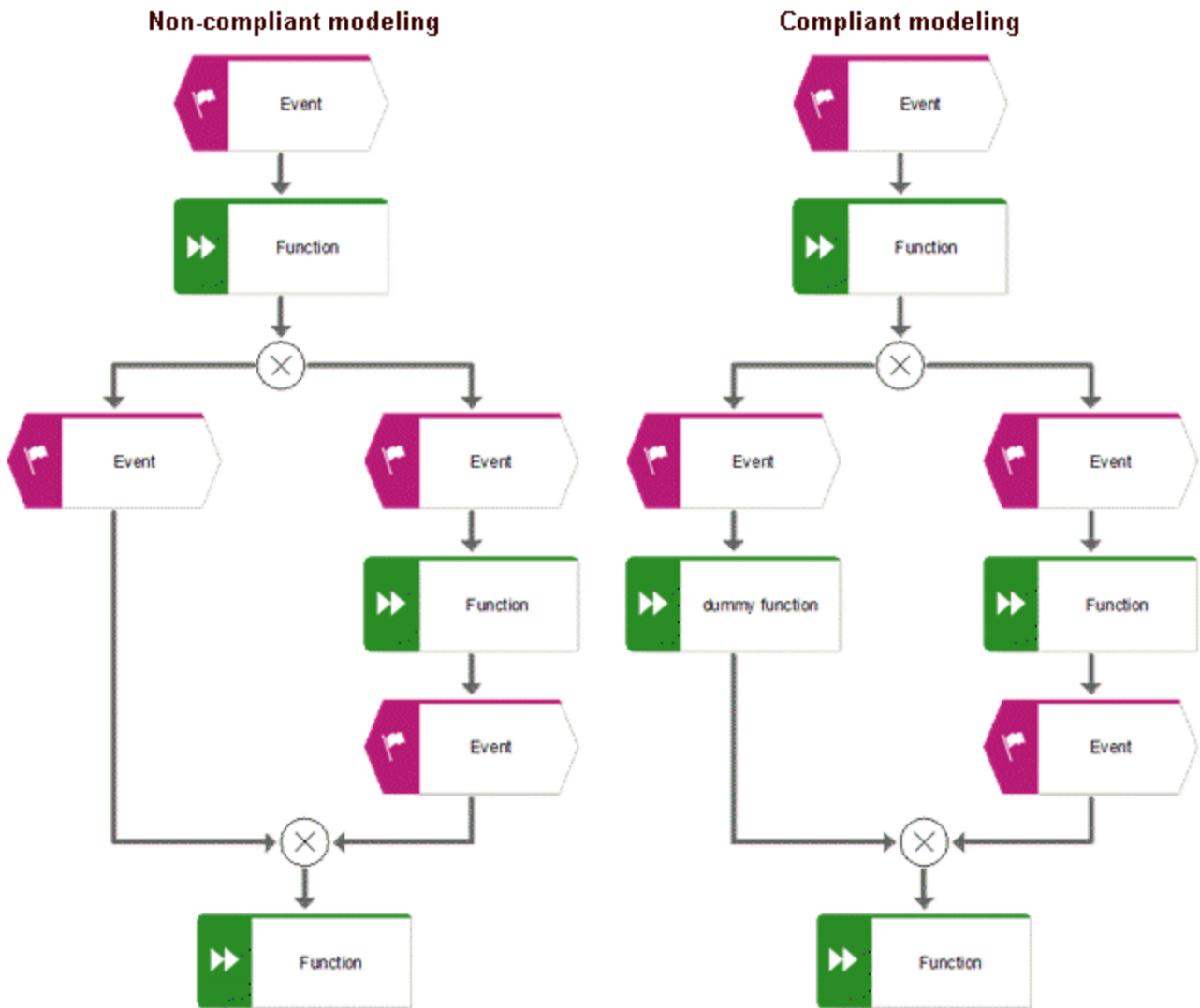



### 3 Automation data flows









The data flow of an executable process step in Process Governance is described using a **Data flow diagram**. It has exactly one superior object from the control flow. This means that for objects that have multiple object occurrences in a business model, each of these object occurrences has its own data flow diagram.





This chapter describes the input and output parameters of services used in Process Governance and the different types of operators, constants and variables.

The **System** user and the **arisservice** user must always have the **Process Governance administrator** function privilege to execute services. The function privilege controls the tasks that users can perform. The **system** user is created automatically. By default, the system user has all function privileges. The user **arisservice** is created automatically. By default, this user is assigned the **Database administrator** and **Process Governance administrator** function privileges.

### 3.1 Start context

This sign  stands for an incoming data flow, this sign  for an outgoing data flow.

In/Out	Name	Details	Data type
	Current database	Name of the database from which the process was started	<Text>
	Current server	Name of the ARIS Server on which the process was started.	<Text>
	Current tenant	Name of the ARIS tenant on which the process was started.	<Text>
	Current user	Login of the user who initiates the process. For example, this user can be assigned as a predefined user to an object of type <b>Human task</b> : The user starting the process is logged in to a modeling database. Please note that there may be situations in which the user is unknown, e.g., if the user is logged in anonymously or as a guest to an ARIS Publisher export, or if the process is started outside of ARIS from an intranet page. If you want to ensure that the initiator is known, add a field to the initial dialog into which the e-mail address of the user can be entered. You can then assign this field to an object of type <b>Human task</b> or to an object of type <b>Notification</b> (To, Cc, etc.) by using the operator <b>Determine user via e-mail/login name</b> .	<Text>
	Current filter	Name of the filter used for logging in to the database from which the process was started.	<Text>
	Current language	Language the user used for logging in to the database from which the process was started.	<Text>
	GUIDs of the selected items	Outputs the type names of items for which the process was started, e. g., Organizational chart or Function.	
	Types	Outputs the type names of items for which the process was started, e. g., Organizational chart or Function. This field may contain input data for an object of type <b>Automated task</b> or for a	<Text collection>

In/Output	Name	Details	Data type
		list in an object of type <b>Human task</b> .	
	Names of the selected items	Lists the names of items for which the process was started, e. g., models or objects.	
	Names	Lists all names of items for which the process was started, e. g., models or objects. This field may contain input data for an object of type <b>Automated task</b> or for a list in an object of type <b>Human task</b> .	<Text collection>
	Type names of the selected items	Outputs the type names of items for which the process was started, e. g., Organizational chart or Function.	
	Types	Outputs the type names of items for which the process was started, e. g., Organizational chart or Function. This field may contain input data for an object of type <b>Automated task</b> or for a list in an object of type <b>Human task</b> .	<Text collection>
	API names of the selected items	Outputs the API names of items for which the process was started, e. g., MT_ORG_CHRT for an organizational chart or OT_FUNC for a function.	
	API names	Outputs the API names of items for which the process was started, e. g., MT_ORG_CHRT for an organizational chart or OT_FUNC for a function. This field may contain input data for an object of type Automated task or for a list in an object of type Human task.	<Text collection>

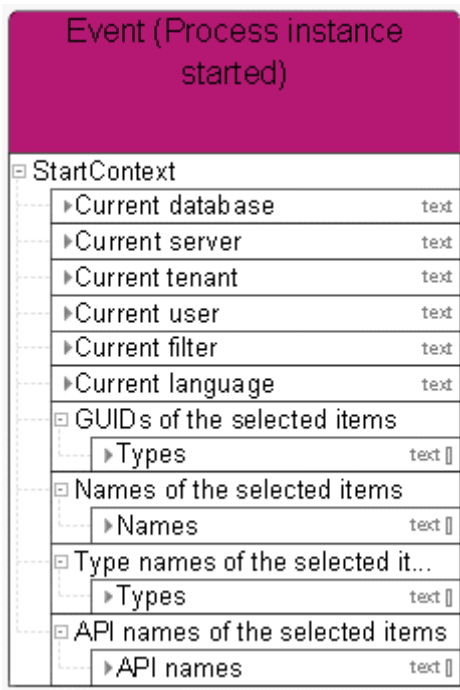







Figure 1: Start context



## 3.2 Human task

### 3.2.1 General data mapping

In/Out	Name	Details	Data type
	Task name	<p>This box shows the task name that the task is to be displayed with in ARIS Process Board. If an explicit name is not modeled in the data flow, the name of the associated object of the <b>Human task</b> type is displayed.</p> <p>The simple text structure required can be modeled as follows:</p> <p>For example, connect a constant with the value <b>Request from:</b> with an operator of the <b>Create collection</b> type and with an additional constant that represents the current date. Connect the <b>Create collection</b> operator with the <b>Task name</b> box via an operator of the <b>Format lines</b> type.</p>	<Text>
	Task description	<p>This field represents the description of the task with which the task is to be displayed in ARIS Process Board. If no explicit description is modeled in the data flow, nothing is displayed.</p>	<Text>



In/Out	Name	Details	Data type
	Group of executors (mandatory input)	<p>This field represents one or multiple person(s) who carry out the object of the type <b>Human task</b>. If an automation-relevant organizational element is connected with an object of type <b>Human task</b> via a connection of type <b>carries out</b>, a constant is automatically created. (Exception: The connection attribute is specified).</p> <p>The constant contains in its value the name of the organizational element and also complex XML information.</p> <p>If the input data is the XML structure that is transferred differently, the constant can be deleted. This is the case, for example, if:</p> <ul style="list-style-type: none"> <li>▪ a person selected while an object of the type <b>Human task</b> is being carried out can be connected as input data.</li> <li>▪ the login name can be connected as input data via the operator <b>Determine user via e-mail/login name</b>.</li> </ul> <p>Both options represent complex XML data.</p>	<User>
	Login of the predefined executor (optional)	<p>This field must be connected with the login of exactly one person from the group of executors. (If the person is not a member of this group, the assignment is ignored.)</p> <p>The simple text structure required can be modeled as follows:</p> <ul style="list-style-type: none"> <li>▪ Connect a text field of an object of type <b>Human task</b>, into which the login information was entered manually.</li> <li>▪ The current user of an initial dialog can be modeled as input data.</li> <li>▪ You can assign the Web service as input data, which extracts the login information from an ARIS attribute.</li> </ul>	<Text>
	Priority	<p>Each object of the type <b>Human task</b> has a priority. If no priority is specified, the priority <b>NORMAL</b> is applied. To define a priority as <b>HIGH</b> or <b>LOW</b>, connect a constant with the</p>	<Text>

In/O ut	Name	Details	Data type
		<p>corresponding value with this field. The value must be in upper case: LOW, NORMAL, HIGH.</p>	
	<p>Throughput time</p>	<p>This duration represents the time allowed for performing the task. (If this time is exceeded, an escalation e-mail is sent.)</p> <p>If the field is empty, the attribute <b>Maximum throughput time</b> of the object of the type <b>Human task</b> is used.</p> <p>If this field is connected with a duration, the time attribute is not effective.</p> <p>There are two ways to define a duration:</p> <ul style="list-style-type: none"> <li>▪ As input data, define a constant and connect it with the field, or connect an object of the type <b>Human task</b> for which the user has defined a duration.</li> <li>▪ With the second option, the duration that an object of the type <b>Human task</b> may have is dynamically defined during execution.</li> </ul>	<p>&lt;Duration&gt;</p>
	<p>Task-specific escalation</p>	<p>If a task is not performed in the predefined time, an escalation e-mail is sent to the person responsible. If this field is not connected, an e-mail is sent to the person who is organization manager for the executor of this object of the <b>Human task</b> type. If this field is connected with an escalation-relevant organization element, the e-mail is sent to this role.</p> <p>Example: the position <b>QM Manager</b> has to carry out an object of the <b>Human task</b> type. The escalation e-mail is sent to the process manager instead of the QM manager.</p>	<p>&lt;User&gt;</p>

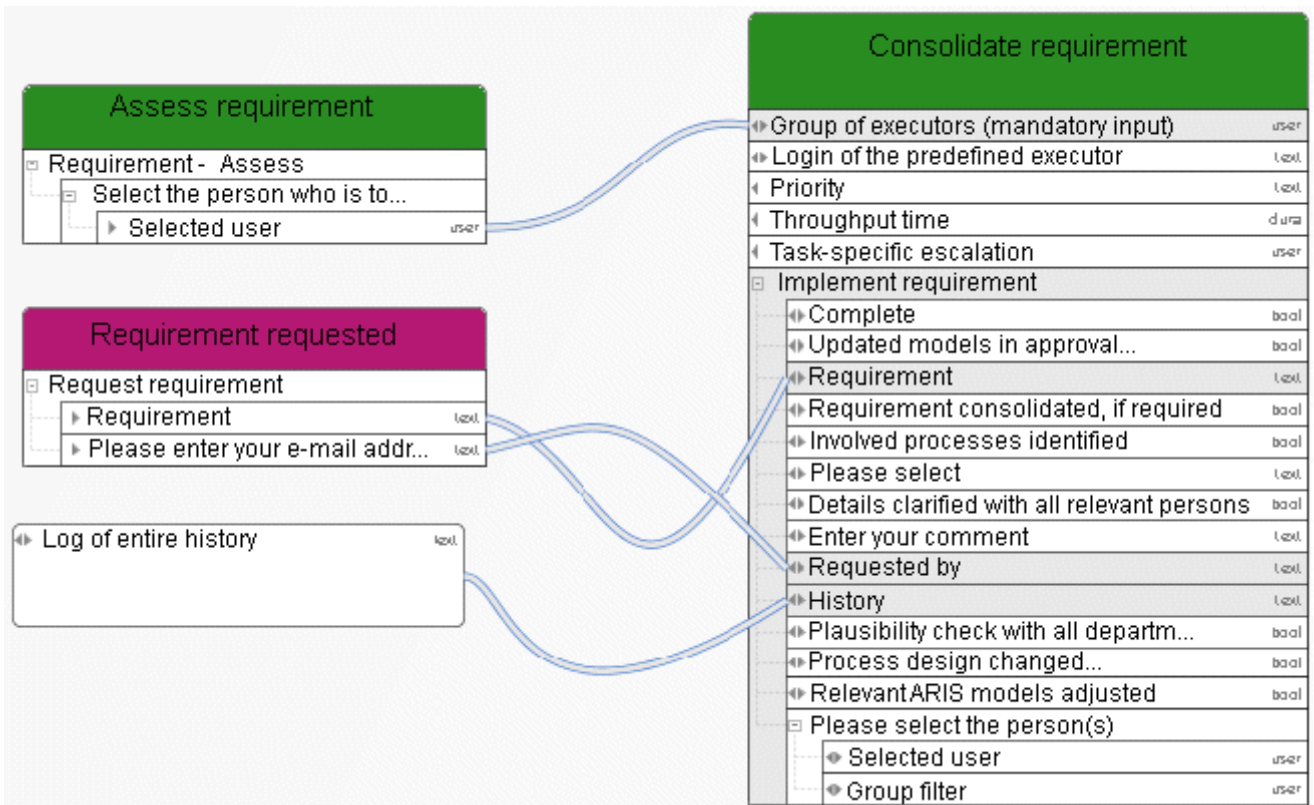

Figure 2: Task description

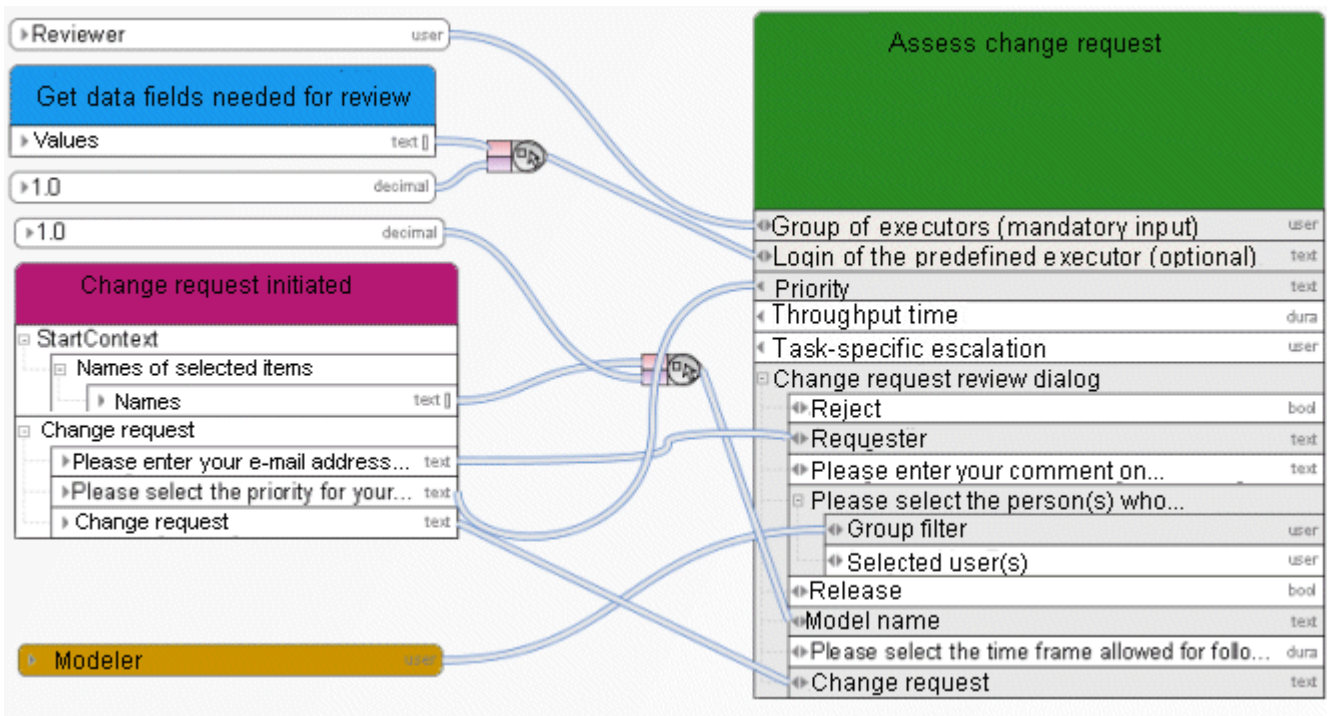

Figure 3: Example 1 – General data mapping - Login

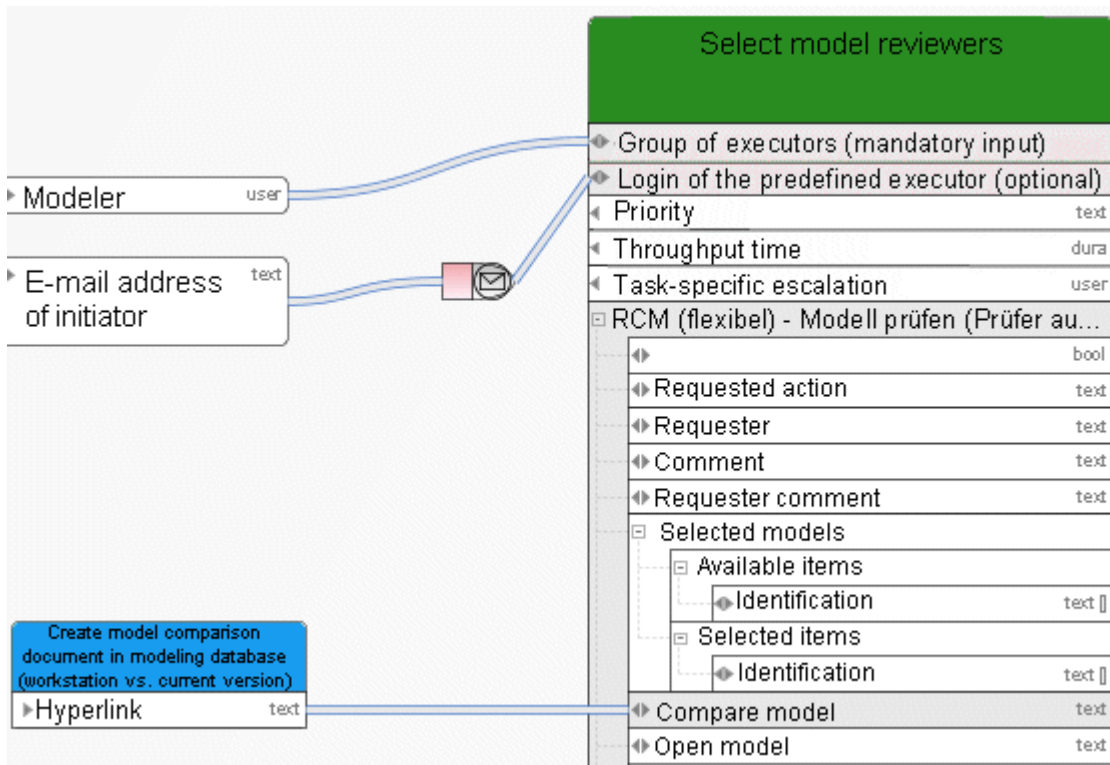



Figure 4: Example 2 – General data mapping - Login

### 3.2.2 Data mapping for user selection

In/O ut	Name	Details	Data type
	Selected user	If a selection of executors is offered in a dialog, these persons may have been preselected. (Input data from another object of the <b>Human task</b> type with user preselection) or they can be selected (output data of this object of the <b>Human task</b> type). If no input data are modeled, no preselection is displayed in the dialog. (The output data can be connected with the field <b>Group of executors</b> (mandatory input) of the object of the <b>Human task</b> type.)	<User>
	Group filter	If a selection of executors is used, the list of persons that the executor can select is defined by modeling an organizational element. If no organizational element is modeled, all persons with one of the following licenses are available: ARIS Connect Viewer, ARIS Connect Designer or ARIS Viewer.	<User>

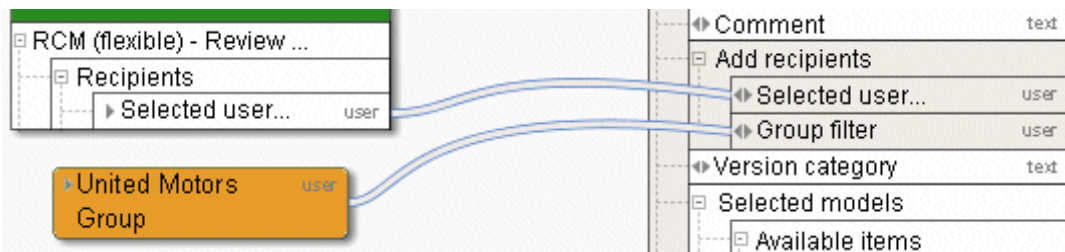

Figure 5: User selection

### 3.2.3 Data mapping for lists

In/O ut	Name	Details	Data type
	Available items	If a list is used in the dialog, values may be contained, e.g., a list of models.	
↻ ↻	Identification	To fill this list with values, either connect models or objects from the preselection of another object of type <b>Human task</b> , <b>Automated task</b> , or <b>Event (process instance started)</b> , or enter GUIDs and use the <b>Create collection</b> operator.	<Text collection>
	Selected items	If an editable list is used in the dialog, the executor can select items from the list, e.g., models.	
↻ ↻	Identification	The executor can select entries from a list. They can serve as input data for another object of type <b>Human task</b> or <b>Automated task</b> .	<Text collection>



Figure 6: Lists

### 3.3 Notification and live message

In/Out	Name	Details	Data type
→	To	Recipient of the notification. Only for notifications.	<User>
→	Cc	Copy, also a recipient of the notification. Only for notifications.	<User>
→	Bcc	Blind copy, also a recipient of the notification. Only for notifications.	<User>
→	Subject	Short description of the contents or topic.	<Text>
→	Contents	Contents of the notification or live message.	<Text>

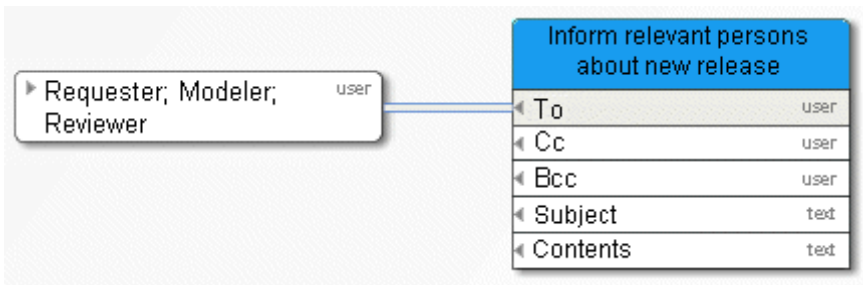

Figure 7: Example 1 – Notification

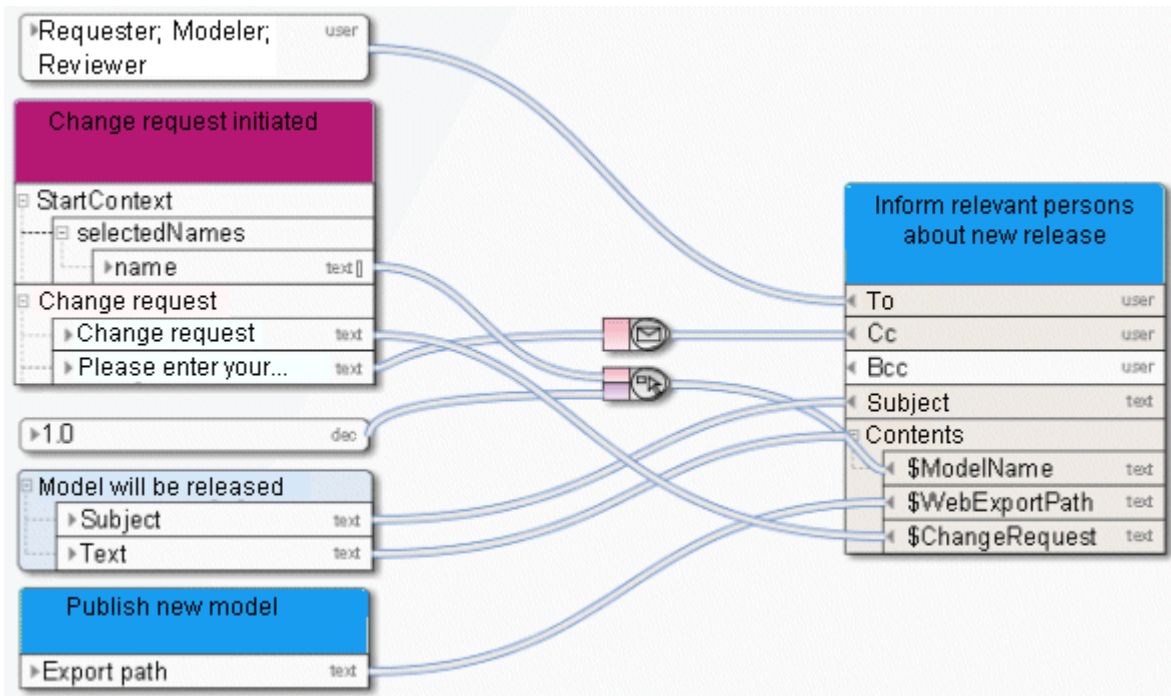

Figure 8: Example 2 – Notification

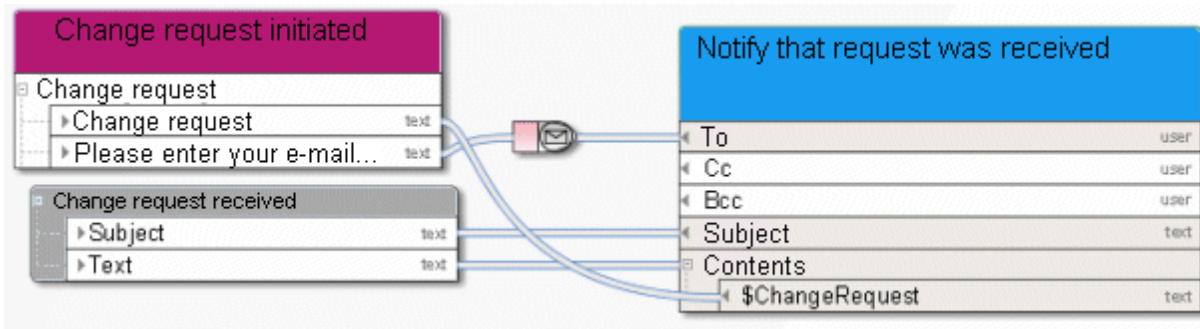









Figure 9: Live message



















## 3.4 ARIS Business services

### 3.4.1 Add - Models/Objects/Groups

This service merges models and/or objects of a source database into a target database.

In/Out	Name	Details	Data type
	Database name	Name of the database in which the function of type <b>Automated task</b> is carried out.	<Text>
	Database language	Language the service uses for logging in to the database, e.g., <b>en</b> for English. You can specify this in more detail, e. g., <b>en</b> for English or <b>en_US</b> for English (United States). This is helpful, for example, if English (Australia) has been set in the database, but standard English (USA) has not been set.  If you want to add the country, you need to create a language constant and model it as a language in the data flow.	<Text> or <Language>
	User login	Login name of the user that is used for carrying out the <b>Automated task</b> function. If no user is defined, <b>arisservice</b> is used.	<Text>
	Password	Password of the user that is used for carrying out the <b>Automated task</b> function.	<Password>
	Selected items	Select models, objects, or groups to be merged into the target database.	
	Identification	Either connect models, objects, or groups from the preselection of another object of type <b>Human task</b> , <b>Automated task</b> , or <b>Event (process instance started)</b> , or enter GUIDs and use the <b>Create collection</b> operator.	<Text collection>
	Target database	Either connect the target database from the preselection of another object of type <b>Human task</b> , <b>Automated task</b> , or <b>Event (process instance started)</b> , or enter the name of the target database using a constant.	<Text>
	Merge attributes	Define the Boolean constant as TRUE to merge the source and target attributes. Otherwise: FALSE. If no specification is made, the default	<Boolean>

In/O ut	Name	Details	Data type
		value FALSE is used.	
	Assignment level	Use a constant to specify the assignment level up to which assignments are included in the merge process.	<Decimal>
	Assignment outside the selection	Define how assignments are to be included in the merge process: Define the Boolean constant as TRUE to include border items. Otherwise: FALSE. If no specification is made, the default value FALSE is used.	<Boolean>
	Connection outside the selection	Define how connections are to be included in the merge process: Define the Boolean constant as TRUE to include border items. Otherwise: FALSE. If no specification is made, the default value FALSE is used.	<Boolean>
	Models: Source overwrites target	Define the settings to be used in the event of a conflict: Define the Boolean constant as TRUE to have items of the source database overwrite items of the target database. Otherwise: FALSE. If no specification is made, the default value FALSE is used.	<Boolean>
	Objects: Source overwrites target	Define the settings to be used in the event of a conflict: Define the Boolean constant as TRUE to have items of the source database overwrite items of the target database. Otherwise: FALSE. If no specification is made, the default value FALSE is used.	<Boolean>
	Connections: Source overwrites target	Define the settings to be used in the event of a conflict: Define the Boolean constant as TRUE to have items of the source database overwrite items of the target database. Otherwise: FALSE. If no specification is made, the default value FALSE is used.	<Boolean>
	Fonts: Source overwrites target	Define the settings to be used in the event of a conflict: Define the Boolean constant as TRUE to have items of the source database overwrite items of the target database. Otherwise: FALSE. If no specification is made, the default value FALSE is used.	<Boolean>

In/O ut	Name	Details	Data type
	Users: Source overwrites target	Define the settings to be used in the event of a conflict: Define the Boolean constant as TRUE to have items of the source database overwrite items of the target database. Otherwise: FALSE. If no specification is made, the default value FALSE is used.	<Boolean>
	User groups: Source overwrites target	Define the settings to be used in the event of a conflict: Define the Boolean constant as TRUE to have items of the source database overwrite items of the target database. Otherwise: FALSE. If no specification is made, the default value FALSE is used.	<Boolean>
	Merge users	Define the Boolean constant as TRUE to merge associated user groups. Otherwise: FALSE. If no specification is made, the default value FALSE is used.	<Boolean>
	Group: Include source	Define the Boolean constant as TRUE to select the group containing the source in the event of a conflict. Otherwise: FALSE. If no specification is made, the default value FALSE is used.	<Boolean>
	Synchronize assignments	Define the Boolean constant as TRUE to synchronize assignments. If relationships to a model did exist in the source database and if, during a merge, this model is found in the target database (e. g., from a previous merge), these relationships are created again.	<Boolean>
	Path	Path where the log file is to be saved.	<Text>
	Content root	Specify the part of the path to the content root, e.g., http://system123.me.corp.example.com:0909.	<Text>
	Error	If automation errors occur, context-specific error messages are displayed indicating, e.g., that ARIS Server is not available.	<Text>
	Result	Returns either TRUE or FALSE (Boolean), depending on whether or not the service was successfully performed.	<Boolean>

In/O ut	Name	Details	Data type
	Hyperlink	The hyperlink to the generated log file is output.	<Text>

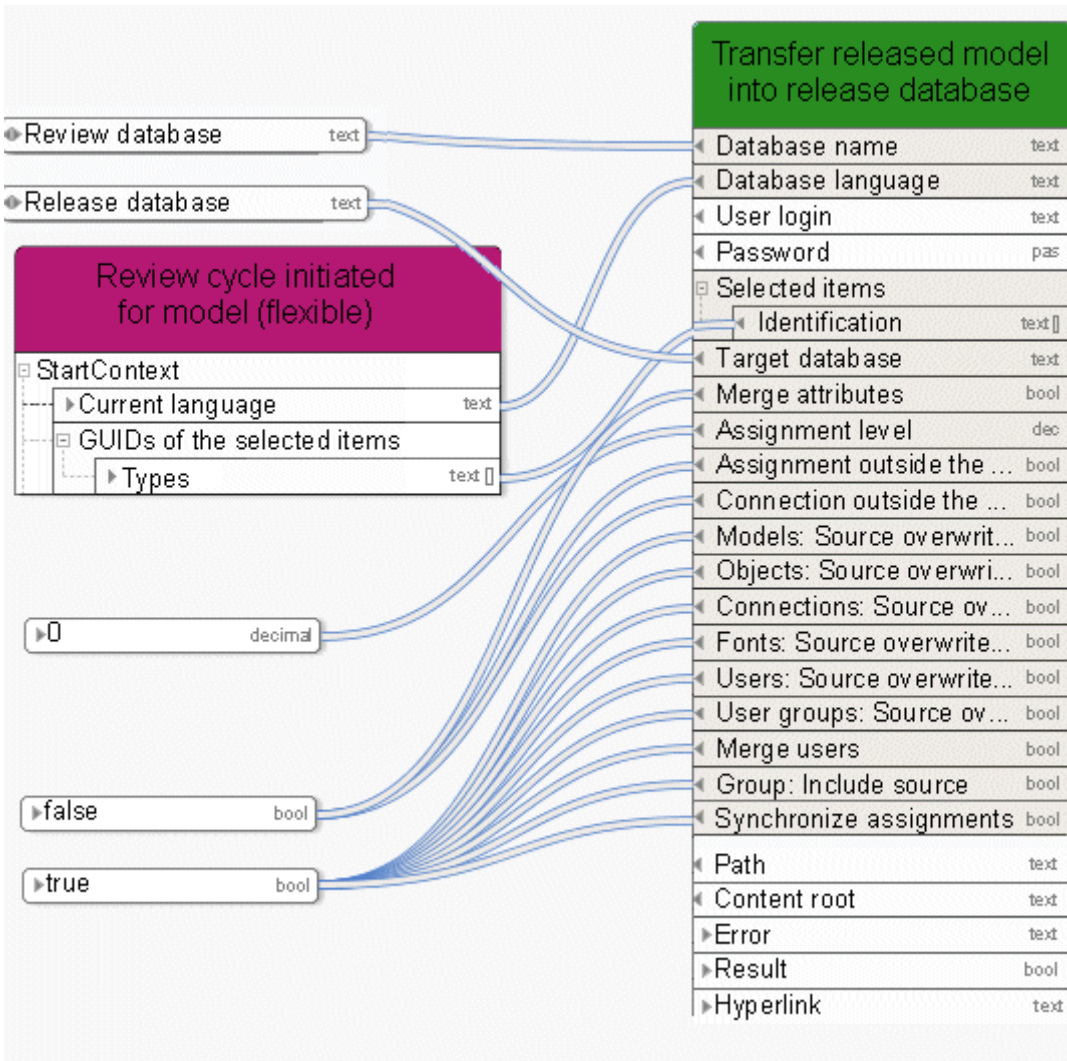



























Figure 10: Merge models/objects/groups



### 3.4.2 Compare - Model versions

This service compares two versions of one single model.

In/Output	Name	Details	Data type
	Database name	Name of the database in which the function of type <b>Automated task</b> is carried out.	<Text>
	Database language	Language the service uses for logging in to the database, e.g., <b>en</b> for English. You can specify this in more detail, e. g., <b>en</b> for English or <b>en_US</b> for English (United States). This is helpful, for example, if English (Australia) has been set in the database, but standard English (USA) has not been set.  If you want to add the country, you need to create a language constant and model it as a language in the data flow.	<Text> or <Language>
	User login	Login name of the user that is used for carrying out the <b>Automated task</b> function. If no user is defined, <b>arisservice</b> is used.	<Text>
	Password	Password of the user that is used for carrying out the <b>Automated task</b> function.	<Password>
	Selected models	Specifies the model whose versions are to be compared.	
	Model GUID	GUID of the model whose versions are to be compared.	<Text>
	Change list	Change list number of the latest version of the model.	<Decimal>
	Compare model properties	If the input is <b>TRUE</b> , the service compares whether the model properties of the versions to be compared differ. If the input is <b>FALSE</b> , this will not be compared.	<Boolean>
	Compare items that exist only in the source model	If the input is <b>TRUE</b> , the service compares whether the items that exist only in the source model differ in the versions to be compared. If the input is <b>FALSE</b> , this will not be compared.	<Boolean>

In/Out	Name	Details	Data type
	Compare items that exist only in the target model	If the input is <b>TRUE</b> , the service compares whether the items that exist only in the target model differ in the versions to be compared. If the input is <b>FALSE</b> , this will not be compared.	<Boolean>
	Compare items from both models	If the input is <b>TRUE</b> , the service compares whether the items that exist in the source and target model differ in the versions to be compared. If the input is <b>FALSE</b> , this will not be compared.	<Boolean>
	Compare object definitions	If the input is <b>TRUE</b> , the service compares whether the object definitions of the versions to be compared differ. If the input is <b>FALSE</b> , this will not be compared.	<Boolean>
	Compare object occurrences	If the input is <b>TRUE</b> , the service compares whether the object occurrences of the versions to be compared differ. If the input is <b>FALSE</b> , this will not be compared.	<Boolean>
	Compare object occurrences: Appearance	If the input is <b>TRUE</b> , the service compares whether the appearance of the object occurrences of the versions to be compared differ. If the input is <b>FALSE</b> , this will not be compared.	<Boolean>
	Compare object occurrences: Position/Size	If the input is <b>TRUE</b> , the service compares whether the position and/or size of the object occurrences of the versions to be compared differ. If the input is <b>FALSE</b> , this will not be compared.	<Boolean>
	Compare object occurrences: Attribute placement	If the input is <b>TRUE</b> , the service compares whether the attribute placements of the object occurrences of the versions to be compared differ. If the input is <b>FALSE</b> , this will not be compared.	<Boolean>
	Compare connection definitions	If the input is <b>TRUE</b> , the service compares whether the connection definitions of the versions to be compared differ. If the input is <b>FALSE</b> , this will not be compared.	<Boolean>

In/O ut	Name	Details	Data type
	Compare connection occurrences	If the input is <b>TRUE</b> , the service compares whether the connection occurrences of the versions to be compared differ. If the input is <b>FALSE</b> , this will not be compared.	<Boolean>
	Connection appearance	If the input is <b>TRUE</b> , the service compares whether the connection appearance of the versions to be compared differs. If the input is <b>FALSE</b> , this will not be compared.	<Boolean>
	Inflection points	If the input is <b>TRUE</b> , the service compares whether the inflection points of the versions to be compared differ. If the input is <b>FALSE</b> , this will not be compared.	<Boolean>
	Connection attribute placement	If the input is <b>TRUE</b> , the service compares whether the connection attribute placements of the versions to be compared differ. If the input is <b>FALSE</b> , this will not be compared.	<Boolean>
	Compare graphic objects	If the input is <b>TRUE</b> , the service compares whether the graphic objects of the versions to be compared differ. If the input is <b>FALSE</b> , this will not be compared.	<Boolean>
	Compare OLE objects	If the input is <b>TRUE</b> , the service compares whether the OLE objects of the versions to be compared differ. If the input is <b>FALSE</b> , this will not be compared.	<Boolean>
	Compare free-form texts	If the input is <b>TRUE</b> , the service compares whether the free-form texts of the versions to be compared differ. If the input is <b>FALSE</b> , this will not be compared.	<Boolean>
	Path	If the input is <b>TRUE</b> , the service compares whether the paths of the versions to be compared differ. If the input is <b>FALSE</b> , this will not be compared.	<Boolean>
	Content root	If the input is <b>TRUE</b> , the service compares whether the content roots of the versions to be compared differ. If the input is <b>FALSE</b> , this will not be compared.	<Boolean>

In/Out	Name	Details	Data type
	Error	If automation errors occur, context-specific error messages are displayed indicating, e.g., that ARIS Server is not available.	<Text>
	Result	Returns either TRUE or FALSE (Boolean), depending on whether or not the service was successfully performed. If no specification is made, the default value FALSE is used.	<Boolean>
	Hyperlink	Hyperlink to the result of the model version comparison.	<Text>



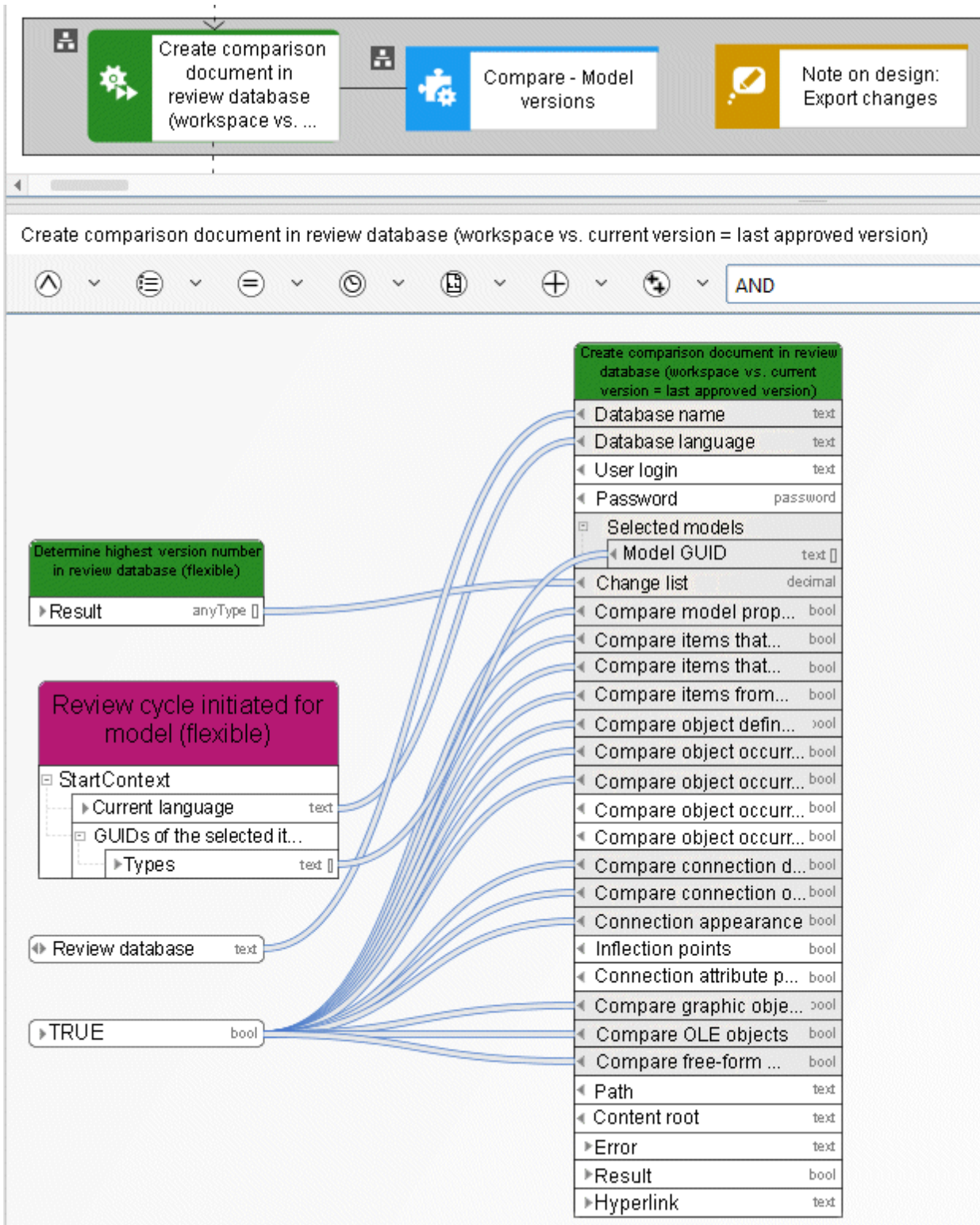









Figure 11: Compare - Model versions

### 3.4.3 Copy - Database

This service copies an existing database and renames the new database as required.

In/Out	Name	Details	Data type
	Database name	Name of the database in which the function of type <b>Automated task</b> is carried out.	<Text>
	Database language	Language the service uses for logging in to the database, e.g., <b>en</b> for English. You can specify this in more detail, e. g., <b>en</b> for English or <b>en_US</b> for English (United States). This is helpful, for example, if English (Australia) has been set in the database, but standard English (USA) has not been set.  If you want to add the country, you need to create a language constant and model it as a language in the data flow.	<Text> or <Language>
	User login	Login name of the user that is used for carrying out the <b>Automated task</b> function. If no user is defined, <b>arisservice</b> is used.	<Text>
	Password	Password of the user that is used for carrying out the <b>Automated task</b> function.	<Password>
	Name of the new database	The new database is created with this name.	<Text>
	Error	If automation errors occur, context-specific error messages are displayed indicating, e.g., that ARIS Server is not available.	<Text>
	Result	Returns either TRUE or FALSE (Boolean), depending on whether or not the service was successfully performed. If no specification is made, the default value FALSE is used.	<Boolean>

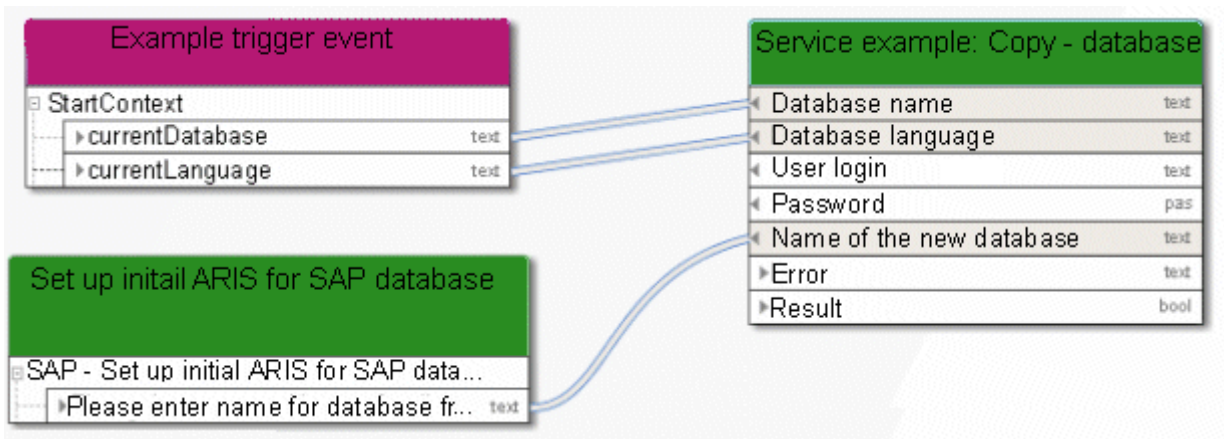











Figure 12: Copy database

### 3.4.4 Create - 1 directory/group

This service creates exactly one group.

In/Out	Name	Details	Data type
	Database name	Name of the database in which the function of type <b>Automated task</b> is carried out.	<Text>
	Database language	Language the service uses for logging in to the database, e.g., <b>en</b> for English. You can specify this in more detail, e. g., <b>en</b> for English or <b>en_US</b> for English (United States). This is helpful, for example, if English (Australia) has been set in the database, but standard English (USA) has not been set.  If you want to add the country, you need to create a language constant and model it as a language in the data flow.	<Text> or <Language>
	User login	Login name of the user that is used for carrying out the <b>Automated task</b> function. If no user is defined, <b>arisservice</b> is used.	<Text>
	Password	Password of the user that is used for carrying out the <b>Automated task</b> function.	<Password>
	Path	Enter the path in which you want to save the new group (e. g., Main group\Processes\Sales processes) in the relevant database using the correct database language.	<Text>
	Group name	Enter the name of the new group, e. g.: <b>Processes</b> .	<Text>
	Error	If automation errors occur, context-specific error messages are displayed indicating, e.g., that ARIS Server is not available.	<Text>
	Result	Returns either TRUE or FALSE (Boolean), depending on whether or not the service was successfully performed.	<Boolean>
	Created path	The path to the created group.	<Text>
	Group GUID	GUID of the created group.	<Text>

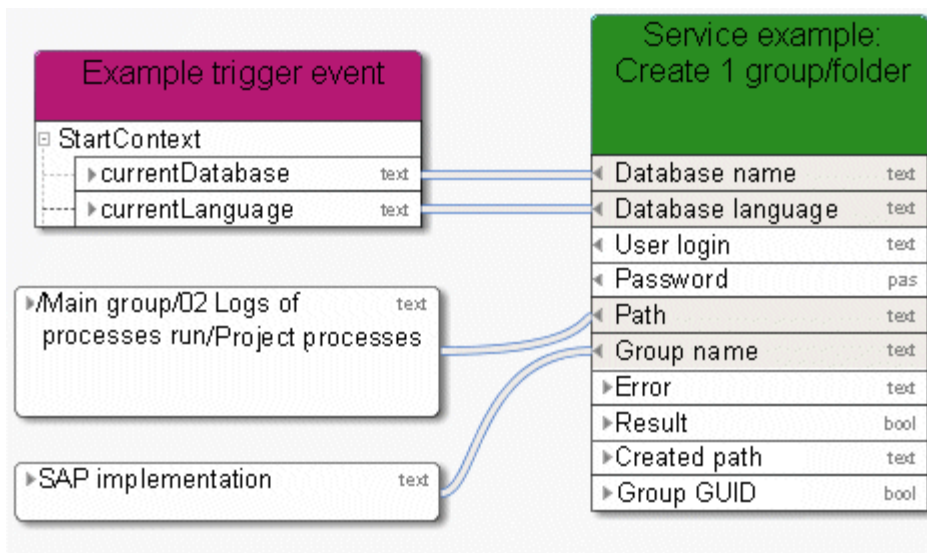











Figure 13: Create exactly one group/directory

### 3.4.5 Create - 1 model

This service creates exactly one model of any required type.

In/Out	Name	Details	Data type
	Database name	Name of the database in which the function of type <b>Automated task</b> is carried out.	<Text>
	Database language	Language the service uses for logging in to the database, e.g., <b>en</b> for English. You can specify this in more detail, e. g., <b>en</b> for English or <b>en_US</b> for English (United States). This is helpful, for example, if English (Australia) has been set in the database, but standard English (USA) has not been set.  If you want to add the country, you need to create a language constant and model it as a language in the data flow.	<Text> or <Language>
	User login	Login name of the user that is used for carrying out the <b>Automated task</b> function. If no user is defined, <b>arisservice</b> is used.	<Text>
	Password	Password of the user that is used for carrying out the <b>Automated task</b> function.	<Password>
	Model name	Enter the name of the new model.	<Text>
	Model type	Define the model type using the API name, e. g.: MT_EPC for Event-driven process chain.	<Text>
	Path	Enter the path in which you want to save the new model (e. g., Main group\Processes\Sales processes) in the relevant database using the correct database language.	<Text>
	Error	If automation errors occur, context-specific error messages are displayed indicating, e.g., that ARIS Server is not available.	<Text>
	Result	Returns either TRUE or FALSE (Boolean), depending on whether or not the service was successfully performed.	<Boolean>
	Model GUID	Returns the GUID of the newly created model.	<Text>

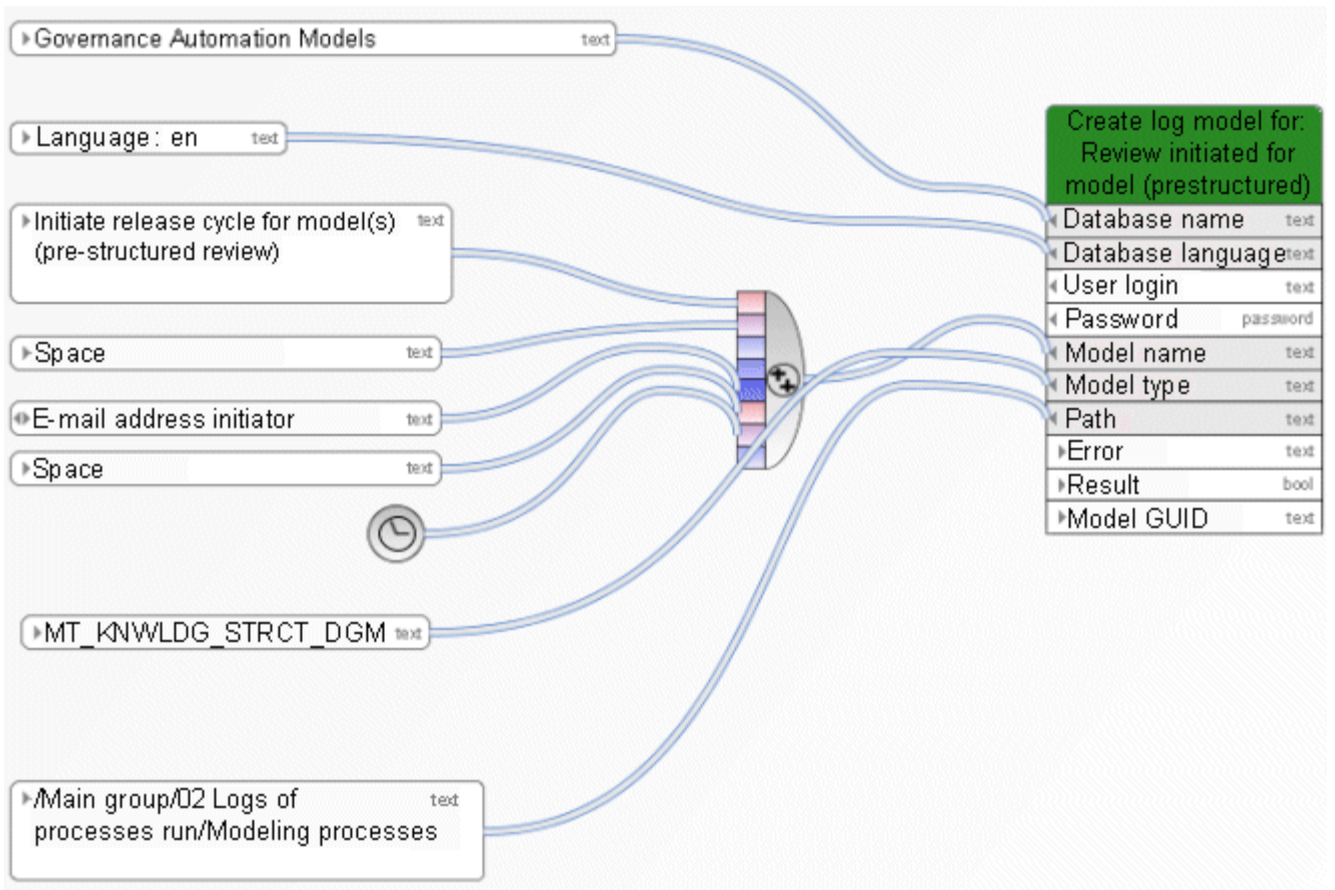













Figure 14: Create exactly one model





### 3.4.6 Create - 1 object

This service creates exactly one object of any required type. You can also create connections to existing objects and assignments for existing models.

In/Output	Name	Details	Data type
	Database name	Name of the database in which the function of type <b>Automated task</b> is carried out.	<Text>
	Database language	Language the service uses for logging in to the database, e.g., <b>en</b> for English. You can specify this in more detail, e. g., <b>en</b> for English or <b>en_US</b> for English (United States). This is helpful, for example, if English (Australia) has been set in the database, but standard English (USA) has not been set.  If you want to add the country, you need to create a language constant and model it as a language in the data flow.	<Text> or <Language>
	User login	Login name of the user that is used for carrying out the <b>Automated task</b> function. If no user is defined, <b>arisservice</b> is used.	<Text>
	Password	Password of the user that is used for carrying out the <b>Automated task</b> function.	<Password>
	Object name	Enter the name for the new object.	<Text>
	Object type	Define the object type by using the API name, e.g.: OT_FUNC for function.	<Text>
	Occurrence in model	Specify in which models the new object will have occurrences.	
	Identification	Either connect models, objects, or groups from the preselection of another object of type <b>Human task, Automated task, or Event (process instance started)</b> , or enter GUIDs and use the <b>Create collection</b> operator.	<Text collection>
	Occurrence symbol	Specify which symbol should be used to display the new object. To do so, use the API name. Example: ST_PRCS_IF for <b>Process interface</b> . If no symbol is defined or if the symbol is not	<Text>



In/Output	Name	Details	Data type
		allowed in the model type, the default symbol is used.	
	Model assignment	Existing models can be assigned to the object.	
	Identification	Specify which models are to be assigned. To do this, either connect models from the preselection of another object of type <b>Human task, Automated task, or Event (process instance started)</b> , or enter GUIDs and use the <b>Create collection</b> operator.	<Text collection>
	Source object	You can define connections to existing source objects.	
	Identification	Define source objects for which connections are created. To do this, either connect models from the preselection of another object of type <b>Human task, Automated task, or Event (process instance started)</b> , or enter GUIDs and use the <b>Create collection</b> operator.	<Text collection>
	Connection types of incoming connections	Define types for the connections that are created to run from existing objects to this new object.	
	Type	Define connection types by using the <b>Create collection</b> operator and the API name, e.g.: CT_IS_INP_FOR for <b>Is input for</b> . If you have defined multiple source objects using the <b>Create collection</b> operator, you may specify multiple connection types. In this case, the order is determined by which connections are created to which object (first source object is assigned to the first connection type, etc.).	<Text collection>
	Target objects	Define connections for existing objects.	
	Identification	Define target objects for which connections are created. To do this, either connect models from the preselection of another object of type <b>Human task, Automated task, or Event (process instance started)</b> , or enter GUIDs and use the <b>Create collection</b> operator.	<Text collection>

In/O ut	Name	Details	Data type
	Connection types of outgoing connections	Define types for the connections that are created to run from the new object to existing objects.	
	Type	Define connection types by using the <b>Create collection</b> operator and the API name, e.g.: CT_HAS_OUT for <b>has as output</b> . If you have defined multiple target objects using the <b>Create collection</b> operator, you may specify multiple connection types. In this case, the order is determined by which connections are created to which object (first target object is assigned to the first connection type, etc.).	<Text collection>
	Path	Enter the path in which you want to save the new group (e. g., Main group\Processes\Sales processes) in the relevant database using the correct database language.	<Text>
	Error	If automation errors occur, context-specific error messages are displayed indicating, e.g., that ARIS Server is not available.	<Text>
	Result	Returns either TRUE or FALSE (Boolean), depending on whether or not the service was successfully performed.	<Boolean>
	Object GUID	Returns the GUID of the newly created object.	<Text>

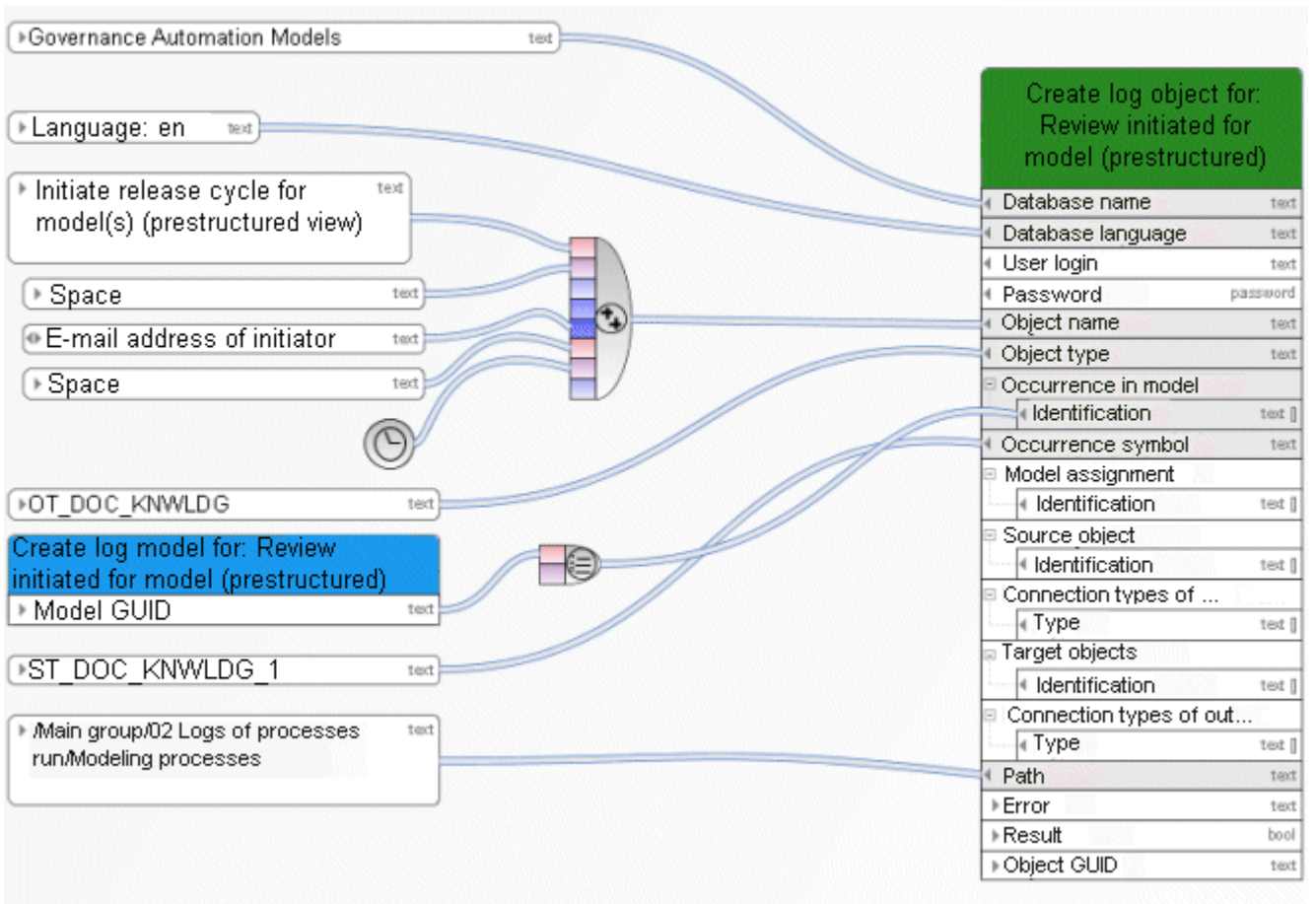











Figure 15: Create exactly one object

### 3.4.7 Create - Database

This service creates a database. The name of the database is input data. If a database already exists with the same name, a number is attached to the name of the new database, e.g., **<Name>(1)**.

In/Output	Name	Details	Data type
	Database name	Name of the database in which the function of type <b>Automated task</b> is carried out.	<Text>
	Database language	Language the service uses for logging in to the database, e.g., <b>en</b> for English. You can specify this in more detail, e. g., <b>en</b> for English or <b>en_US</b> for English (United States). This is helpful, for example, if English (Australia) has been set in the database, but standard English (USA) has not been set.  If you want to add the country, you need to create a language constant and model it as a language in the data flow.	<Text> or <Language>
	User login	Login name of the user that is used for carrying out the <b>Automated task</b> function. If no user is defined, <b>arisservice</b> is used.	<Text>
	Password	Password of the user that is used for carrying out the <b>Automated task</b> function.	<Password>
	Skip if already available	If this is defined as <b>true</b> , the database is created only if there is not already a database with this name on the server.	<Boolean>
	Database name	The new database is created with this name. Special characters are not allowed. If the name contains special characters, an error message is displayed.	<Text>
	Is versionable	If the input is TRUE, the new database is created as a versionable database, if it is FALSE, the database is not versionable.	<Boolean>
	Error	If automation errors occur, context-specific error messages are displayed indicating, e.g., that ARIS Server is not available.	<Text>

In/Out	Name	Details	Data type
	Result	Returns either TRUE or FALSE (Boolean), depending on whether or not the service was successfully performed. If no specification is made, the default value FALSE is used.	<Boolean>

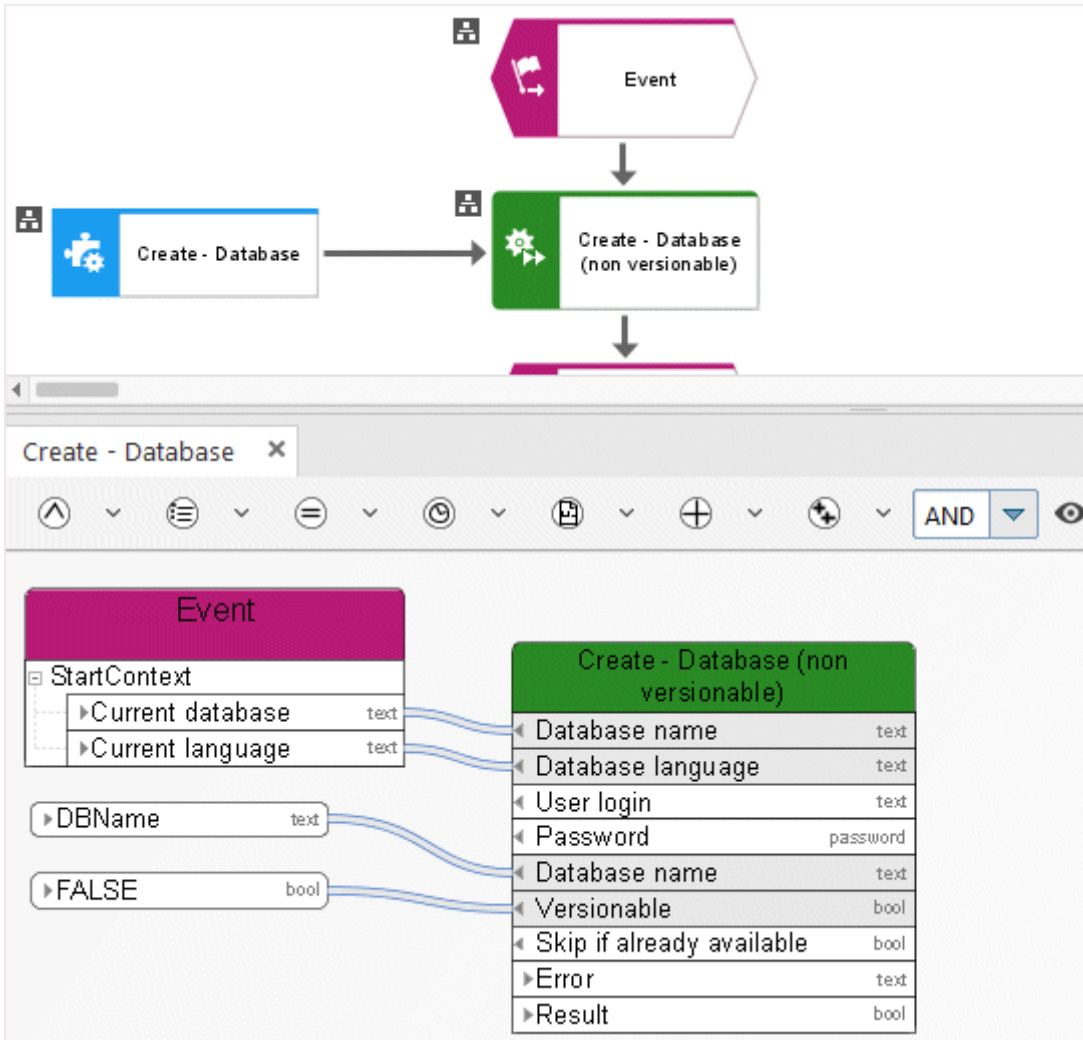































Figure 16: Create database

### 3.4.8 Create - Dynamic ARIS Publisher export

This service creates Web exports to provide other persons with specific models in read-only mode. The export is dynamic and thus takes into account access privileges, includes view generation, etc.

In/Out	Name	Details	Data type
	Database name	Name of the database in which the function of type <b>Automated task</b> is carried out.	<Text>
	Database language	Language the service uses for logging in to the database, e.g., <b>en</b> for English. You can specify this in more detail, e. g., <b>en</b> for English or <b>en_US</b> for English (United States). This is helpful, for example, if English (Australia) has been set in the database, but standard English (USA) has not been set.  If you want to add the country, you need to create a language constant and model it as a language in the data flow.	<Text> or <Language>
	User login	Login name of the user that is used for carrying out the <b>Automated task</b> function. If no user is defined, <b>arisservice</b> is used.	<Text>
	Password	Password of the user that is used for carrying out the <b>Automated task</b> function.	<Password>
	ARIS Publisher Server	Name of the ARIS Publisher Server on which the database is stored.	<Text>
	ARIS Publisher Server port	Port used by ARIS Publisher Server on which the database is stored.	<Decimal>
	Export name	Name that is displayed in the list when the export opens.	<Text>
	Export description	Description that is displayed in the list when the export opens.	<Text>
	Change list	Define the change list number to export versioned contents. Either connect an object of type <b>Automated task</b> (which, for example, generates a version and outputs the change list number), <b>Human task</b> , or <b>Event (process instance started)</b> (where the change list	<Decimal>

In/O ut	Name	Details	Data type
		number was entered). Or connect a constant with the change list number.	
	Referenced export	Is used to specify the name of the export the current export references in order to navigate from one export to the other (e. g., from the current export to an older version).	<Text>
	Template	Enter the GUID of the template (see properties) you want to apply when performing an export.	<Text>
	Export language	Export the database in multiple languages.	
	Languages	Specify the language code as follows: <b>en_US, en_US, en_US; de_DE, de_DE, de_DE.</b> (ISO 639 language codes are used.) For a single language, you can use a constant of the <b>Language</b> (page 202) type.	<Text collection>
	Default language ID	If the content is not specified in the selected language, enter the ID of the language to be used, for example: <b>1033</b> for English.	<Text>
	Profile name	Enter a name for the profile you want to use when performing exports.	<Text>
	Profile description	Enter a description for the profile you want to use when performing exports.	<Text>
	Path for copied documents	Specify the path to which you want to copy the linked documents.	<Boolean>
	Use print scale	Define the Boolean constant as TRUE to display models using the specified print scale, otherwise as FALSE. If no specification is made, the default value FALSE is used.	<Boolean>
	Initial scaling	Define initial scaling, e.g., 100.	<Decimal>
	Scaling	Define the scaling steps for your model, for example: 75,100,125,150.	<Text>
	Black and white	Define the Boolean constant as TRUE to display your model in black and white, otherwise as FALSE. If no specification is made, the default value FALSE is used.	<Boolean>

In/Out	Name	Details	Data type
	Transparent	Define the Boolean constant as TRUE to display your model as transparent, otherwise as FALSE. If no specification is made, the default value FALSE is used.	<Boolean>
	List of document links	Specify the link attributes for which you want to copy documents.	
	Attribute type	Define link attribute types using the API name, e.g., AT_EXT_1 for Link 1, or enter GUIDs and use the <b>Create collection</b> operator.	<Text collection>
	Layout	Select the layout for the ARIS Publisher output, e.g., <b>defaultLayout</b> .	
	User name	Please enter a default login name so that the generated export opens automatically when a hyperlink is clicked in a dialog. If you do not enter a login name here, users must enter their login name when opening the export via a hyperlink.	<Text>
	Password	Please enter the password for the login name so that the generated export opens automatically when a hyperlink is clicked in a dialog. If you do not enter a password here, users must enter their password when opening the export via a hyperlink.	<Text>
	Anonymous	Define the Boolean constant as TRUE to make the export accessible to anyone, otherwise as FALSE. If no specification is made, the default value FALSE is used.	<Boolean>
	Error	If automation errors occur, context-specific error messages are displayed indicating, e.g., that ARIS Server is not available.	<Text>
	Result	Returns either TRUE or FALSE (Boolean), depending on whether or not the service was successfully performed.	<Boolean>
	Export path	The path where the export result is stored. This can be used as a hyperlink.	<Text>



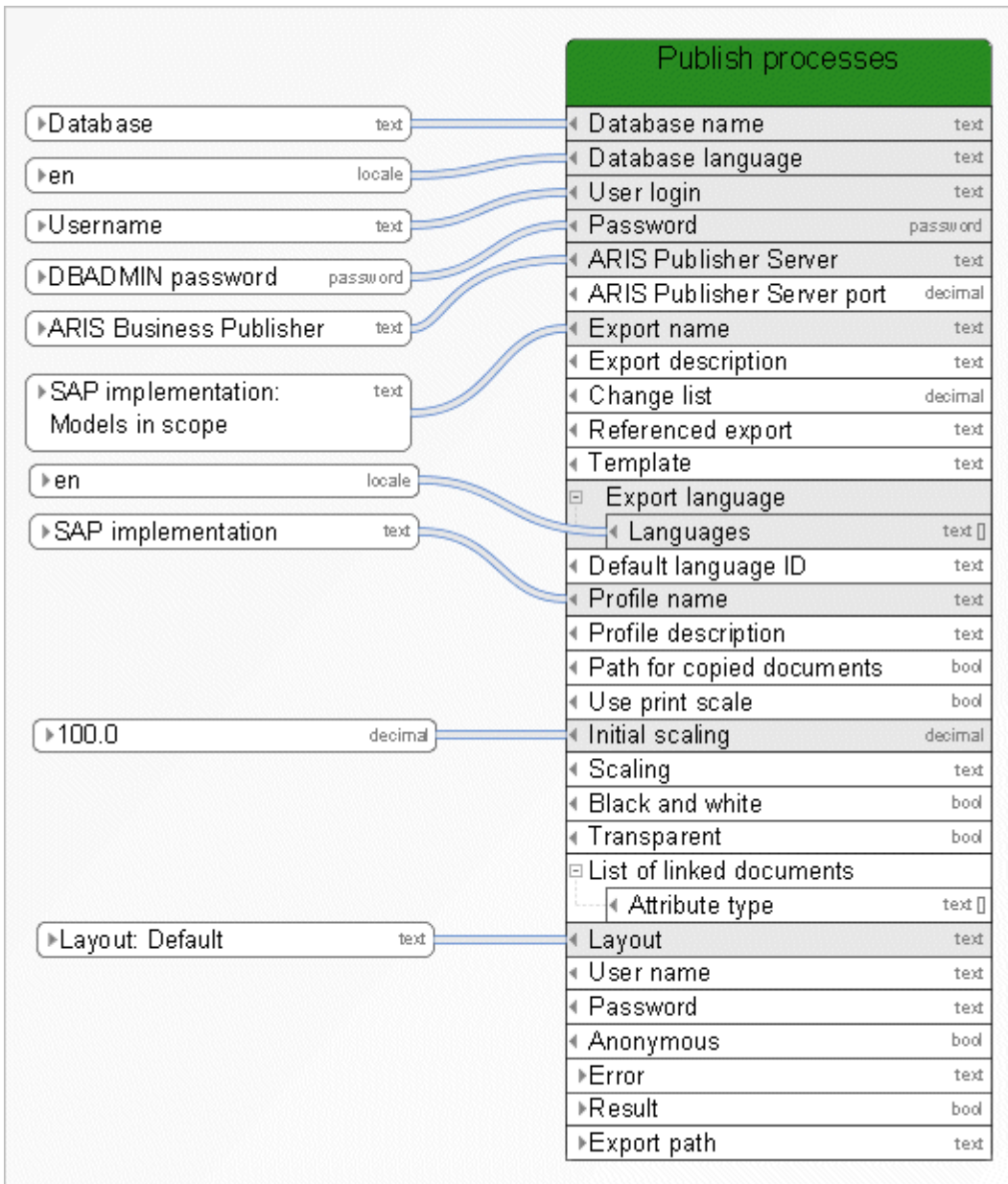



















Figure 17: Create dynamic ARIS Publisher export

### 3.4.9 Create - Report

This service starts reports. If the report requires user-defined settings, please specify them. For settings to be defined in the data flow, the report script must be allowed to start automatically. This may require report script changes. The report results are saved in ARIS document storage.

In/Out	Name	Details	Data type
	Database name	Name of the database in which the function of type <b>Automated task</b> is carried out.	<Text>
	Database language	Language the service uses for logging in to the database, e.g., <b>en</b> for English. You can specify this in more detail, e. g., <b>en</b> for English or <b>en_US</b> for English (United States). This is helpful, for example, if English (Australia) has been set in the database, but standard English (USA) has not been set.  If you want to add the country, you need to create a language constant and model it as a language in the data flow.	<Text> or <Language>
	User login	Login name of the user that is used for carrying out the <b>Automated task</b> function. If no user is defined, <b>arisservice</b> is used.	<Text>
	Password	Password of the user that is used for carrying out the <b>Automated task</b> function.	<Password>
	Script ID	Enter the ID of the script you want to run (see properties).	<Text>
	Selected items	Start scripts for different contexts, such as database, model, object, or group.	
	Identification	Either connect models, objects, or groups from the preselection of another object of type <b>Human task</b> , <b>Automated task</b> , or <b>Event (process instance started)</b> , or enter GUIDs and use the <b>Create collection</b> operator. The database is always the one defined in the above field (database name).	<Text collection>
	Method filter GUID	Enter the GUID of the method filter (see properties) you want to use when running the script.	<Text>

In/O ut	Name	Details	Data type
	Evaluation filter GUID	Enter the GUID of the evaluation filter (see properties) you want to use when running the script.	<Text>
	Script language	Use the script to output a predefined text, e. g., for the term <b>table of contents</b> . Specify the language in which you want to output the text. (ISO 639 language codes are used, e. g., 'en' for English.) If you have not specified a language or the language you have specified is not available, the first language found is used.	<Text>
	Output format	Enter the output format you want to create, e. g., doc, xls, or pdf. (RTF = 0, TEXT = 2, HTML = 3, MS WORD = 4, MS EXCEL = 5, OTHER = 7, XML = 8, PDF = 9, DOCX = 11, ODT = 13, XLSX = 14, no output = -1, scriptrunner.outputformat=-1)	<Decimal>
	Content root	Specify the path to the content root, e.g., <a href="http://system123.me.corp.example.com:0909">http://system123.me.corp.example.com:0909</a> .	<Text>
	User property names	To run a report, you need to enter the input parameters. Please note: For settings to be defined, the report script must be allowed to start automatically. This may require report script changes.	
	User input values	To run a report, you need to enter the input parameters. Please note: For settings to be defined, the report script must be allowed to start automatically. This may require report script changes.	
	Type	Please enter the corresponding values that are defined in the source code of the report. Please note: For settings to be defined, the report script must be allowed to start automatically. This may require report script changes.	<Text collection>
	Error	If automation errors occur, context-specific error messages are displayed indicating, e.g., that ARIS Server is not available.	<Text>
	Result	Returns either TRUE or FALSE (Boolean), depending on whether or not the service was	<Boolean>

In/O ut	Name	Details	Data type
		successfully performed.	
	Output path	Path to the document created, e.g. link to the document created in ARIS document storage.	<Text>
	Output data	Depending on how the report script was programmed, it may be necessary that it passes on data. If you define data here, you can use this output data as input data for an object of type <b>Human task</b> or <b>Automated task</b> or for an object of type <b>Notification</b> .	
	Data combinations	Data consists of a data key and a data value. The first data key has the first data value, and so on.	
	Key	Please enter the valid data keys defined in the report's source code as constants. To do so, use the <b>Create collection</b> operator.	<Text>
	Value	For every valid data key enter the data value that is to be used as the output. To do so, use the <b>Create collection</b> operator. Please note that key and value must match: the first data key has the first data value, and so on.	<Text>

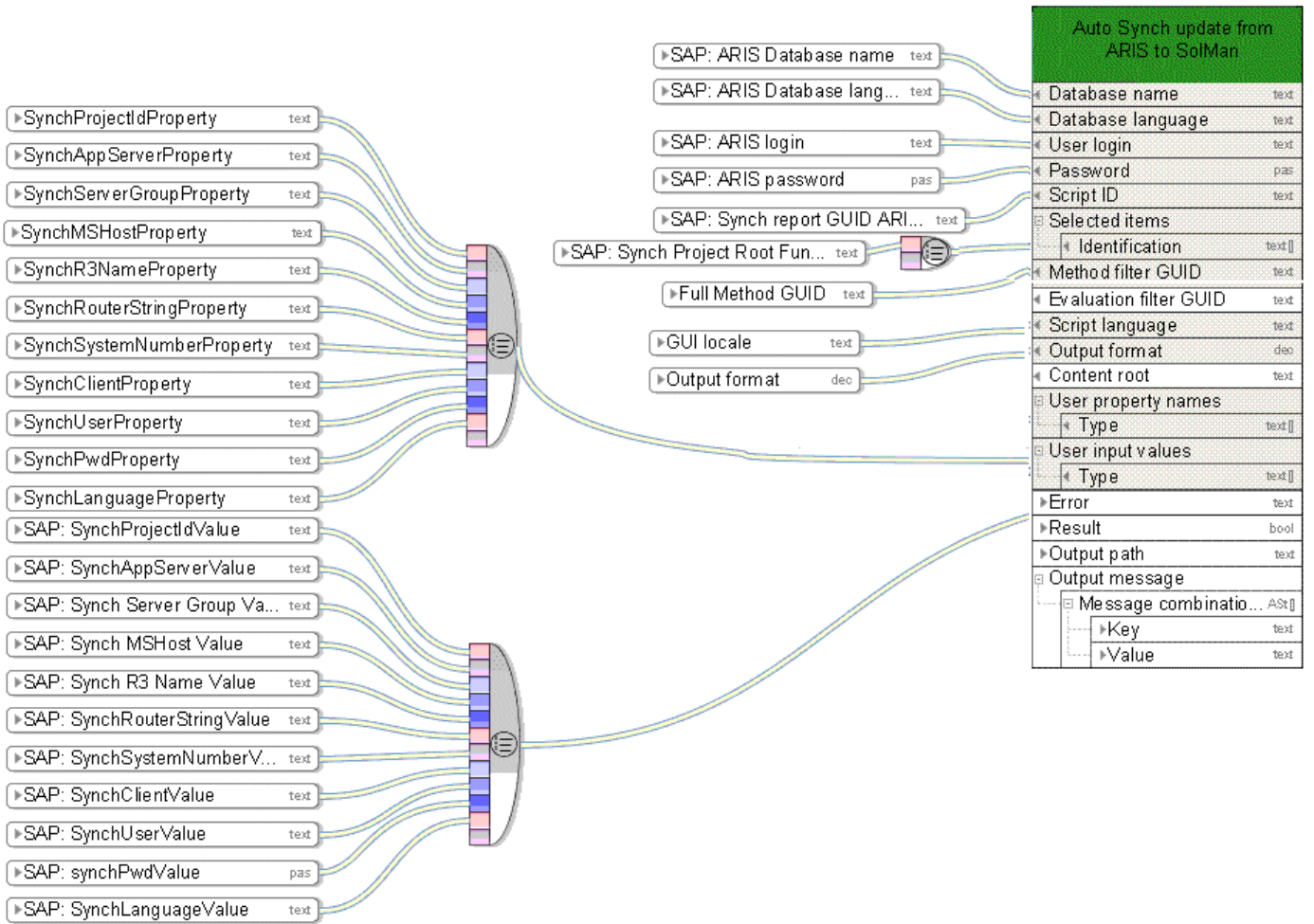









Figure 18: Synchronization with SAP® Solution Manager



### 3.4.10 Create - Shortcut(s)

This service creates shortcuts to existing models or objects.

In/O ut	Name	Details	Data type
	Database name	Name of the database in which the function of type <b>Automated task</b> is carried out.	<Text>
	Database language	Language the service uses for logging in to the database, e.g., <b>en</b> for English. You can specify this in more detail, e. g., <b>en</b> for English or <b>en_US</b> for English (United States). This is helpful, for example, if English (Australia) has been set in the database, but standard English (USA) has not been set.  If you want to add the country, you need to create a language constant and model it as a language in the data flow.	<Text> or <Language>
	User login	Login name of the user that is used for carrying out the <b>Automated task</b> function. If no user is defined, <b>arisservice</b> is used.	<Text>
	Password	Password of the user that is used for carrying out the <b>Automated task</b> function.	<Password>
	Selected items	Select the models or objects you wish to create a shortcut for.	
	Identification	Either connect models, objects, or groups from the preselection of another object of type <b>Human task, Automated task, or Event (process instance started)</b> , or enter GUIDs and use the <b>Create collection</b> operator.	<Text collection>
	Path	Enter the path in which you want to save the new group (e. g., Main group\Processes\Sales processes) in the relevant database using the correct database language.	<Text>
	Error	If automation errors occur, context-specific error messages are displayed indicating, e.g., that ARIS Server is not available.	<Text>
	Result	Returns either TRUE or FALSE (Boolean), depending on whether or not the service was successfully performed.	<Boolean>

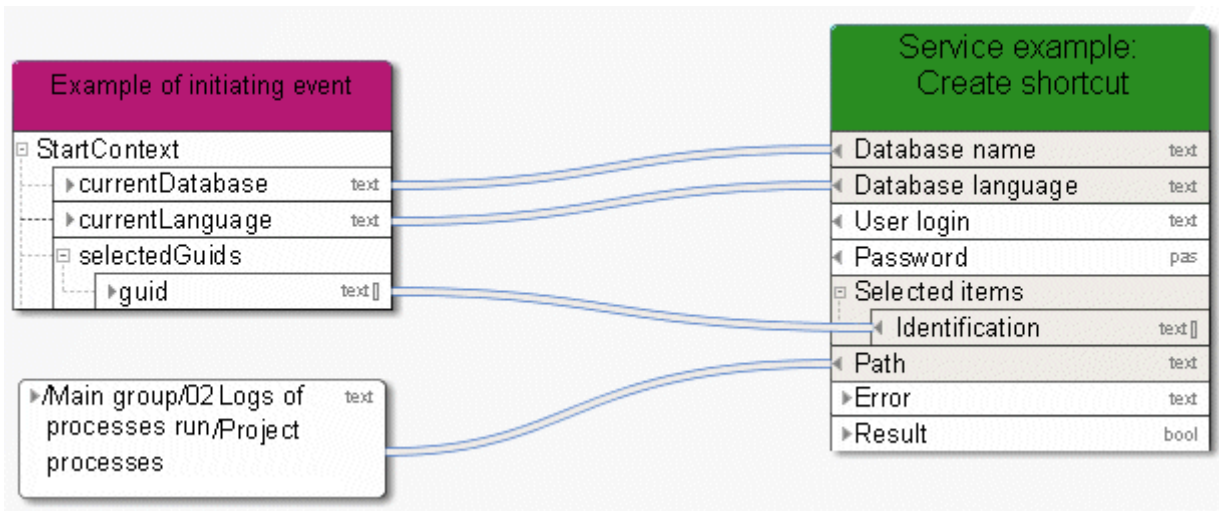





















Figure 20: Create shortcut



### 3.4.11 Create - Static ARIS Publisher export

This service creates Web exports to provide other persons with specific models in read-only mode. The export is static. If a distributed system is used, the export is saved as a ZIP file to ARIS document storage and a link is generated.

In/Out	Name	Details	Data type
	Database name	Name of the database in which the function of type <b>Automated task</b> is carried out.	<Text>
	Database language	Language the service uses for logging in to the database, e.g., <b>en</b> for English. You can specify this in more detail, e. g., <b>en</b> for English or <b>en_US</b> for English (United States). This is helpful, for example, if English (Australia) has been set in the database, but standard English (USA) has not been set.  If you want to add the country, you need to create a language constant and model it as a language in the data flow.	<Text> or <Language>
	User login	Login name of the user that is used for carrying out the <b>Automated task</b> function. If no user is defined, <b>arisservice</b> is used.	<Text>
	Password	Password of the user that is used for carrying out the <b>Automated task</b> function.	<Password>
	Selected items	Select the models or objects for which you want to create a static ARIS Publisher export.	
	Identification	Either connect models, objects, or groups from the preselection of another object of type <b>Human task</b> , <b>Automated task</b> , or <b>Event (process instance started)</b> , or enter GUIDs and use the <b>Create collection</b> operator.	<Text collection>
	Path	Path to the location where the export is saved.	<Text>
	Content root	Object/Model or group representing the starting point of an export.	<Text>
	Generate object pages	An HTML page is created for each object.	
	Object type	Define API names for the objects for which a page is to be created. For example, <b>OT_Func</b> is specified for a function.	<Text>

In/Out	Name	Details	Data type
	Assignment level	Assignment level up to which assigned objects and models are to be exported.	<Decimal>
	Use print scale	Define the Boolean constant as TRUE to display models using the specified print scale, otherwise as FALSE. If no specification is made, the default value FALSE is used.	<Boolean>
	Initial scaling	Define initial scaling, e.g., 100.	<Decimal>
	Scaling	Define the scaling steps for your model, for example: 75,100,125,150.	<Text>
	Black and white	Define the Boolean constant as TRUE to display your model in black and white, otherwise as FALSE. If no specification is made, the default value FALSE is used.	<Boolean>
	Transparent	Define the Boolean constant as TRUE to display your model as transparent, otherwise as FALSE. If no specification is made, the default value FALSE is used.	<Boolean>
	List of document links	Specify the link attributes for which you want to copy documents.	
	Attribute type	Define link attribute types using the API name, e.g., AT_EXT_1 for Link 1, or enter GUIDs and use the <b>Create collection</b> operator.	<Text collection>
	Layout	Select the layout for the ARIS Publisher output, e.g., <b>defaultLayout</b> .	<Text>
	Navigation tree	Defines the structure of the navigation tree in the Publisher export. You can either display the group structure or the hierarchy of the model.	<Text>
	Error	If automation errors occur, context-specific error messages are displayed indicating, e.g., that ARIS Server is not available.	<Text>
	Result	Returns either TRUE or FALSE (Boolean), depending on whether or not the service was successfully performed.	<Boolean>
	Export path	The path where the export result is stored. This can be used as a hyperlink.	<Text>

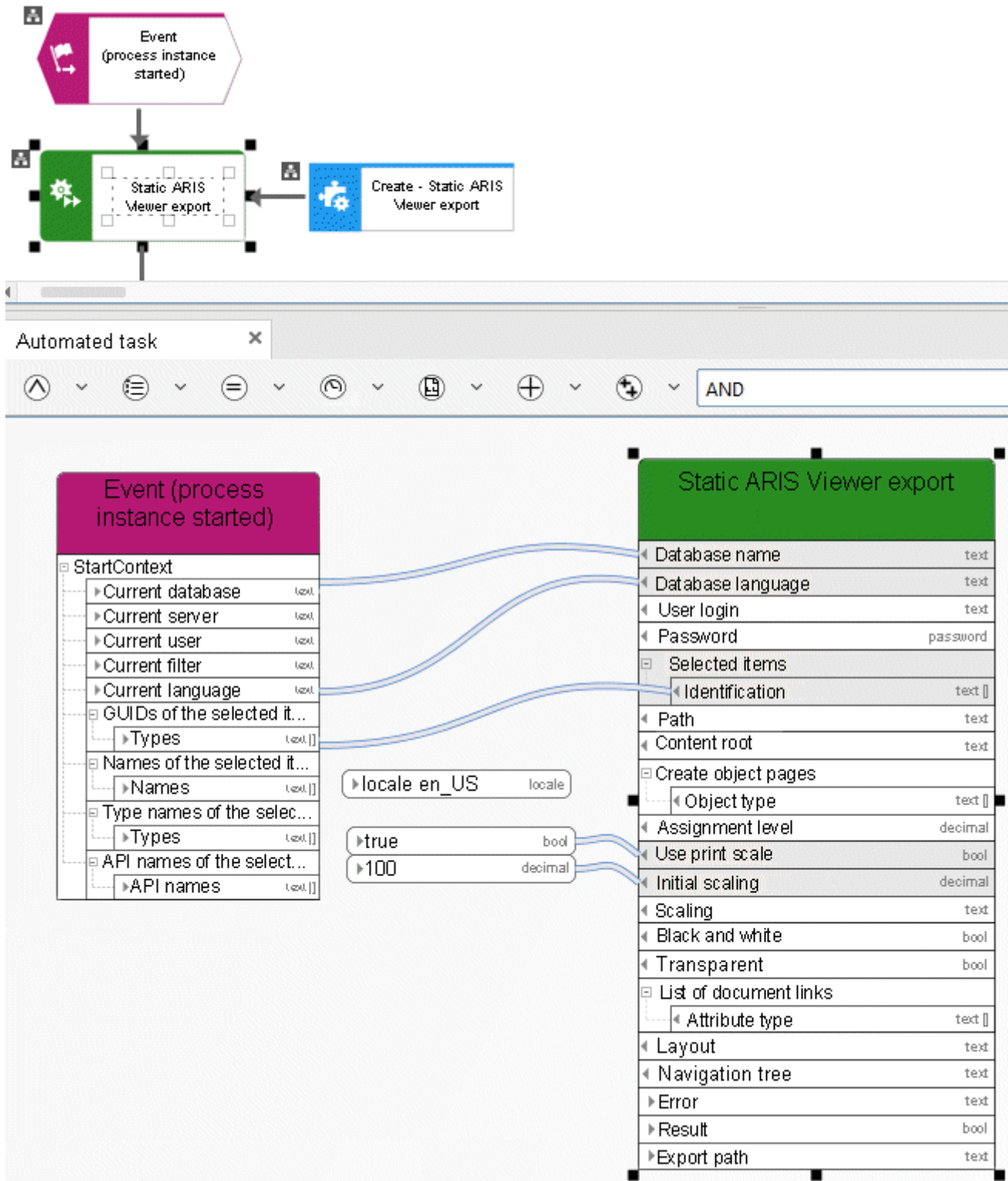















Figure 21: Create static ARIS Publisher export

### 3.4.12 Create - Version

This service creates a new version of the selected models.

In/Out	Name	Details	Data type
	Database name	Name of the database in which the function of type <b>Automated task</b> is carried out.	<Text>
	Database language	Language the service uses for logging in to the database, e.g., <b>en</b> for English. You can specify this in more detail, e. g., <b>en</b> for English or <b>en_US</b> for English (United States). This is helpful, for example, if English (Australia) has been set in the database, but standard English (USA) has not been set.  If you want to add the country, you need to create a language constant and model it as a language in the data flow.	<Text>
	User login	Login name of the user that is used for carrying out the <b>Automated task</b> function. If no user is defined, <b>arisservice</b> is used.	<Text>
	Password	Password of the user that is used for carrying out the <b>Automated task</b> function.	<Password>
	Selected models	Select the models you want to create a version for.	<Text>
	Identification	Either connect models from the preselection of another object of type <b>Human task</b> , <b>Automated task</b> , or <b>Event (process instance started)</b> , or enter GUIDs and use the <b>Create collection</b> operator.	<Text collection>
	Description - Mandatory input	Enter a version description (mandatory input) that applies to all models for which a version was created.	<Text>
	Assignment: Include border items	Specify whether border items are to be included in assignments (Boolean constant = TRUE), or only the items in the selection (Boolean constant = FALSE). If no specification is made, the default value FALSE is used.	<Boolean>
	Connections: Include border items	Specify whether border items are to be included (Boolean constant = TRUE), or only	<Boolean>

In/Out	Name	Details	Data type
		the items in the selection (Boolean constant = FALSE). (If no specification is made, the default value FALSE is used.)	
	Assignment level	Define the assignment level for including assigned models in a version, e.g., 1.	<Decimal>
	Continue execution in case of concurrent versioning	Continue in case another versioning process is already running on the server. The default value is FALSE, that is, the service returns FALSE and fails in case of another versioning procedure is running on the server. If set to TRUE the service waits until it can perform the versioning and does not fail.	<Boolean>
	Error	If automation errors occur, context-specific error messages are displayed indicating, e.g., that ARIS Server is not available.	<Text>
	Result	Returns either TRUE or FALSE (Boolean), depending on whether or not the service was successfully performed.	<Boolean>
	Change list number	The created change list number is output.	<Decimal>
	Concurrent versioning detected	Returns TRUE if another versioning services is running at the same time, and FALSE if not.	<Boolean>

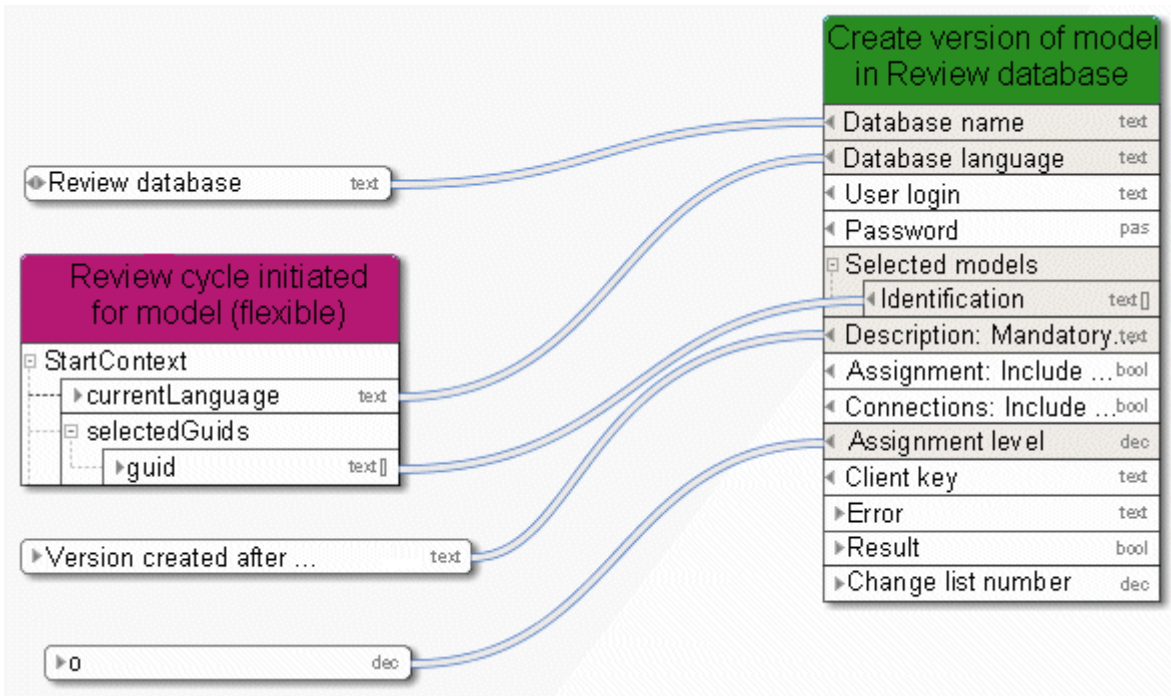







Figure 22: Create version

### 3.4.13 Delete - Database

This service deletes a database.

In/Out	Name	Details	Data type
	Database name	Name of the database in which the function of type <b>Automated task</b> is carried out.	<Text>
	Database language	Language the service uses for logging in to the database, e.g., <b>en</b> for English. You can specify this in more detail, e. g., <b>en</b> for English or <b>en_US</b> for English (United States). This is helpful, for example, if English (Australia) has been set in the database, but standard English (USA) has not been set.  If you want to add the country, you need to create a language constant and model it as a language in the data flow.	<Text> or <Language>
	Password	Password of the user that is used for carrying out the <b>Automated task</b> function.	<Password>
	Database name	Name of the database to be deleted by the <b>Delete database</b> service.	<Text>
	Error	If automation errors occur, context-specific error messages are displayed indicating, e.g., that ARIS Server is not available.	<Text>
	Result	Returns either TRUE or FALSE (Boolean), depending on whether or not the service was successfully performed. If no specification is made, the default value FALSE is used.	<Boolean>

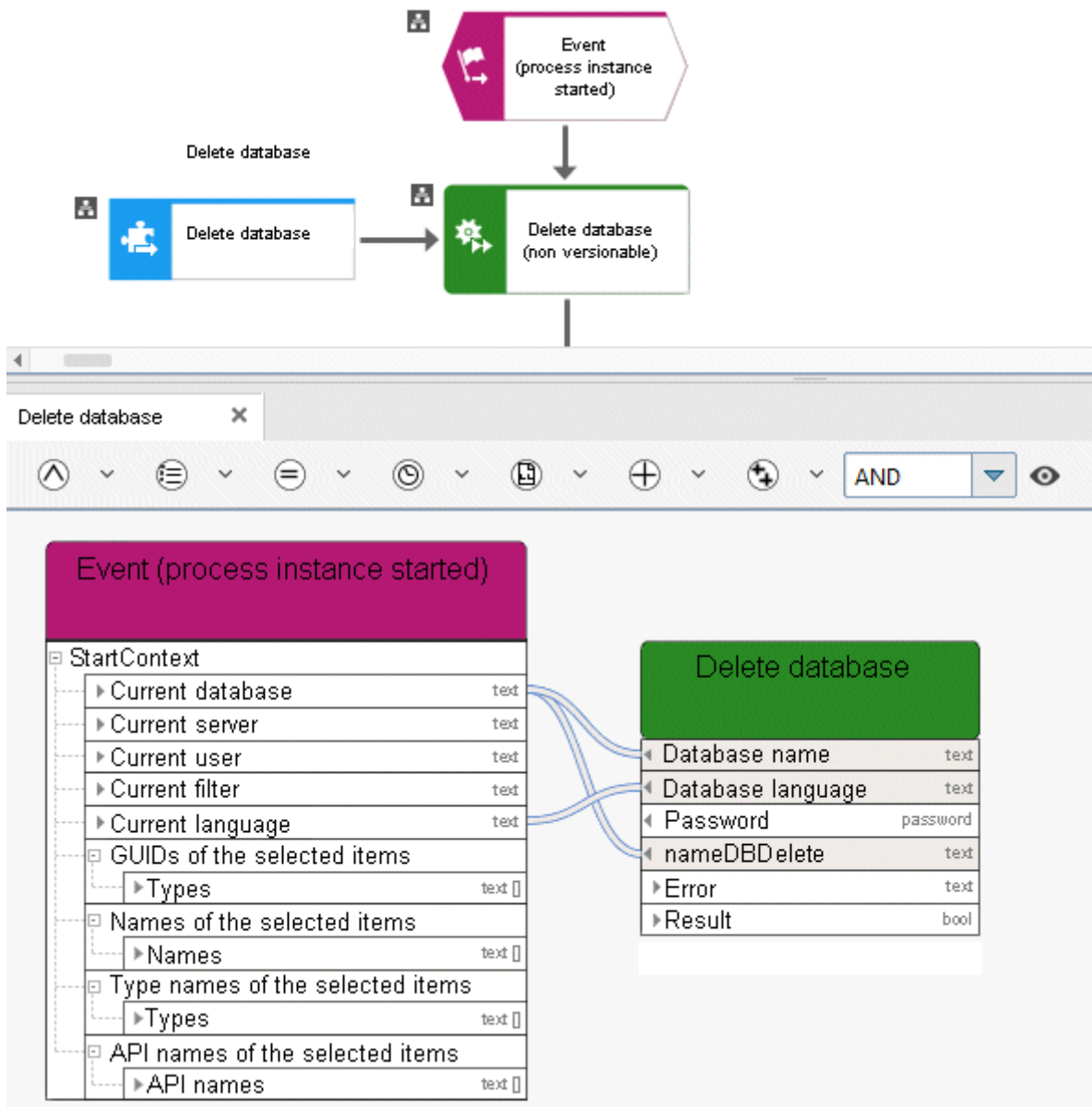









Figure 23: Delete database



### 3.4.14 Delete - Dynamic ARIS Publisher export

This service deletes a dynamic ARIS Publisher export.

In/Out	Name	Details	Data type
	Database name	Name of the database in which the function of type <b>Automated task</b> is carried out.	<Text>
	Database language	Language the service uses for logging in to the database, e.g., <b>en</b> for English. You can specify this in more detail, e. g., <b>en</b> for English or <b>en_US</b> for English (United States). This is helpful, for example, if English (Australia) has been set in the database, but standard English (USA) has not been set.  If you want to add the country, you need to create a language constant and model it as a language in the data flow.	<Text> or <Language>
	User login	Login name of the user that is used for carrying out the <b>Automated task</b> function. If no user is defined, <b>arisservice</b> is used.	<Text>
	Password	Password of the user that is used for carrying out the <b>Automated task</b> function.	<Password>
	ARIS Publisher Server	Name of the ARIS Publisher Server on which the database is stored.	<Text>
	Export name	Name that is displayed in the list when the export opens.	<Text>
	Error	If automation errors occur, context-specific error messages are displayed indicating, e.g., that ARIS Server is not available.	<Text>
	Result	Returns either TRUE or FALSE (Boolean), depending on whether or not the service was successfully performed.	<Boolean>

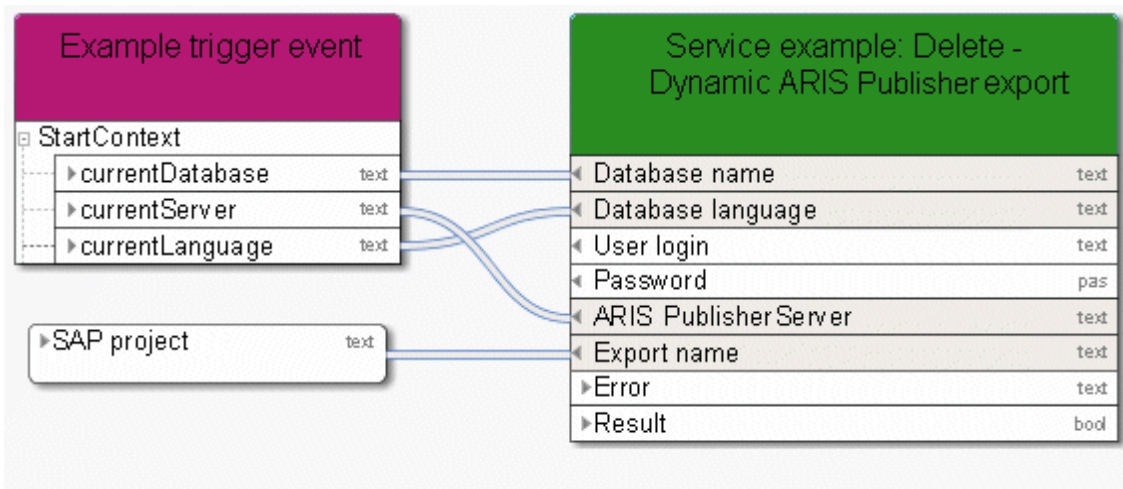









Figure 24: Delete dynamic ARIS Publisher export

### 3.4.15 Delete - Group

This service deletes one or more groups.

In/Out	Name	Details	Data type
	Database name	Name of the database in which the function of type <b>Automated task</b> is carried out.	<Text>
	Database language	Language the service uses for logging in to the database, e.g., <b>en</b> for English. You can specify this in more detail, e. g., <b>en</b> for English or <b>en_US</b> for English (United States). This is helpful, for example, if English (Australia) has been set in the database, but standard English (USA) has not been set.  If you want to add the country, you need to create a language constant and model it as a language in the data flow.	<Text> or <Language>
	User login	Login name of the user that is used for carrying out the <b>Automated task</b> function. If no user is defined, <b>arisservice</b> is used.	<Text>
	Password	Password of the user that is used for carrying out the <b>Automated task</b> function.	<Password>
	Selected items	The group(s) to be deleted. The input has to be a collection of the group IDs – groups as selected items.	
	Group(s) to be deleted - Specified by group ID	Group ID or group IDs of the groups to be deleted. The input has to be a collection of group IDs – groups as group IDs.	<Text collection>
	Group(s) to be deleted - Specified by group path	Group path or group paths of the groups to be deleted. The input has to be a collection of group paths – groups as group paths.	<Text collection>
	Error	If automation errors occur, context-specific error messages are displayed indicating, e.g., that ARIS Server is not available.	<Text>
	Result	Returns either TRUE or FALSE (Boolean), depending on whether or not the service was successfully performed.	<Boolean>

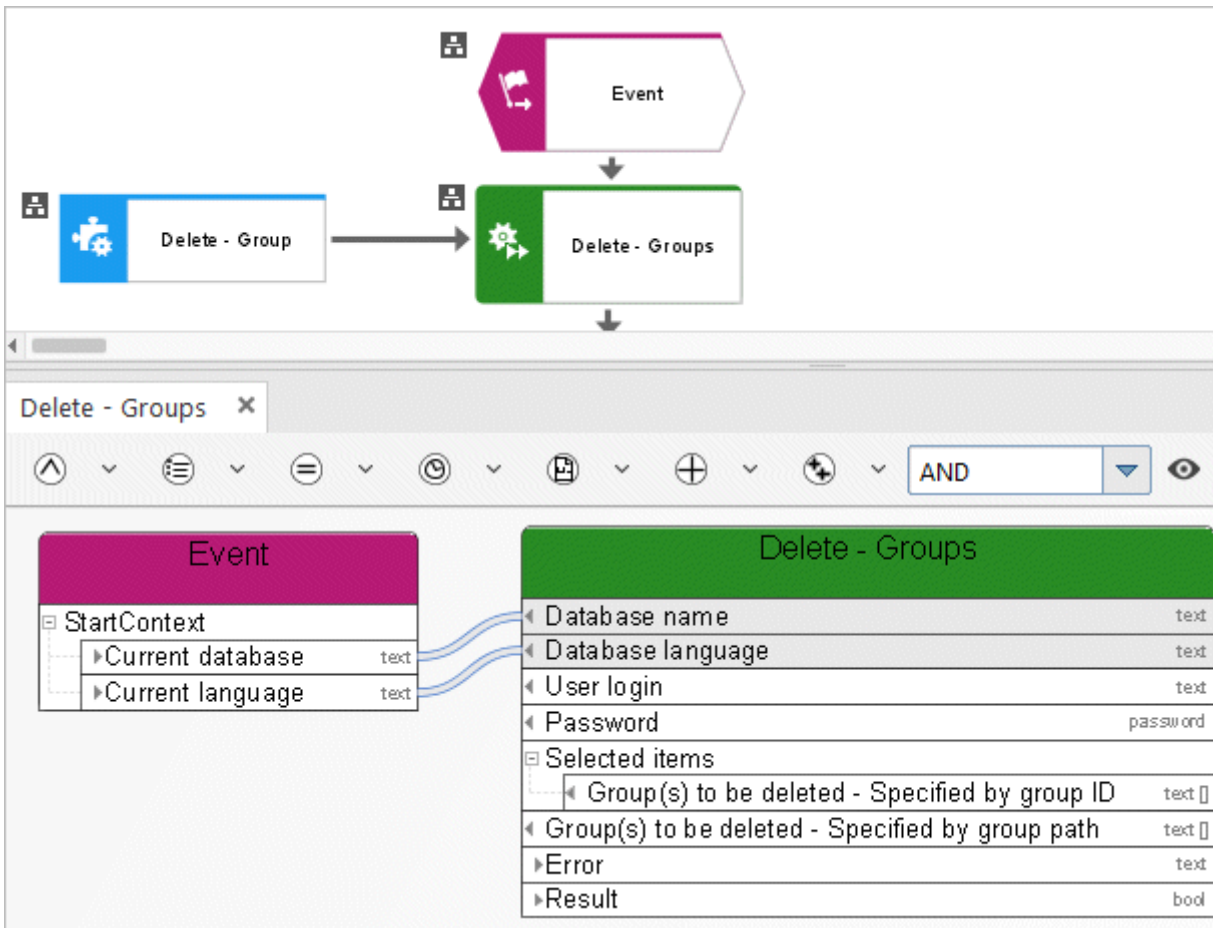









Figure 25: Delete group

### 3.4.16 Delete - Model(s)

This service deletes existing models together with their objects.

In/Out	Name	Details	Data type
	Database name	Name of the database in which the function of type <b>Automated task</b> is carried out.	<Text>
	Database language	Language the service uses for logging in to the database, e.g., <b>en</b> for English. You can specify this in more detail, e. g., <b>en</b> for English or <b>en_US</b> for English (United States). This is helpful, for example, if English (Australia) has been set in the database, but standard English (USA) has not been set.  If you want to add the country, you need to create a language constant and model it as a language in the data flow.	<Text> or <Language>
	User login	Login name of the user that is used for carrying out the <b>Automated task</b> function. If no user is defined, <b>arisservice</b> is used.	<Text>
	Password	Password of the user that is used for carrying out the <b>Automated task</b> function.	<Password>
	Selected models	Select the models to be deleted.	
	Identification	Either connect objects of another object of type <b>Human task</b> , <b>Automated task</b> , or <b>Event (process instance started)</b> , or enter GUIDs and use the <b>Create collection</b> operator.	<Text collection>
	Error	If automation errors occur, context-specific error messages are displayed indicating, e.g., that ARIS Server is not available.	<Text>
	Result	Returns either TRUE or FALSE (Boolean), depending on whether or not the service was successfully performed.	<Boolean>

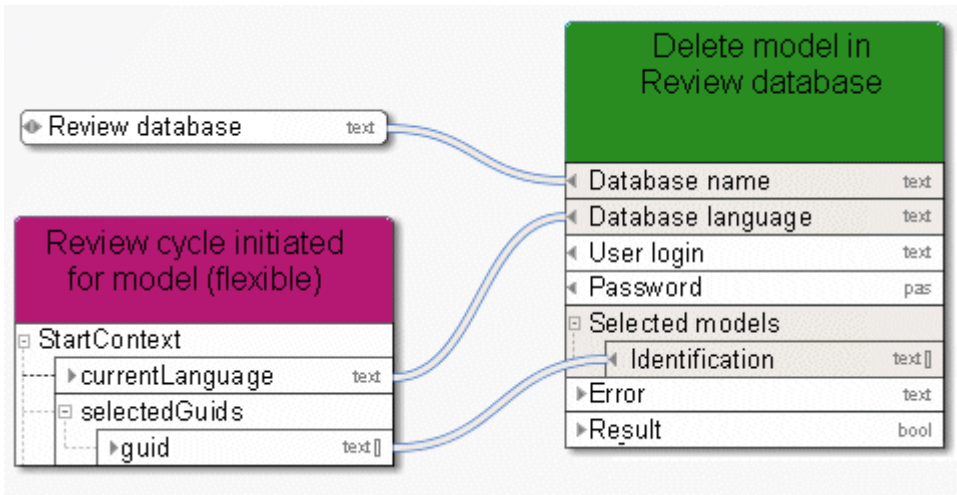









Figure 26: Delete models

### 3.4.17 Delete - Object(s)

This service deletes existing objects.

In/Out	Name	Details	Data type
	Database name	Name of the database in which the function of type <b>Automated task</b> is carried out.	<Text>
	Database language	Language the service uses for logging in to the database, e.g., <b>en</b> for English. You can specify this in more detail, e. g., <b>en</b> for English or <b>en_US</b> for English (United States). This is helpful, for example, if English (Australia) has been set in the database, but standard English (USA) has not been set.  If you want to add the country, you need to create a language constant and model it as a language in the data flow.	<Text> or <Language>
	User login	Login name of the user that is used for carrying out the <b>Automated task</b> function. If no user is defined, <b>arisservice</b> is used.	<Text>
	Password	Password of the user that is used for carrying out the <b>Automated task</b> function.	<Password>
	Selected objects	Select the objects to be deleted.	
	Identification	Either connect objects of another object of type <b>Human task</b> , <b>Automated task</b> , or <b>Event (process instance started)</b> , or enter GUIDs and use the <b>Create collection</b> operator.	<Text collection>
	Error	If automation errors occur, context-specific error messages are displayed indicating, e.g., that ARIS Server is not available.	<Text>
	Result	Returns either TRUE or FALSE (Boolean), depending on whether or not the service was successfully performed.	<Boolean>

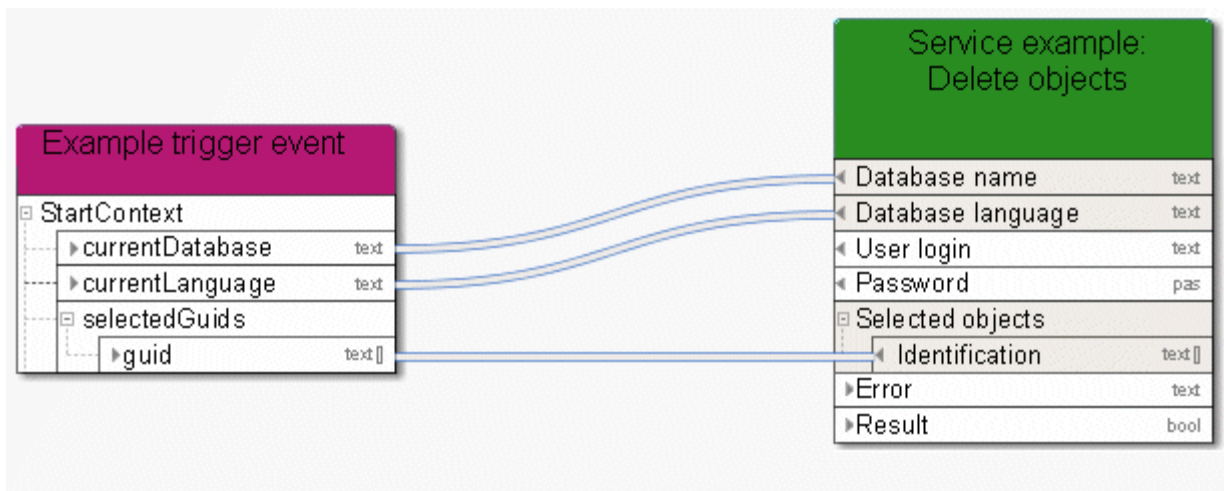



Figure 27: Delete objects



### 3.4.18 Delete - Temporary files

The **Delete temporary files** service deletes temporary files that can accumulate when using Process Governance. Usage of this service is configured in ARIS Administration. Files are deleted from the directory defined for the static export of ARIS Publisher. This works only in a non-distributed scenario in which everything is installed on a single server. If these paths differ from the default paths, you can configure them in ARIS Administration (property **com.idsscheer.age.serviceenabling.staticExport.exportDir**). In distributed systems, the service deletes the directory **aris-serviceenabling** and all the documents and subdirectories it contains from ARIS document storage.

In/Output	Name	Details	Data type
	Result	Returns either TRUE or FALSE (Boolean), depending on whether or not the service was successfully performed.	<Boolean>
	Error	If it was impossible to delete all temporary files a corresponding error message will be displayed.	<Text>

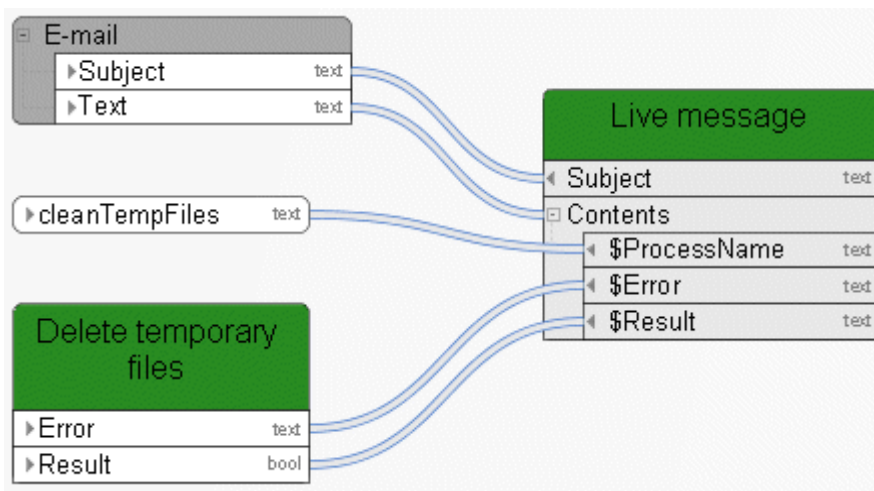









Figure 28: Delete temporary files

### 3.4.19 Lock - Model(s)/Object(s)

This service locks models and/or objects. You can select the models or objects you want to lock.

In/Output	Name	Details	Data type
	Database name	Name of the database in which the function of type <b>Automated task</b> is carried out.	<Text>
	Database language	Language the service uses for logging in to the database, e.g., <b>en</b> for English. You can specify this in more detail, e. g., <b>en</b> for English or <b>en_US</b> for English (United States). This is helpful, for example, if English (Australia) has been set in the database, but standard English (USA) has not been set.  If you want to add the country, you need to create a language constant and model it as a language in the data flow.	<Text> or <Language>
	User login	Login name of the user that is used for carrying out the <b>Automated task</b> function. If no user is defined, <b>arisservice</b> is used.	<Text>
	Password	Password of the user that is used for carrying out the <b>Automated task</b> function.	<Password>
	Selected items	Selected models or objects you want to lock.	
	Identification	Either connect models or objects from the preselection of another object of type <b>Human task</b> , <b>Automated task</b> , or <b>Event (process instance started)</b> , or enter GUIDs and use the <b>Create collection</b> operator.	<Text collection>
	Include objects	Include associated objects when locking models. To do this, define the Boolean constant as TRUE, otherwise as FALSE. If no specification is made, the default value FALSE is used.	<Boolean>
	Use current user for locking	If the current user is assigned to the corresponding field in the data flow via a connection, locking models or objects is performed as if the current user were doing it	<Text>

In/Out	Name	Details	Data type
		manually. This means that the personal privileges of the current user are taken into account, not the privileges of user <b>arisservice</b> actually performing the service.	
←	Error	If automation errors occur, context-specific error messages are displayed indicating, e.g., that ARIS Server is not available.	<Text>
←	Result	Returns either TRUE or FALSE (Boolean), depending on whether or not the service was successfully performed.	<Boolean>

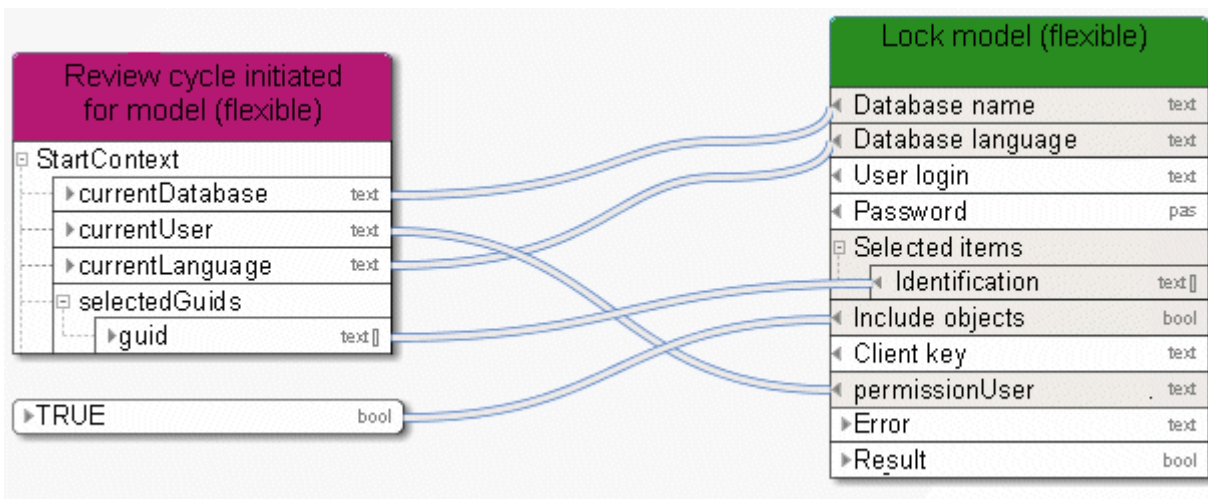









Figure 29: Lock models and objects

### 3.4.20 Move - Models/Objects (within database)

This service moves models or objects within the database.

In/Out	Name	Details	Data type
	Database name	Name of the database in which the function of type <b>Automated task</b> is carried out.	<Text>
	Database language	Language the service uses for logging in to the database, e.g., <b>en</b> for English. You can specify this in more detail, e. g., <b>en</b> for English or <b>en_US</b> for English (United States). This is helpful, for example, if English (Australia) has been set in the database, but standard English (USA) has not been set.  If you want to add the country, you need to create a language constant and model it as a language in the data flow.	<Text> or <Language>
	User login	Name of the database in which the function of type <b>Automated task</b> is carried out.	<Text>
	Password	Password of the user that is used for carrying out the <b>Automated task</b> function.	<Password>
	Selected items	Select the models or objects you want to move.	
	Identification	Either connect models or objects from the preselection of another object of type <b>Human task</b> , <b>Automated task</b> , or <b>Event (process instance started)</b> , or enter GUIDs and use the <b>Create collection</b> operator.	<Text collection>
	Target path	Enter the path to which you want to move models or objects (e.g., <b>Main group\Processes\Sales processes</b> ) in the correct database language.	<Text>
	Move related objects	Define the Boolean constant as TRUE to include objects when moving models. If no specification is made, the default value FALSE is used.	<Boolean>
	Error	If automation errors occur, context-specific error messages are displayed indicating, e.g., that ARIS Server is not available.	<Text>

In/O ut	Name	Details	Data type
◀	Result	Returns either TRUE or FALSE (Boolean), depending on whether or not the service was successfully performed.	<Boolean>

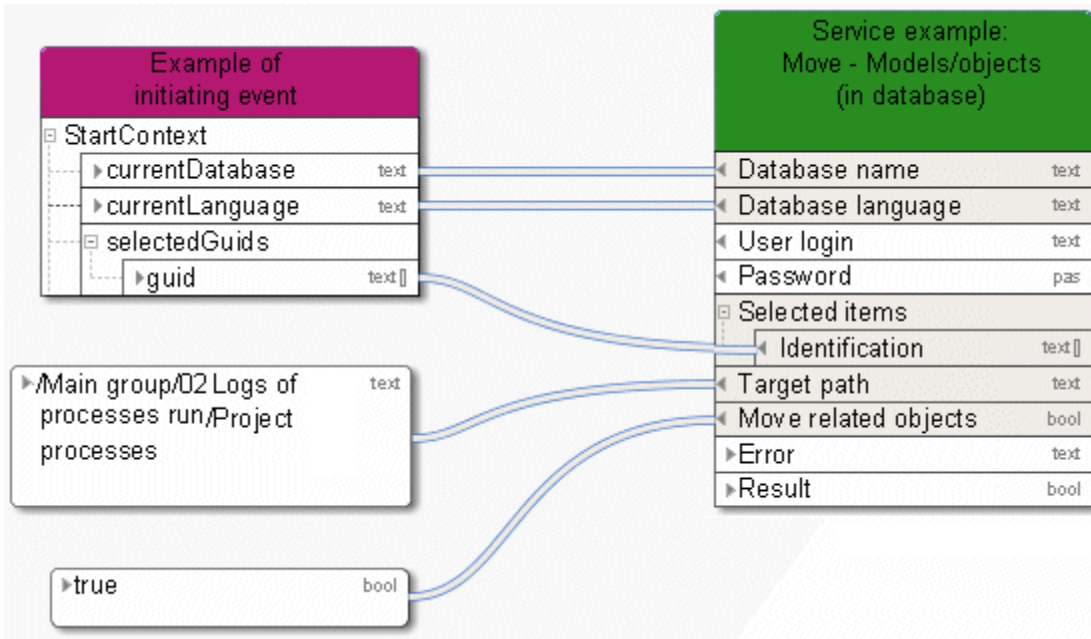







Figure 30: Move models/objects within the database

### 3.4.21 Reorganize - Database

This service deletes all objects and connections that do not have any occurrences in a model or dataflow.

In/Output	Name	Details	Data type
	Database name	Name of the database in which the function of type <b>Automated task</b> is carried out.	<Text>
	Database language	Language the service uses for logging in to the database, e.g., <b>en</b> for English. You can specify this in more detail, e. g., <b>en</b> for English or <b>en_US</b> for English (United States). This is helpful, for example, if English (Australia) has been set in the database, but standard English (USA) has not been set.  If you want to add the country, you need to create a language constant and model it as a language in the data flow.	<Text> or <Language>
	User login	Login name of the user that is used for carrying out the <b>Automated task</b> function. If no user is defined, <b>arisservice</b> is used.	<Text>
	Password	Password of the user that is used for carrying out the <b>Automated task</b> function.	<Password>
	Result	The result is TRUE if the reorganizing process was successfully executed. If not, it returns FALSE.	<Boolean>
	Deleted objects	A list with all objects and connections to be deleted.	<Text>

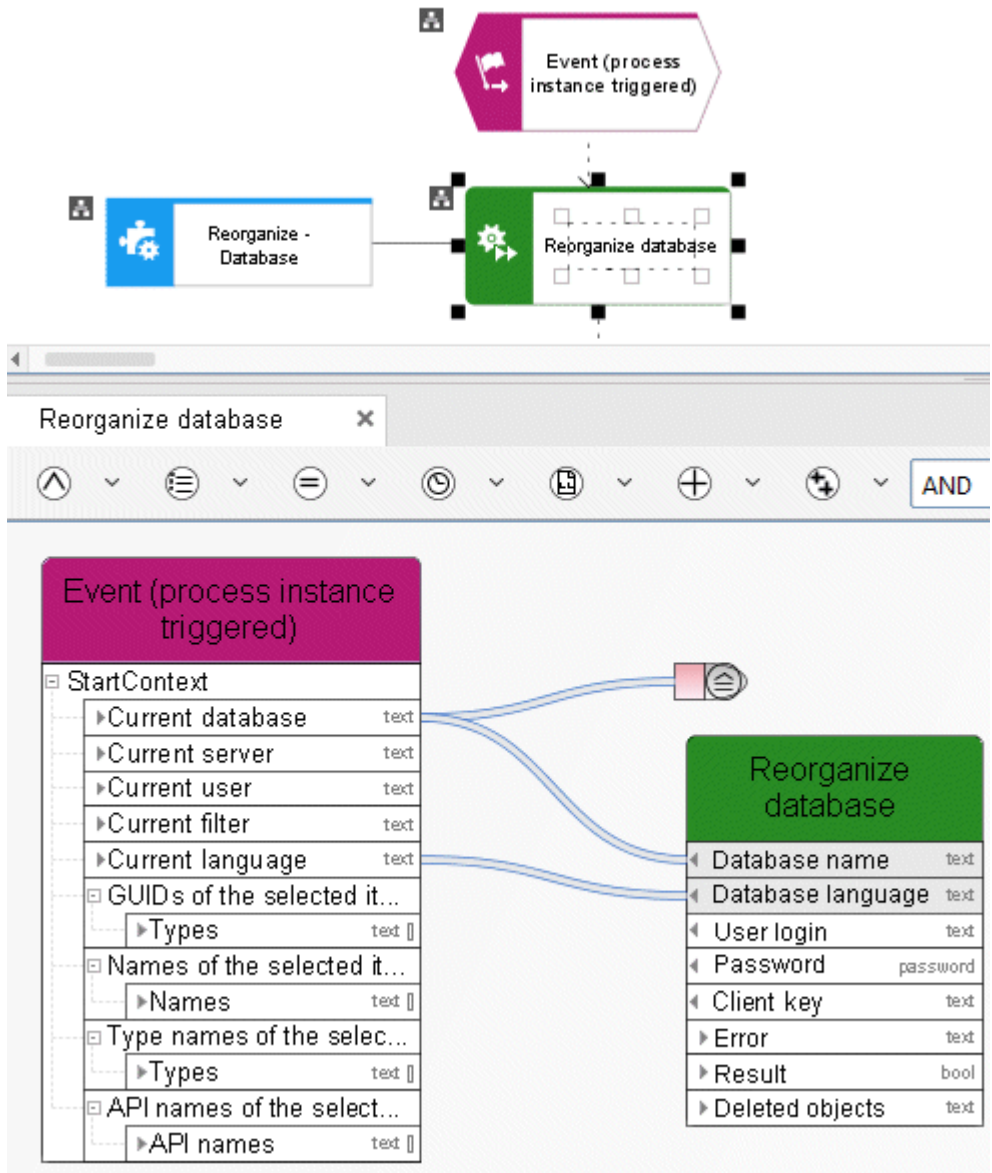







Figure 31: Reorganize database

### 3.4.22 Retrieve - 1 (superior) directory attribute

This service retrieves exactly one attribute (e. g., 'Description') from a group. If the requested attribute is not specified, the service continues retrieving the corresponding attribute from the superior group until a specified attribute is found or the main group is reached.

In/O ut	Name	Details	Data type
	Database name	Name of the database in which the function of type <b>Automated task</b> is carried out.	<Text>
	Database language	Language the service uses for logging in to the database, e.g., <b>en</b> for English. You can specify this in more detail, e. g., <b>en</b> for English or <b>en_US</b> for English (United States). This is helpful, for example, if English (Australia) has been set in the database, but standard English (USA) has not been set.  If you want to add the country, you need to create a language constant and model it as a language in the data flow.	<Text> or <Language>
	User login	Login name of the user that is used for carrying out the <b>Automated task</b> function. If no user is defined, <b>arisservice</b> is used.	<Text>
	Password	Password of the user that is used for carrying out the <b>Automated task</b> function.	<Password>
	Selected items	Exactly one attribute is retrieved from multiple groups, e.g., the attribute <b>Description/Definition</b> . Groups can also be identified by selecting multiple models or objects. In this case, groups containing these models and objects are selected.	
	Identification	Either connect models, objects, or groups from the preselection of another object of type <b>Human task, Automated task, or Event (process instance started)</b> , or enter GUIDs and use the <b>Create collection</b> operator. The group containing the selected items is identified.	<Text collection>
	(Superior) group attribute to be retrieved	The selected attribute is retrieved (exactly one group attribute from multiple groups). If the group attribute is empty, retrieval of the	<Text>



In/O ut	Name	Details	Data type
		attribute of the superior group continues until a specified attribute is found or the main group is reached. Either connect a group attribute type from the preselection of another object of the <b>Human task, Automated task, or Event (process instance started)</b> type, or enter the API name or a GUID.	
➡	Use default language	If this is defined as TRUE, the alternative language of the database is used in case of a missing language.	<Boolean>
⬅	Error	If automation errors occur, context-specific error messages are displayed indicating, e.g., that ARIS Server is not available.	<Text>
⬅	Result	Returns either TRUE or FALSE (Boolean), depending on whether or not the service was successfully performed.	<Boolean>
⬅	Values	Required attribute values are returned in a list.	<Text collection>

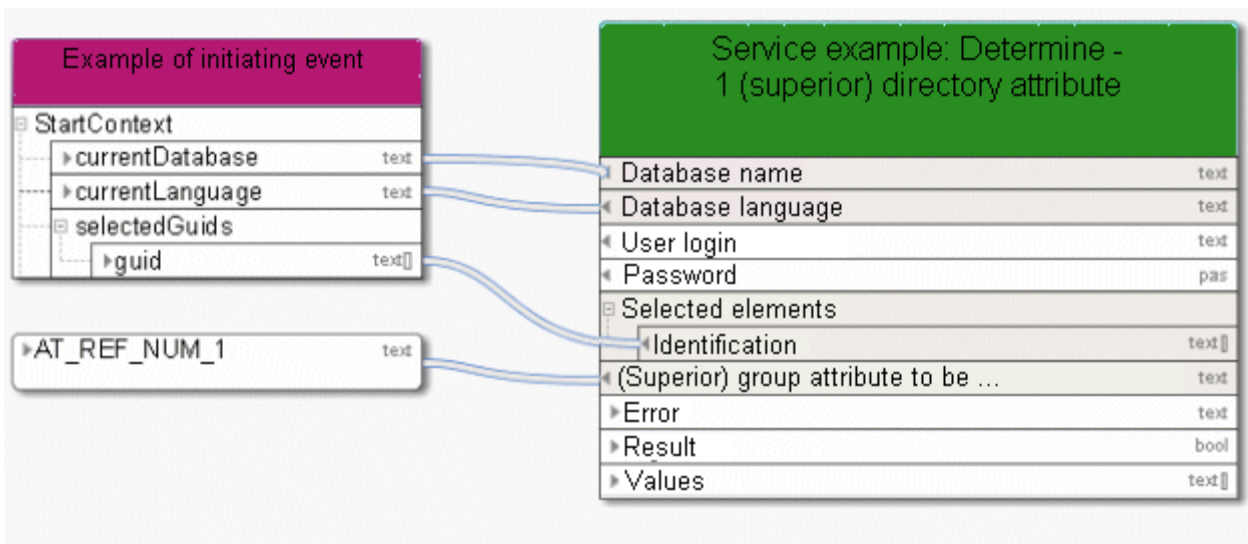











Figure 32: Retrieve exactly one (superior) group attribute

### 3.4.23 Retrieve - 1 attribute in multiple elements

This service retrieves exactly one attribute (e. g., 'Description') from models, objects, or groups.

In/Output	Name	Details	Data type
	Database name	Name of the database in which the function of type <b>Automated task</b> is carried out.	<Text>
	Database language	Language the service uses for logging in to the database, e.g., <b>en</b> for English. You can specify this in more detail, e. g., <b>en</b> for English or <b>en_US</b> for English (United States). This is helpful, for example, if English (Australia) has been set in the database, but standard English (USA) has not been set.  If you want to add the country, you need to create a language constant and model it as a language in the data flow.	<Text> or <Language>
	User login	Login name of the user that is used for carrying out the <b>Automated task</b> function. If no user is defined, <b>arisservice</b> is used.	<Text>
	Password	Password of the user that is used for carrying out the <b>Automated task</b> function.	<Password>
	Selected items	Exactly one attribute is retrieved from multiple models, objects, or groups, e.g., the attribute <b>Description/Definition</b> .	
	Identification	Either connect models, objects, or groups from the preselection of another object of type <b>Human task</b> , <b>Automated task</b> , or <b>Event (process instance started)</b> , or enter GUIDs and use the <b>Create collection</b> operator.	<Text collection>
	Attribute to be retrieved	The selected attribute is retrieved (exactly one attribute of multiple items, e.g., models).	<Text>
	Use default language	Specifies whether the default language for the database is to be used (TRUE) or not (FALSE).	<Boolean>
	Error	If automation errors occur, context-specific error messages are displayed indicating, e.g., that ARIS Server is not available.	<Text>
	Result	Returns either TRUE or FALSE (Boolean),	<Boolean>

In/O ut	Name	Details	Data type
		depending on whether or not the service was successfully performed.	
←	Values	Required attribute values are returned in a list.	<Text collection>

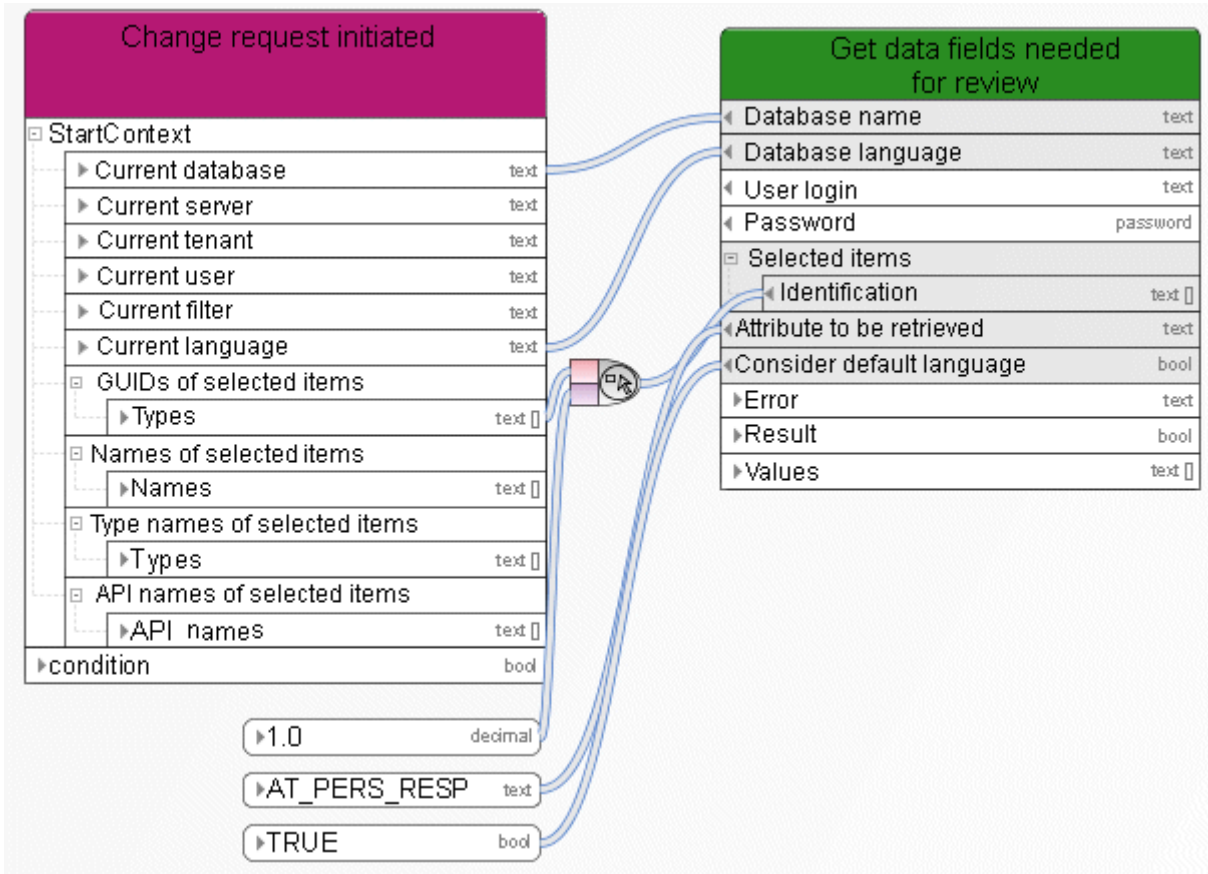









Figure 33: Retrieve exactly one attribute from multiple items

### 3.4.24 Retrieve - ARIS user group attributes

This service selects an ARIS user group and returns the user group attributes.

In/Out	Name	Details	Data type
	Database name	Name of the database in which the function of type <b>Automated task</b> is carried out.	<Text>
	Database language	Language the service uses for logging in to the database, e.g., <b>en</b> for English. You can specify this in more detail, e. g., <b>en</b> for English or <b>en_US</b> for English (United States). This is helpful, for example, if English (Australia) has been set in the database, but standard English (USA) has not been set.  If you want to add the country, you need to create a language constant and model it as a language in the data flow.	<Text> or <Language>
	User login	Login name of the user that is used for carrying out the <b>Automated task</b> function. If no user is defined, <b>arisservice</b> is used.	<Text>
	Password	Password of the user that is used for carrying out the <b>Automated task</b> function.	<Password>
	Name of the user group	Enter the name of the ARIS database user group from which you want to retrieve attributes.	<Text>
	Error	If automation errors occur, context-specific error messages are displayed indicating, e.g., that ARIS Server is not available.	<Text>
	Result	Returns either TRUE or FALSE (Boolean), depending on whether or not the service was successfully performed.	<Boolean>
	Values	The attribute value list of the user group in the ARIS database is output.	<Text collection>

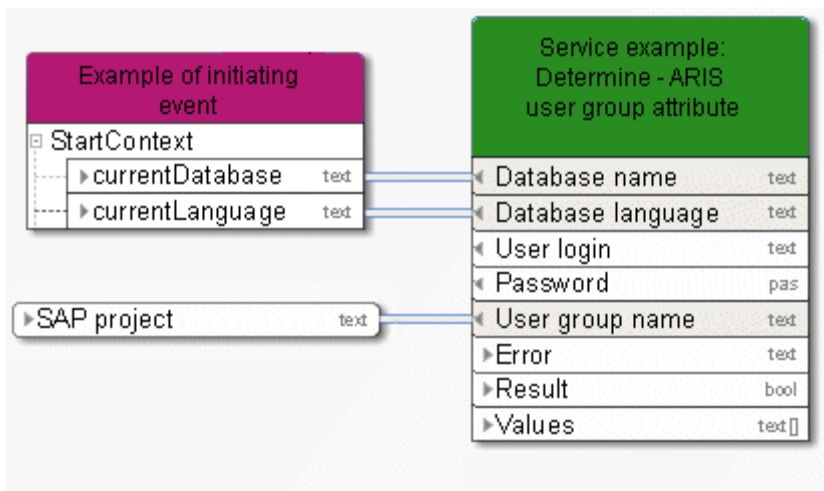









Figure 34: Determine attributes from ARIS user group

### 3.4.25 Retrieve - Current technical version of model(s)

This service selects the latest change list (current models) for the required models from the list of available versions.

In/Output	Name	Details	Data type
	Database name	Name of the database in which the function of type <b>Automated task</b> is carried out.	<Text>
	Database language	Language the service uses for logging in to the database, e.g., <b>en</b> for English. You can specify this in more detail, e. g., <b>en</b> for English or <b>en_US</b> for English (United States). This is helpful, for example, if English (Australia) has been set in the database, but standard English (USA) has not been set.  If you want to add the country, you need to create a language constant and model it as a language in the data flow.	<Text> or <Language>
	User login	Login name of the user that is used for carrying out the <b>Automated task</b> function. If no user is defined, <b>arisservice</b> is used.	<Text>
	Password	Password of the user that is used for carrying out the <b>Automated task</b> function.	<Password>
	Identification	Either connect models, objects, or groups from the preselection of another object of type <b>Human task</b> , <b>Automated task</b> , or <b>Event (process instance started)</b> , or enter GUIDs and use the <b>Create collection</b> operator.	<Text collection>
	Error	If automation errors occur, context-specific error messages are displayed indicating, e.g., that ARIS Server is not available.	<Text>
	Result	Returns either TRUE or FALSE (Boolean), depending on whether or not the service was successfully performed.	<Boolean>
	Change list	The <b>Current version</b> change list number will be returned for each model.	<Decimal collection>

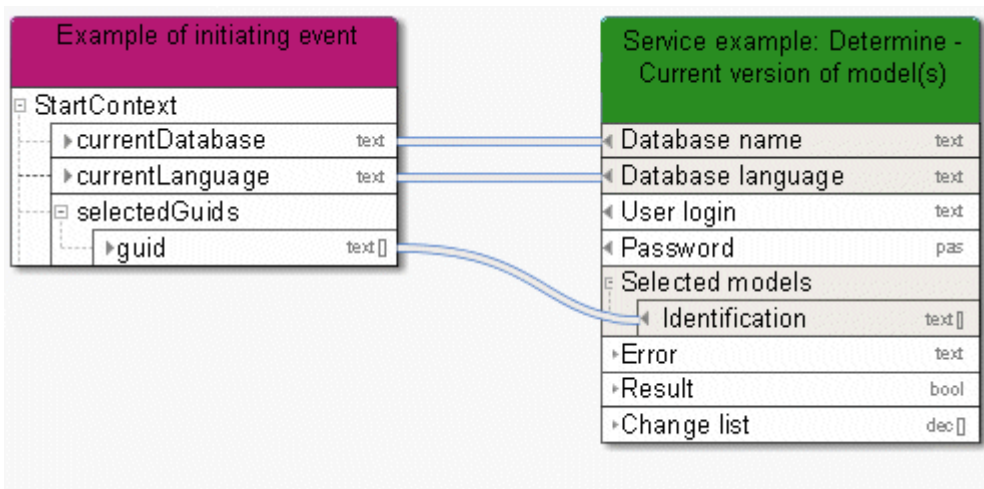









Figure 35: Select current model version

### 3.4.26 Retrieve - Element(s) based on Attribute(s)

This service finds items (e.g., models) according to given attribute values. These items can be used for further processing.

In/Output	Name	Details	Data type
	Database name	Name of the database in which the function of type <b>Automated task</b> is carried out.	<Text>
	Database language	Language the service uses for logging in to the database, e.g., <b>en</b> for English. You can specify this in more detail, e. g., <b>en</b> for English or <b>en_US</b> for English (United States). This is helpful, for example, if English (Australia) has been set in the database, but standard English (USA) has not been set.  If you want to add the country, you need to create a language constant and model it as a language in the data flow.	<Text> or <Language>
	User login	Login name of the user that is used for carrying out the <b>Automated task</b> function. If no user is defined, <b>arisservice</b> is used.	<Text>
	Password	Password of the user that is used for carrying out the <b>Automated task</b> function.	<Password>
	Search value	Lists the attribute values to be used to find items. The precise attribute value must be entered; wildcards such as an asterisk (*) or question mark (?) are not allowed.	<Text collection>
	Attribute types	Specifies the attribute types to be browsed for the corresponding search value.	
	Type	Either connect the attribute types of models, objects, or groups from the preselection of another object of type <b>Human task</b> , <b>Automated task</b> , or <b>Event (process instance started)</b> , or enter GUIDs and use the <b>Create collection</b> operator.	<Text collection>
	Item types	Select the models or objects you want to find.	
	Type	Either connect models, objects, or groups from the preselection of another object of type <b>Human task</b> , <b>Automated task</b> , or <b>Event</b>	<Text collection>





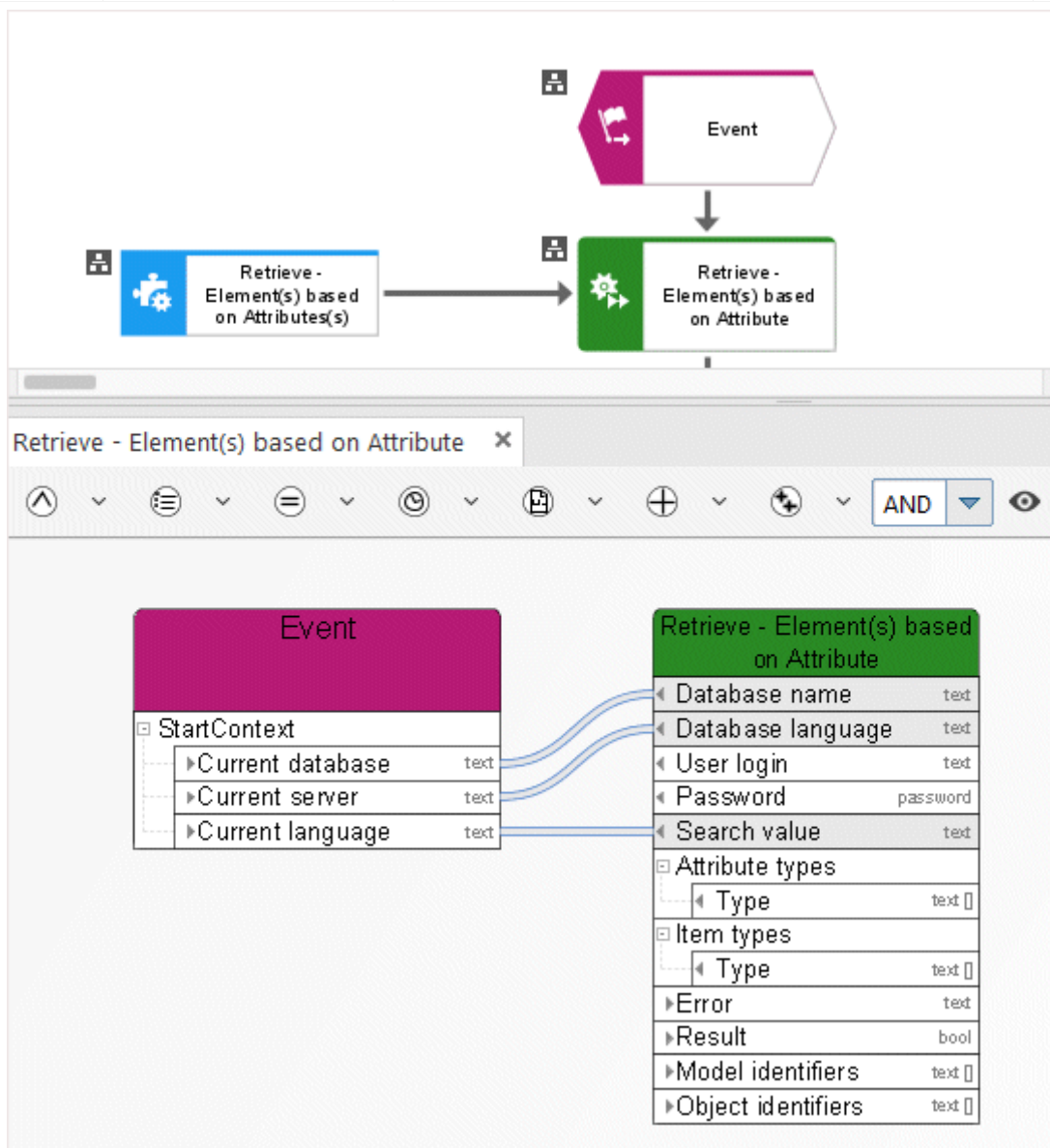





In/O ut	Name	Details	Data type
		<b>(process instance started)</b> , or enter GUIDs and use the <b>Create collection</b> operator.	
⬅	Error	If automation errors occur, context-specific error messages are displayed indicating, e.g., that ARIS Server is not available.	<Text>
⬅	Result	Returns the list of all items found, e.g., models.	<Text collection>
⬅	Model identifiers	Returns the list of GUIDs of the models found.	<Text collection>
⬅	Object identifiers	Returns the list of GUIDs of the objects found.	<Text collection>



### 3.4.27 Retrieve - Element(s) based on GUID(s)

This service finds all items (e. g., models) according to a predefined GUID list. These items can be used for further processing.

In/Output	Name	Details	Data type
	Database name	Name of the database in which the function of type <b>Automated task</b> is carried out.	<Text>
	Database language	Language the service uses for logging in to the database, e.g., <b>en</b> for English. You can specify this in more detail, e. g., <b>en</b> for English or <b>en_US</b> for English (United States). This is helpful, for example, if English (Australia) has been set in the database, but standard English (USA) has not been set.  If you want to add the country, you need to create a language constant and model it as a language in the data flow.	<Text> or <Language>
	User login	Login name of the user that is used for carrying out the <b>Automated task</b> function. If no user is defined, <b>arisservice</b> is used.	<Text>
	Password	Password of the user that is used for carrying out the <b>Automated task</b> function.	<Password>
	Selected items	Select the models or objects you want to find.	
	Identification	Either connect models, objects, or groups from the preselection of another object of type <b>Human task, Automated task, or Event (process instance started)</b> , or enter GUIDs and use the <b>Create collection</b> operator.	<Text collection>
	Error	If automation errors occur, context-specific error messages are displayed indicating, e.g., that ARIS Server is not available.	<Text>
	Result	Returns either TRUE or FALSE (Boolean), depending on whether or not the service was successfully performed.	<Boolean>
	Items found	Returns the list of all items found, e.g., models.	
	GUIDs	The list of GUIDs is output for the items that were found.	<Text collection>
	Items not found	Returns the list of all items that were not	

In/O ut	Name	Details	Data type
		found, e. g., models.	
⬅	GUIDs	The list of GUIDs is output for the items that were not found.	<Text collection>

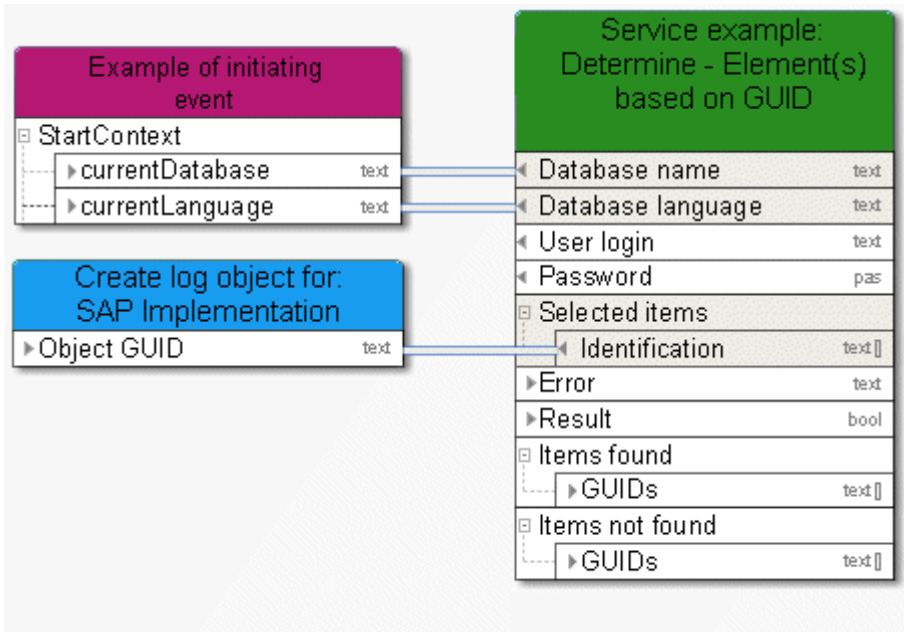

Figure 36: Find items via GUID

### 3.4.28 Retrieve - Group path

This service retrieves the group path for models and objects.

In/Output	Name	Details	Data type
⬅	Error	If automation errors occur, context-specific error messages are displayed indicating, e.g., that ARIS Server is not available.	<Text>
➡	GUID	List of the GUIDs of the models and objects.	<Text collection>
⬅	Result	Path of the respective model or object.	<Text collection>

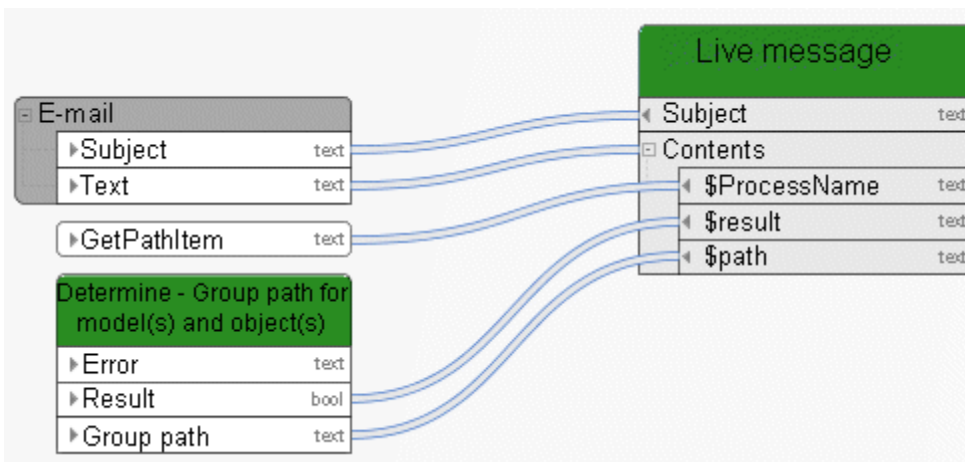























Figure 37: Determine - Group path for model(s) and object(s)

### 3.4.29 Retrieve - Lock status (model(s)/object(s))

This service determines the lock status for models and objects.

In/Out	Name	Details	Data type
	Database name	Name of the database in which the function of type <b>Automated task</b> is carried out.	<Text>
	Database language	Language the service uses for logging in to the database, e.g., <b>en</b> for English. You can specify this in more detail, e. g., <b>en</b> for English or <b>en_US</b> for English (United States). This is helpful, for example, if English (Australia) has been set in the database, but standard English (USA) has not been set.  If you want to add the country, you need to create a language constant and model it as a language in the data flow.	<Text> or <Language>
	User login	Login name of the user that is used for carrying out the <b>Automated task</b> function. If no user is defined, <b>arisservice</b> is used.	<Text>
	Password	Password of the user that is used for carrying out the <b>Automated task</b> function.	<Password>
	Selected items	Select the models or objects you want to check. The model check will return the status of the models, not the status of objects having occurrences in the models.	
	Identification	Either connect models, objects, or groups from the preselection of another object of type <b>Human task</b> , <b>Automated task</b> , or <b>Event (process instance started)</b> , or enter GUIDs and use the <b>Create collection</b> operator.	<Text collection>
	Error	If automation errors occur, context-specific error messages are displayed indicating, e.g., that ARIS Server is not available.	<Text>
	Result	Returns either TRUE or FALSE (Boolean), depending on whether or not the service was successfully performed.	<Boolean>
	No item locked	Returns TRUE (Boolean) if no item is locked. Returns FALSE (Boolean) if at least one item is	<Boolean>

In/O ut	Name	Details	Data type
		locked.	
	At least one item not locked	Returns TRUE (Boolean) if at least one item is not locked. Returns FALSE (Boolean) if all items are locked.	<Boolean>
	All items locked	Returns TRUE (Boolean) if all items are locked. Returns FALSE (Boolean) if at least one item is not locked.	<Boolean>
	No item open	Returns TRUE (Boolean) if no item is open. Returns FALSE (Boolean) if at least one item is locked.	<Boolean>
	At least one item open	Returns TRUE (Boolean) if at least one item is open. Returns FALSE (Boolean) if no item is locked.	<Boolean>
	All items open	Returns TRUE (Boolean) if all items are open. Returns FALSE (Boolean) if at least one item is not open.	<Boolean>
	Names of locked items	Returns the list of names of locked items.	<Text collection>
	GUIDs of locked items	Returns the list of GUIDs of locked items.	<Text collection>
	Item owner	The list of item owners having locked the items is output.	<Text collection>
	Names of open items	Returns the list of names of open items.	<Text collection>
	GUIDs of open items	Returns the list of GUIDs of open items.	<Text collection>
	Item owners of open items	Returns the list of item owners who opened the items.	<Text collection>
	Names of non-locked items	Returns the list of names of non-locked items.	<Text collection>

In/O ut	Name	Details	Data type
	GUIDs of non-locked items	Returns the list of GUIDs of non-locked items.	<Text collection>

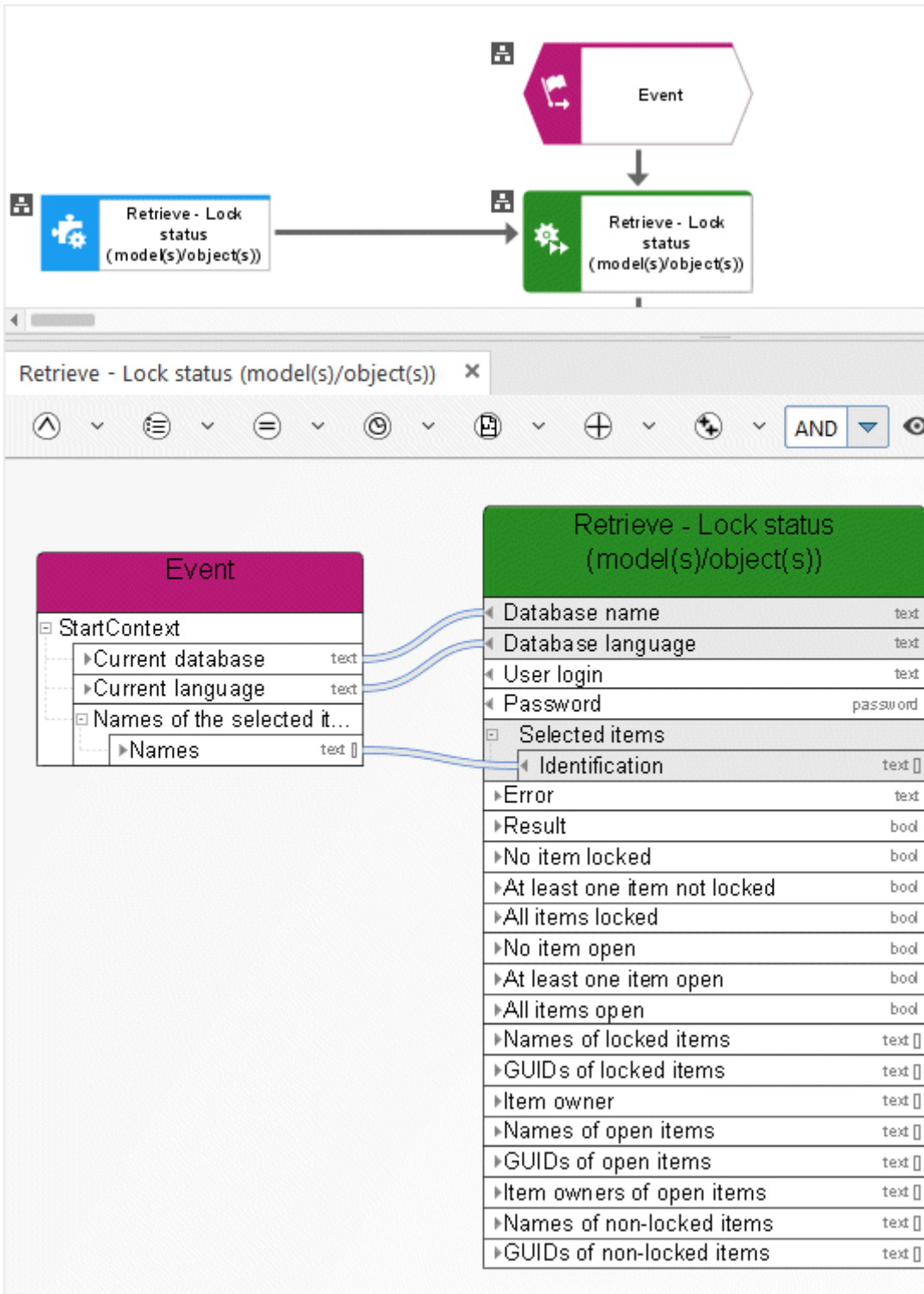











Figure 38: Check whether models or objects are locked

### 3.4.30 Retrieve - Model(s) and/or object(s) in scope

This service sorts input consisting of models and/or objects, and outputs two lists sorted by GUID, one for models and one for objects.

In/Output	Name	Details	Data type
	Database name	Name of the database in which the function of type <b>Automated task</b> is carried out.	<Text>
	Database language	Language the service uses for logging in to the database, e.g., <b>en</b> for English.  You can specify this in more detail, e. g., <b>en</b> for English or <b>en_US</b> for English (United States). This is helpful, for example, if English (Australia) has been set in the database, but standard English (USA) has not been set.  If you want to add the country, you need to create a language constant and model it as a language in the data flow.	<Text> or <Language>
	User login	Login name of the user that is used for carrying out the <b>Automated task</b> function. If no user is defined, <b>arisservice</b> is used.	<Text>
	Password	Password of the user that is used for carrying out the <b>Automated task</b> function.	<Password>
	Selected items	The models or objects in a scope.	
	Identification	An unsorted input of any objects and/or models.	<Complex>
	Error	If automation errors occur, context-specific error messages are displayed indicating, e.g., that ARIS Server is not available.	<Text>
	Result	Returns either TRUE or FALSE (Boolean), depending on whether or not the service was successfully performed.	<Boolean>
	ModelsGUIDs	List of models found in the input data sorted by GUID.	<Text>
	ObjectsGUIDs	List of objects found in the input data sorted by GUID.	<Text>



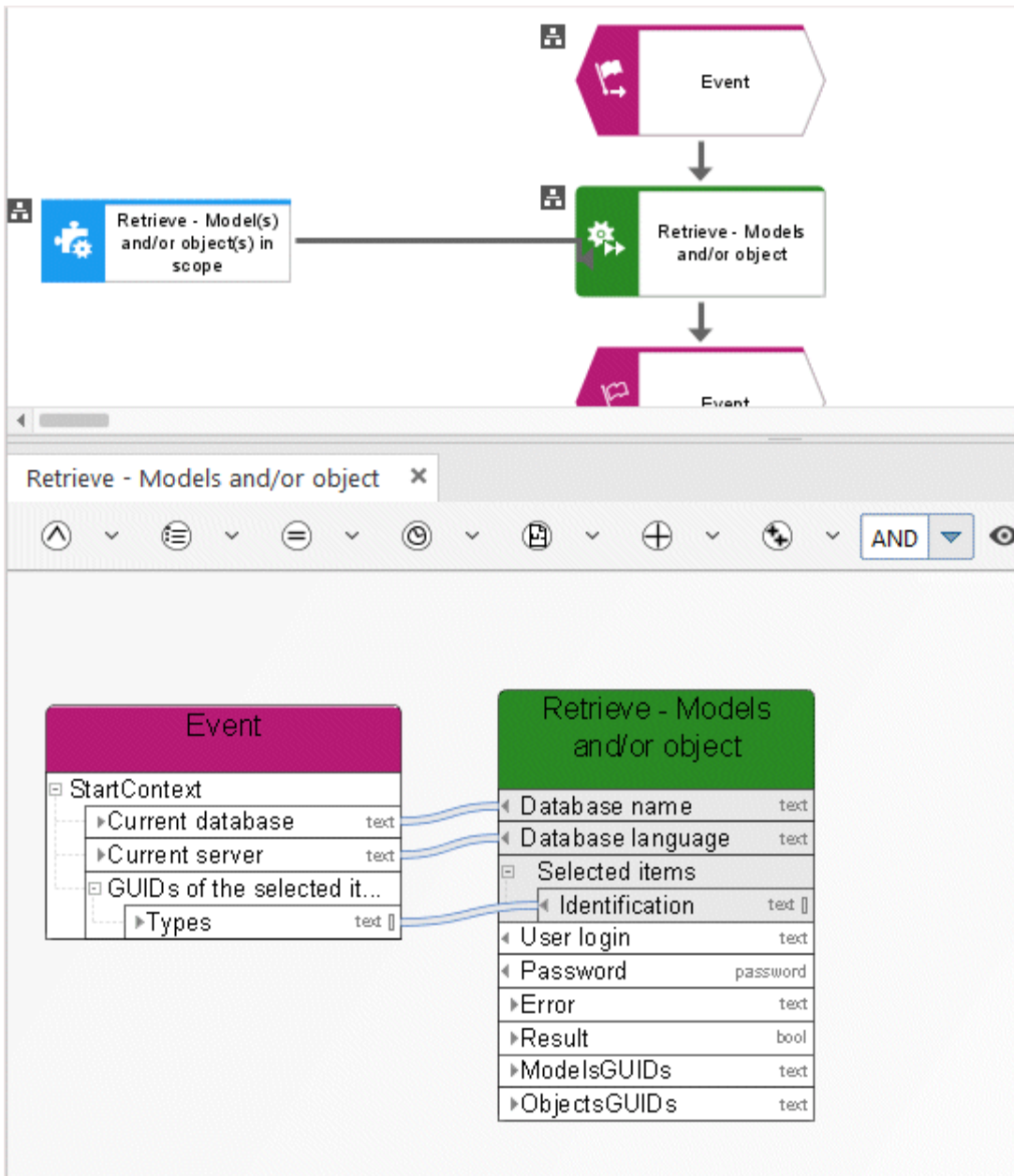













Figure 39: Determine - Models and/or objects

### 3.4.31 Retrieve - Multiple attributes from 1 item

This service determines multiple attributes (e. g., 'Model status', 'Version number', and 'Release') from exactly one item (model, object, or group).

In/Output	Name	Details	Data type
	Database name	Name of the database in which the function of type <b>Automated task</b> is carried out.	<Text>
	Database language	Language the service uses for logging in to the database, e.g., <b>en</b> for English. You can specify this in more detail, e. g., <b>en</b> for English or <b>en_US</b> for English (United States). This is helpful, for example, if English (Australia) has been set in the database, but standard English (USA) has not been set.  If you want to add the country, you need to create a language constant and model it as a language in the data flow.	<Text> or <Language>
	User login	Login name of the user that is used for carrying out the <b>Automated task</b> function. If no user is defined, <b>arisservice</b> is used.	<Text>
	Password	Password of the user that is used for carrying out the <b>Automated task</b> function.	<Password>
	Selected item	This service retrieves multiple attributes from exactly one model, one object, or one group, e.g., the attributes 'Description' and 'Author'. Either connect a model, object, or group from the preselection of another object of type <b>Human task</b> , <b>Automated task</b> , or <b>Event (process instance started)</b> , or enter the GUID.	<Text>
	Attributes to be retrieved	Retrieves the selected attributes (multiple attributes from exactly one item, e.g., the following attributes from a model: 'Model status', 'Version number', and 'Release').	
	Type	Either connect several attribute types from the preselection of another object of type <b>Human task</b> , <b>Automated task</b> , or <b>Event (process instance started)</b> , or enter the API names or GUIDs and use the <b>Create collection</b>	<Text collection>

In/Out	Name	Details	Data type
		operator.	
	Use default language	Specifies whether the default language for the database is to be used (TRUE) or not (FALSE).	<Boolean>
	Error	If automation errors occur, context-specific error messages are displayed indicating, e.g., that ARIS Server is not available.	<Text>
	Result	Returns either TRUE or FALSE (Boolean), depending on whether or not the service was successfully performed.	<Boolean>
	Attributes	Attributes are returned in a list with the corresponding values.	
	Attribute and value	The relevant attributes are returned in a list with the corresponding values.	
	Attribute type	The list of required attribute types is returned.	<Text>
	Attribute value	The list of attribute values is returned for the required attribute types.	<Text>

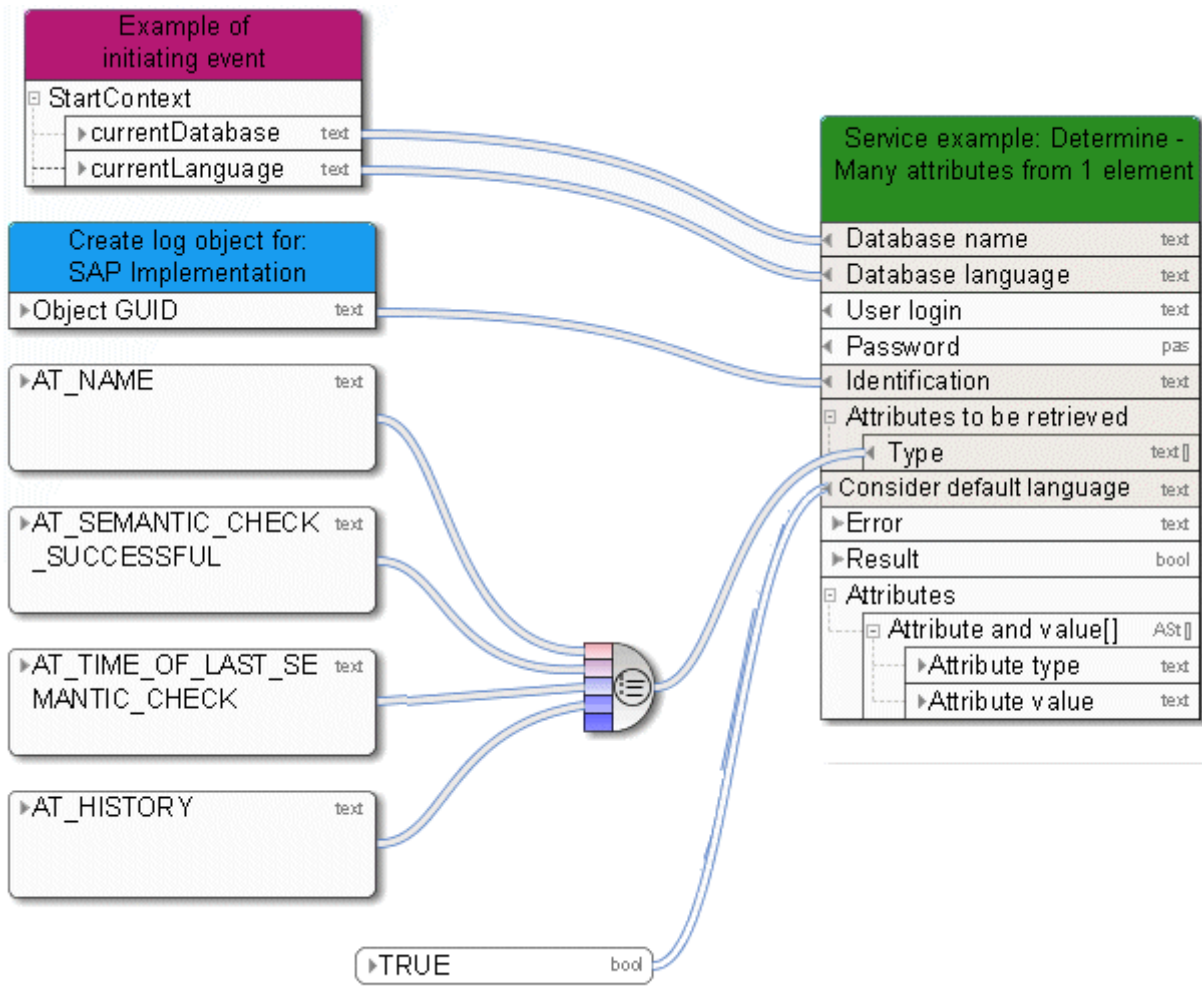









Figure 40: Determine multiple attributes from exactly one item

### 3.4.32 Retrieve - Versionable database

This service checks whether a database is versionable or not.

In/Out	Name	Details	Data type
	Database name	Name of the database in which the function of type <b>Automated task</b> is carried out.	<Text>
	Database language	<p>Language the service uses for logging in to the database, e.g., <b>en</b> for English. You can specify this in more detail, e. g., <b>en</b> for English or <b>en_US</b> for English (United States). This is helpful, for example, if English (Australia) has been set in the database, but standard English (USA) has not been set.</p> <p>If you want to add the country, you need to create a language constant and model it as a language in the data flow.</p> <p>You can specify this in more detail, e. g., <b>en</b> for English or <b>en_US</b> for English (United States). This is helpful, for example, if English (Australia) has been set in the database, but standard English (USA) has not been set.</p> <p>If you want to add the country, you need to create a language constant and model it as a language in the data flow.</p>	<Language>
	User login	Login name of the user that is used for carrying out the <b>Automated task</b> function. If no user is defined, <b>arisservice</b> is used.	<Text>
	Password	Password of the user that is used for carrying out the <b>Automated task</b> function.	<Password>
	Selected items	Whether or not the ARIS databases from which you want to retrieve the information is versionable.	
	Identification	GUIDs of the databases from which you want to retrieve the information whether or not the database is versionable.	<Text collection>
	Error	If automation errors occur, context-specific error messages are displayed indicating, e.g., that ARIS Server is not available.	<Text>
	IsVersionable	Returns either TRUE or FALSE (Boolean),	<Boolean>

In/Output	Name	Details	Data type
		depending on whether or not the service was successfully performed.	

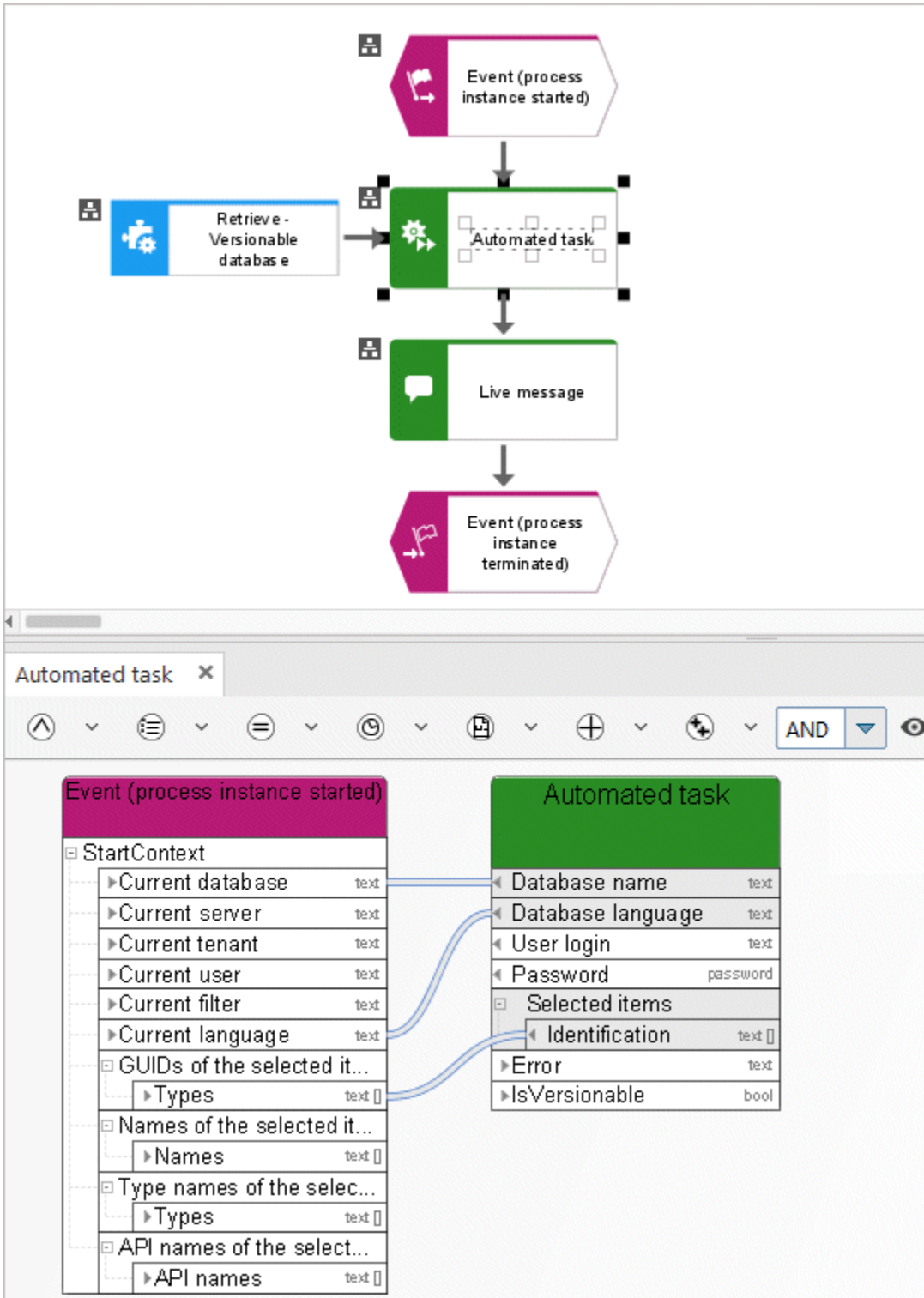











Figure 41: Retrieve - Versionable database

### 3.4.33 Unlock - Model(s)/Object(s)

This service unlocks models and/or objects. You can select the models or objects you want to unlock. You may also force unlocking (Administrator: Unlock).

In/Output	Name	Details	Data type
	Database name	Name of the database in which the function of type <b>Automated task</b> is carried out.	<Text>
	Database language	Language the service uses for logging in to the database, e.g., <b>en</b> for English. You can specify this in more detail, e. g., <b>en</b> for English or <b>en_US</b> for English (United States). This is helpful, for example, if English (Australia) has been set in the database, but standard English (USA) has not been set.  If you want to add the country, you need to create a language constant and model it as a language in the data flow.	<Text> or <Language>
	User login	Login name of the user that is used for carrying out the <b>Automated task</b> function. If no user is defined, <b>arisservice</b> is used.	<Text>
	Password	Password of the user that is used for carrying out the <b>Automated task</b> function.	<Password>
	Selected items	Select the models or objects you want to unlock.	
	Identification	Either connect models or objects from the preselection of another object of type <b>Human task</b> , <b>Automated task</b> , or <b>Event (process instance started)</b> , or enter GUIDs and use the <b>Create collection</b> operator.	<Text collection>
	Administrator: Unlock	Define the Boolean constant as TRUE to force unlocking. If no Boolean constant is defined, FALSE is used. If no specification is made, the default value FALSE is used.	<Boolean>
	Use current user for locking	If the current user is assigned to the corresponding field in the data flow via a connection, locking models or objects is performed as if the current user were doing it manually. This means that the personal	<Text>

In/O ut	Name	Details	Data type
	Database name	Name of the database in which the function of type <b>Automated task</b> is carried out.	<Text>
		privileges of the current user are taken into account, not the privileges of user <b>arisservice</b> actually performing the service.	
	Error	If automation errors occur, context-specific error messages are displayed indicating, e.g., that ARIS Server is not available.	<Text>
	Result	Returns either TRUE or FALSE (Boolean), depending on whether or not the service was successfully performed.	<Boolean>

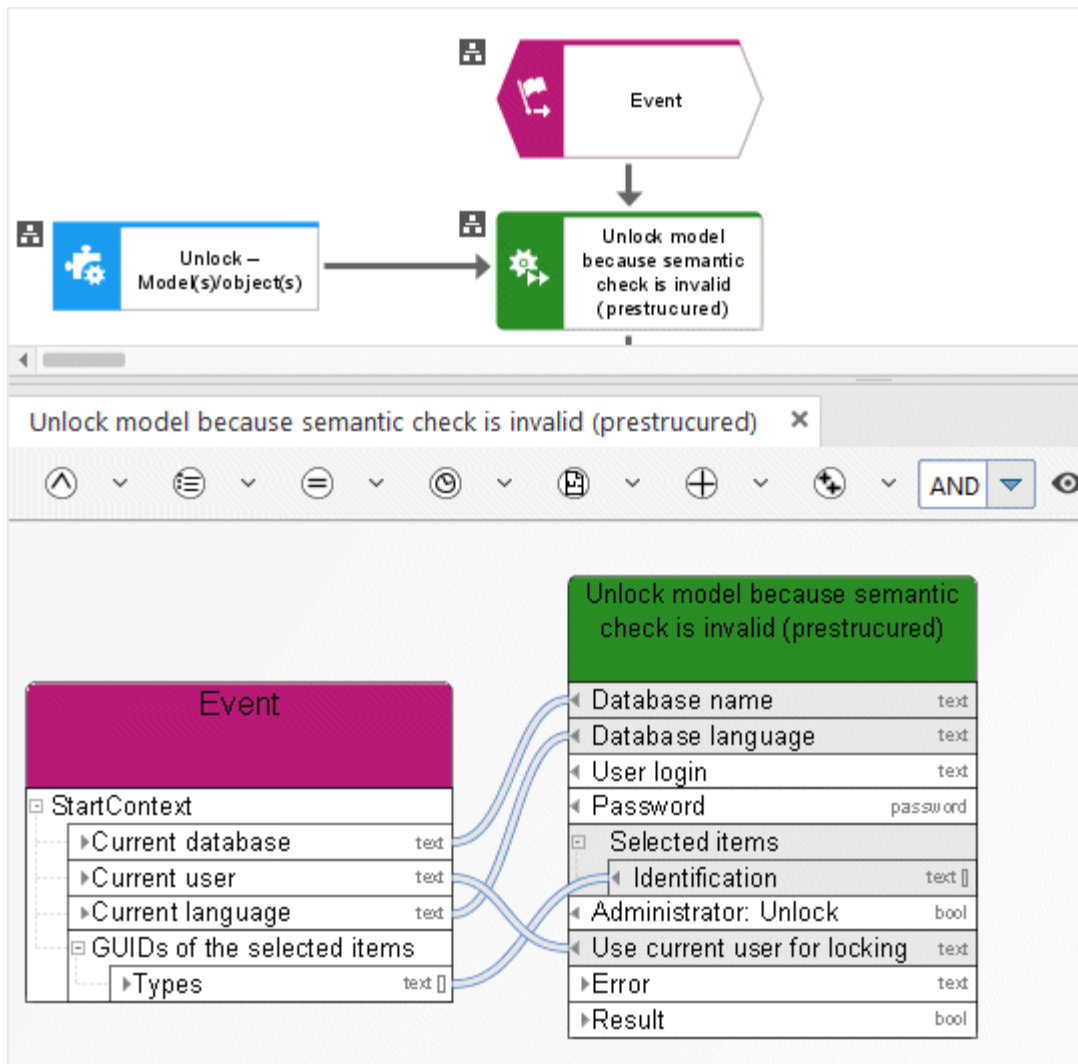









Figure 42: Unlock models and/or objects



### 3.4.34 Write - 1 attribute to multiple elements

This service specifies exactly one attribute (e. g., **Description**) for models, objects, or groups.

In/Out	Name	Details	Data type
	Database name	Name of the database in which the function of type <b>Automated task</b> is carried out.	<Text>
	Database language	Language the service uses for logging in to the database, e.g., <b>en</b> for English. You can specify this in more detail, e. g., <b>en</b> for English or <b>en_US</b> for English (United States). This is helpful, for example, if English (Australia) has been set in the database, but standard English (USA) has not been set.  If you want to add the country, you need to create a language constant and model it as a language in the data flow.	<Text> or <Language>
	User login	Login name of the user that is used for carrying out the <b>Automated task</b> function. If no user is defined, <b>arisservice</b> is used.	<Text>
	Password	Password of the user that is used for carrying out the <b>Automated task</b> function.	<Password>
	Selected items	Exactly one attribute is specified for multiple models, objects or groups, e.g., the <b>Description</b> attribute.	
	Identification	Either connect models, objects, or groups from the preselection of another object of type <b>Human task, Automated task, or Event (process instance started)</b> , or enter GUIDs and use the <b>Create collection</b> operator.	<Text collection>
	Attribute to be specified	Define the attributes you want to specify by using the API name, e.g.: AT_NAME for <b>Name</b> , or use the identifier if no API name exists.	<Text>
	Attribute value	Enter the value you want to specify for the attribute. If an empty string is sent as an input value, the attribute is cleared.	
	Value	Enter either a constant as a predefined value or use the data from another object of type <b>Human task, Automated task, or Event</b>	<Text collection>

In/O ut	Name	Details	Data type
		<b>(process instance started)</b> as input data.	
➔	Overwrite values	Define the Boolean constant as TRUE to delete existing attribute content and overwrite it with new content. Define the Boolean constant as FALSE to add new content and retain existing content (e. g., for the model attribute 'Change history'). If no specification is made, the default value FALSE is used.	<Boolean>
➡	Prepend values	Define a Boolean constant as TRUE to write a new value in front of existing attribute content.	<Boolean>
⬅	Error	If automation errors occur, context-specific error messages are displayed indicating, e.g., that ARIS Server is not available.	<Text>
⬅	Result	Returns either TRUE or FALSE (Boolean), depending on whether or not the service was successfully performed.	<Boolean>

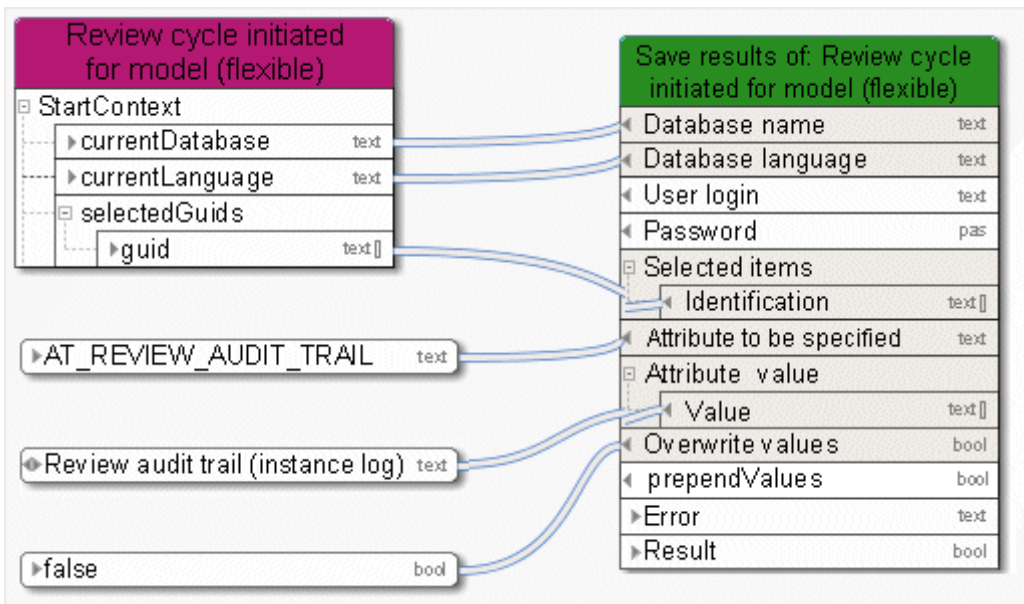











Figure 43: Specify exactly one attribute for multiple items

### 3.4.35 Write - Multiple attributes to 1 element

This service specifies multiple attributes (e. g., 'Model status', 'Version number', and 'Release') for exactly one item (a model, object, or group).

In/Output	Name	Details	Data type
	Database name	Name of the database in which the function of type <b>Automated task</b> is carried out.	<Text>
	Database language	Language the service uses for logging in to the database, e.g., <b>en</b> for English. You can specify this in more detail, e. g., <b>en</b> for English or <b>en_US</b> for English (United States). This is helpful, for example, if English (Australia) has been set in the database, but standard English (USA) has not been set.  If you want to add the country, you need to create a language constant and model it as a language in the data flow.	<Text> or <Language>
	User login	Login name of the user that is used for carrying out the <b>Automated task</b> function. If no user is defined, <b>arisservice</b> is used.	<Text>
	Password	Password of the user that is used for carrying out the <b>Automated task</b> function.	<Password>
	Selected item	Either connect models, objects, or groups from the preselection of another object of type <b>Human task</b> , <b>Automated task</b> , or <b>Event (process instance started)</b> , or enter GUIDs and use the <b>Create collection</b> operator.	<Text collection>
	Attributes to be specified	Is used to specify the selected attributes (multiple attributes for exactly one item, e.g., the following attributes for a model: 'Model status', 'Version number', and 'Release').	
	Type	Either connect several attribute types from the preselection of another object of type <b>Human task</b> , <b>Automated task</b> , or <b>Event (process instance started)</b> , or enter the API names or GUIDs and use the <b>Create collection</b> operator.	<Text collection>
	Attribute values	Define the values you want to specify for the attributes, e.g., a model status and model	

In/Out	Name	Details	Data type
		version number that were automatically defined by a preceding automated task.	
	Values	Either connect several attribute types from the preselection of another object of type <b>Human task</b> , <b>Automated task</b> , or <b>Event (process instance started)</b> , or enter the API names or GUIDs and use the <b>Create collection</b> operator. If an empty string is sent as an input value, the attribute(s) are cleared.	<Text collection>
	Overwrite values	Define the Boolean constant as TRUE to delete existing attribute content and overwrite it with new content. Define the Boolean constant as FALSE to add new content and retain existing content (e. g., for the model attribute 'Change history'). If no specification is made, the default value FALSE is used.	<Boolean>
	Error	If automation errors occur, context-specific error messages are displayed indicating, e.g., that ARIS Server is not available.	<Text>
	Result	Returns either TRUE or FALSE (Boolean), depending on whether or not the service was successfully performed.	<Boolean>

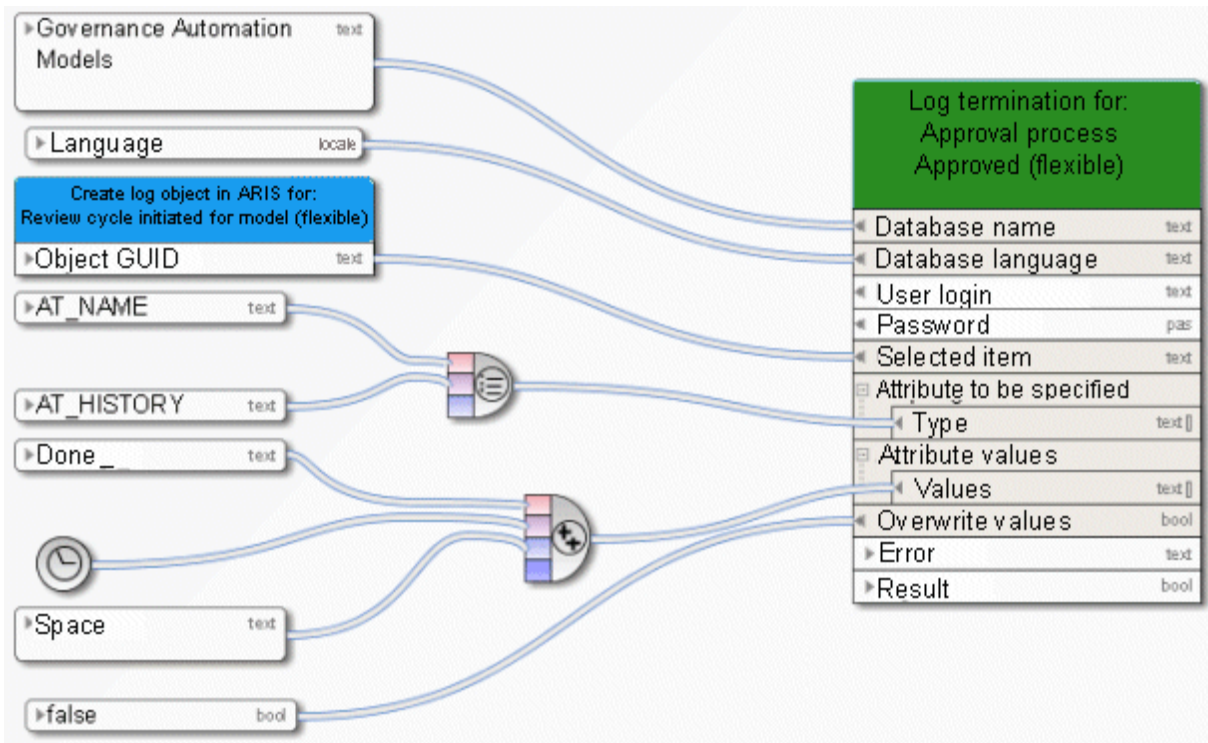







Figure 44: Specify multiple attributes for exactly one item

## 3.5 ARIS Connect Publishing Service

### 3.5.1 Add – Comment in Collaboration

This service adds a comment, e.g., to a model in ARIS Connect. Collaboration must be activated in ARIS Administration configuration. The service is always executed with the **system** user. The **system** user must have the ARIS Connect Viewer license privilege.

In/Out	Name	Details	Data type
	webIdentifier	ARIS Connect identifier or GUID in the format c.dbname.guid of the item which the comment belongs to in ARIS Connect. Mandatory field.	<Text>
	Tags	A list of tags for the comment.	<Text>
	Optional	Specifies whether posting the comment is optional. If the comment cannot be posted or Collaboration is unavailable, the service will fail and therefore also the process instance.	<Boolean>
	Comment	The comment to be posted. Posting is done by the <b>system</b> user. Mandatory field.	<Text>
	Return	The comment is posted in Collaboration. The posting is done as <b>system</b> user. When displaying the model or object, the comment is displayed in the Collaboration part of the screen.	<Boolean>

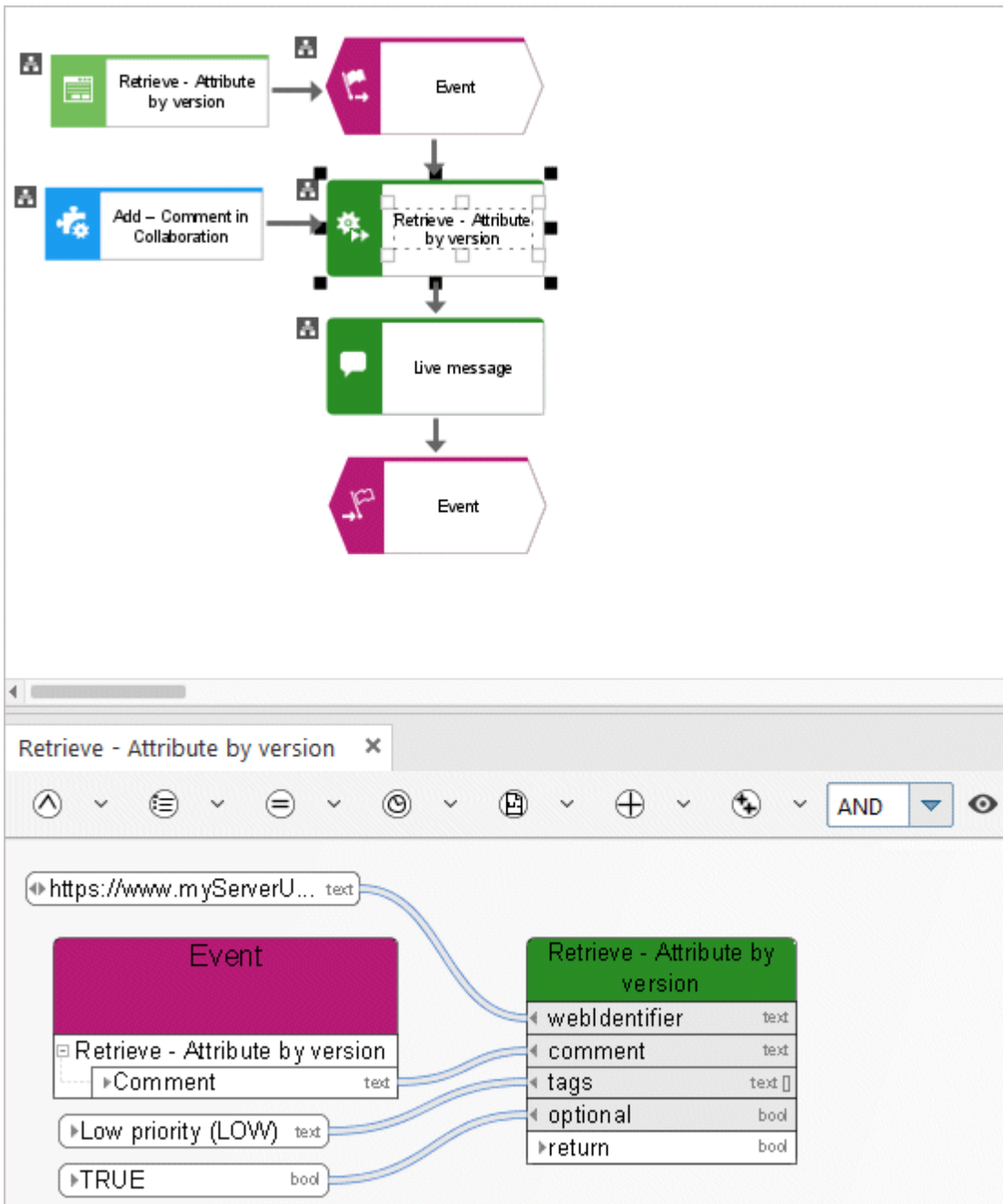







Figure 45: Add - Comment in Collaboration

### 3.5.2 Retrieve - Link in ARIS Connect

The service provides a list of links to models in ARIS Connect in order to make them available to users that do not work with ARIS Architect, for example.

In/Output	Name	Details	Data type
	Database name	Name of the current database	<Text>
	Database version	Version of the database, for example, returned by the service <b>Create - Version</b> (page 70).	<Decimal number>
Selected items		Select the models to which a link is to be created in ARIS Connect.	
	Identifier	GUID of the models to which a link is to be retrieved in ARIS Connect.	<Text>
	itemTypes	The item types of the items selected.	<Text>
	return	A link list is provided for all relevant models. Exactly one link is allowed for each link field in a dialog. The service provides a list of links if more than one link is specified for accessing a model. In the data flow of a dialog, model every single link by using an operator determining the selection.	<Text collection>



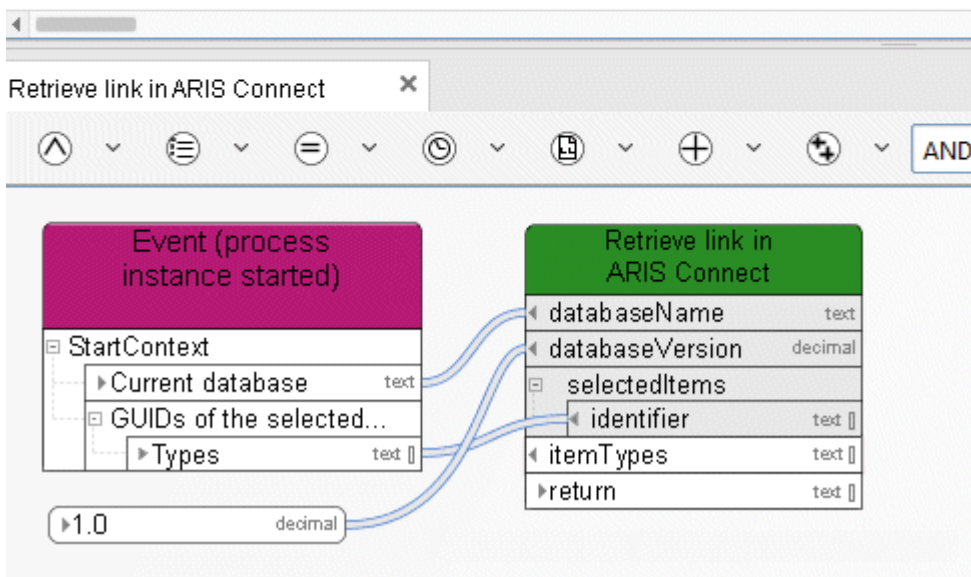
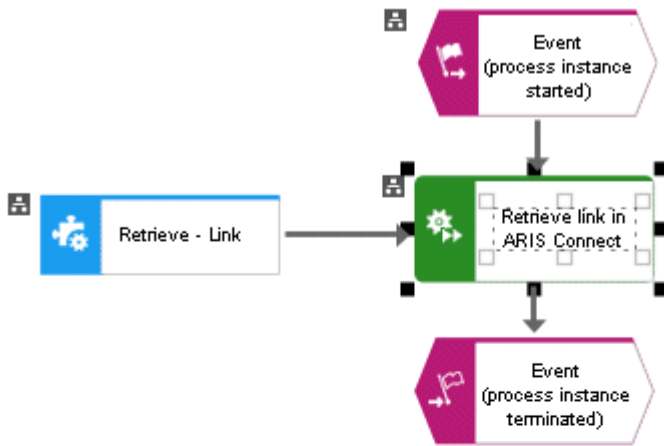











Figure 46: Determine - Link

## 3.6 ARIS document storage

The use of document-related services is tested and released for documents which are stored in ARIS document storage only and not for external document managements systems like Microsoft® SharePoint.

### 3.6.1 Create - Document

This service creates a new document in ARIS document storage.

In/Output	Name	Details	Data type
	ADS user	Optional. If not specified, the <b>arisservice</b> user is used, which is our recommendation.	<Text>
	ADS password	Optional. If not specified, the <b>arisservice</b> user password is used.	<Password>
	Target folder	Folder of the storage location in ARIS document storage to which the document should be uploaded, mandatory field. Example: <b>PERMANENT_PORTAL_default/root/My documents/</b>	<Folder>
	Title	Document title.	<Text>
	Description	Document description.	<Text>
	Status	Document status. The following values shown in uppercase letters are possible: <ul style="list-style-type: none"> <li>▪ APPROVED (Approved)</li> <li>▪ IN_PROGRESS (In process)</li> <li>▪ ON_APPROVAL (To be approved)</li> <li>▪ REJECTED (Rejected)</li> </ul>	<Text>
	Version	Document version.	<Text>
	Tags	Tags identifying the document.	<Text collection>
	File URL	URL to the physical location of the file on ARIS Server, mandatory field. Example: <b>D:\temp\document.doc.</b>	<Text>
	Documents	Document created (<Document> type)	<Document collection>

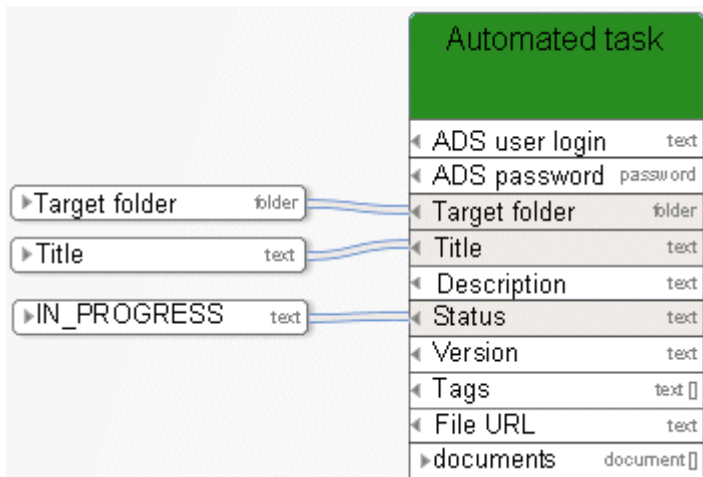





Figure 47: Create document

### 3.6.2 Create - Folder

This service creates a new folder in ARIS document storage with the given name.

In/Out	Name	Details	Data type
	ADS user login	Optional. If not specified, the <b>arisservice</b> user is used, which is our recommendation.	<Text>
	ADS password	Optional. If not specified, the <b>arisservice</b> user password is used.	<Password>
	Folder name and path	Mandatory input. Name of the folder to be created, e. g., <b>PERMANENT_PORTAL_default/root/My documents/</b> .	<Folder>
	Folder	Returns the newly created folder.	<Folder>

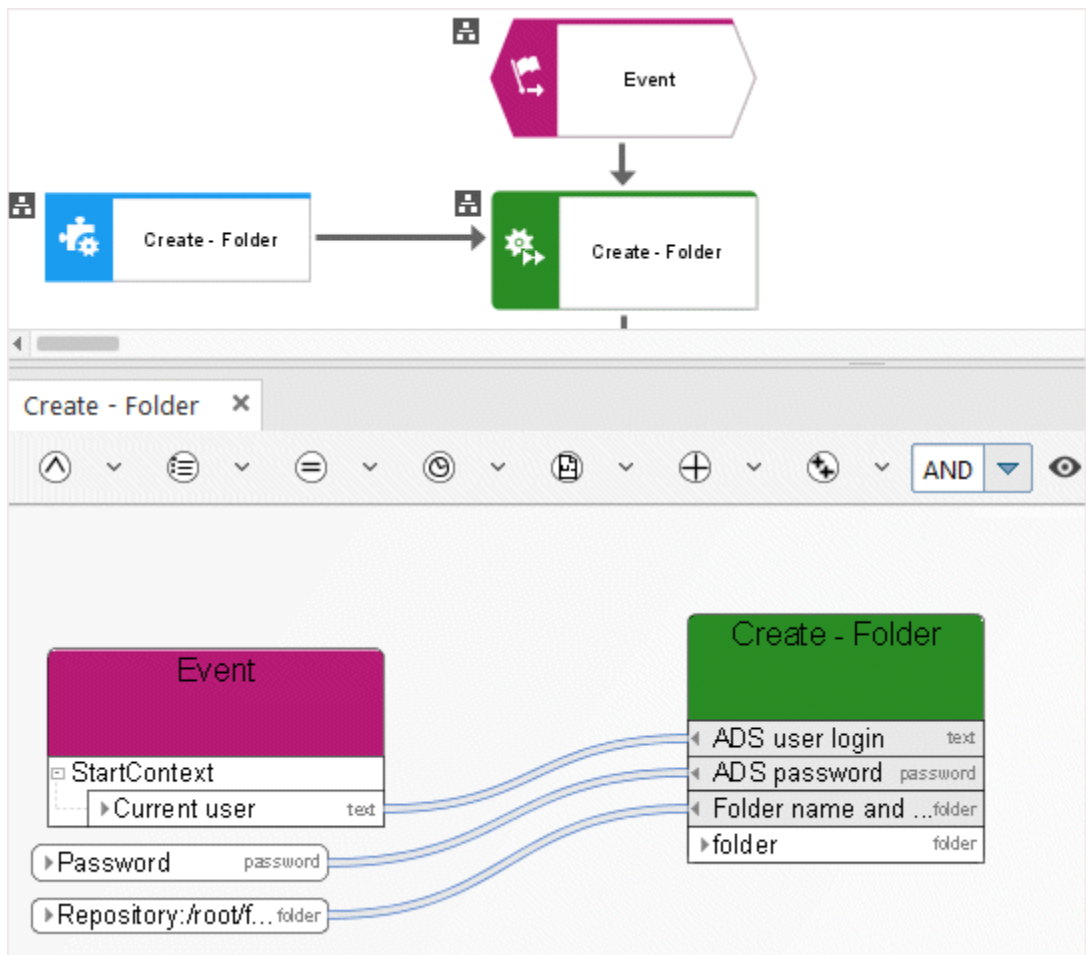

Figure 48: Create folder

### 3.6.3 Delete Document(s)

This service deletes documents from ARIS document storage.

In/O ut	Name	Details	Data type
➔	ADS user	Optional. If not specified, the <b>arisservice</b> user is used, which is our recommendation.	<Text>
➔	ADS password	Optional. If not specified, the <b>arisservice</b> user password is used.	<Password>
➔	Documents	List of documents to be deleted, mandatory field.	<Document collection>

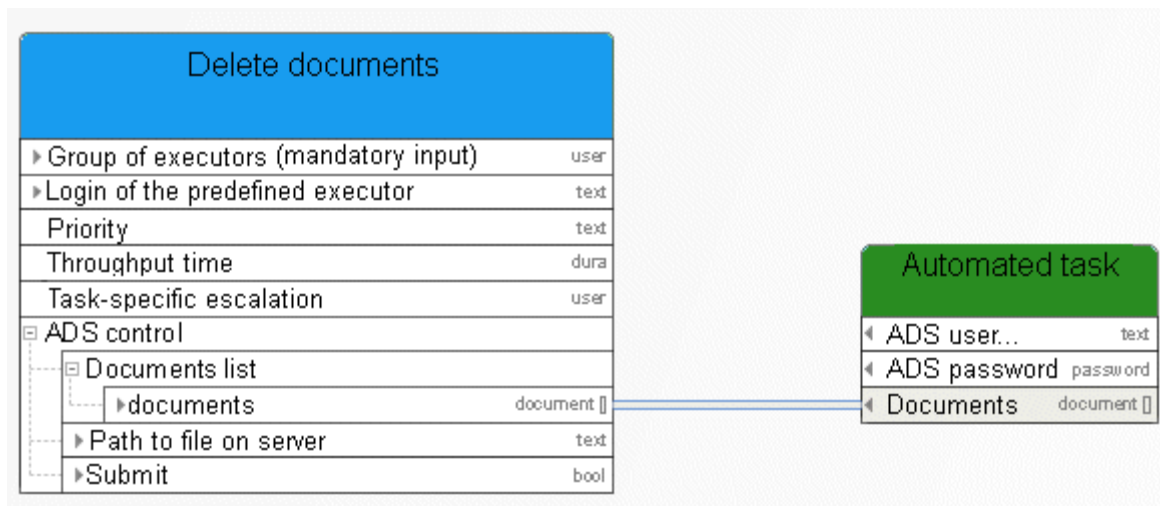

Figure 49: Delete document

### 3.6.4 Download - Document

This service downloads a document from ARIS document storage.

In/O ut	Name	Details	Data type
➔	ADS user	Optional. If not specified, the <b>arisservice</b> user is used, which is our recommendation.	<Text>
➔	ADS password	Optional. If not specified, the <b>arisservice</b> user password is used.	<Password>
➔	DocumentID	Documents to be downloaded, mandatory field.	<Document>
➔	targetPath	URL to the physical location of the file on ARIS Server, mandatory field. Example: <b>D:\temp\document.doc.</b>	<Text>
➔	OverwriteExisting	Can assume the values TRUE (overwrite) or FALSE (do not overwrite)	<Boolean>
⬅	documentContent	Document content	<Text>

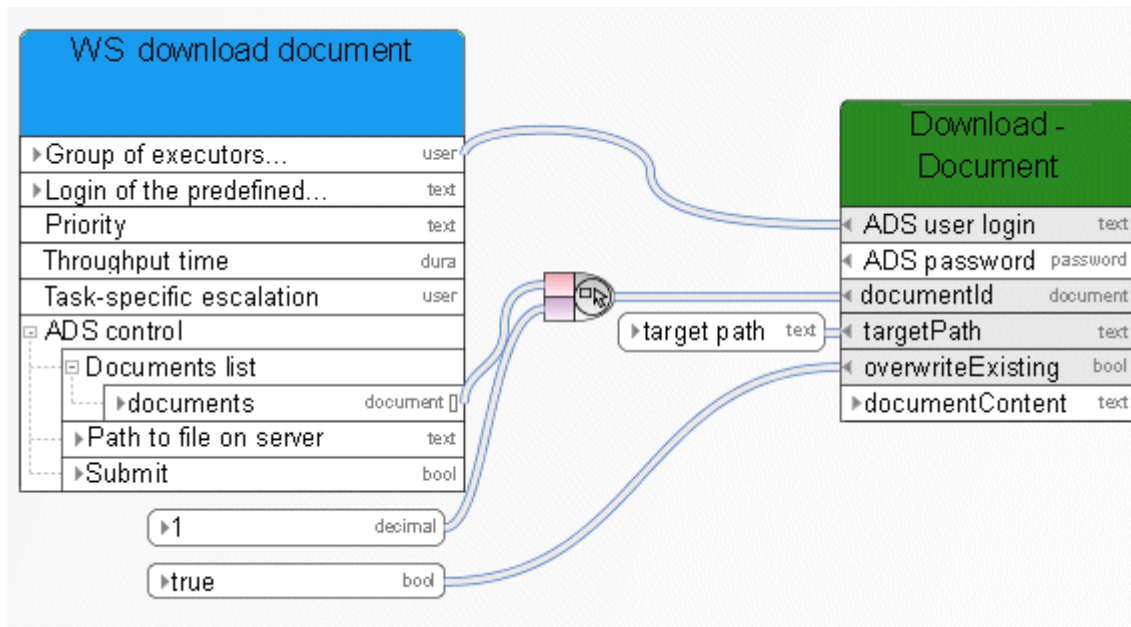

Figure 50: Download document

### 3.6.5 Lock - Document(s)

This service locks documents in ARIS document storage for editing by other users.

In/O ut	Name	Details	Data type
➔	ADS user	Optional. If not specified, the <b>arisservice</b> user is used, which is our recommendation.	<Text>
➔	ADS password	Optional. If not specified, the <b>arisservice</b> user password is used.	<Password >
➔	Documents	List of documents to be locked, mandatory field.	<Docume nt collection>
➔	Successful	Returns information on whether all documents were locked.	<Boolean >

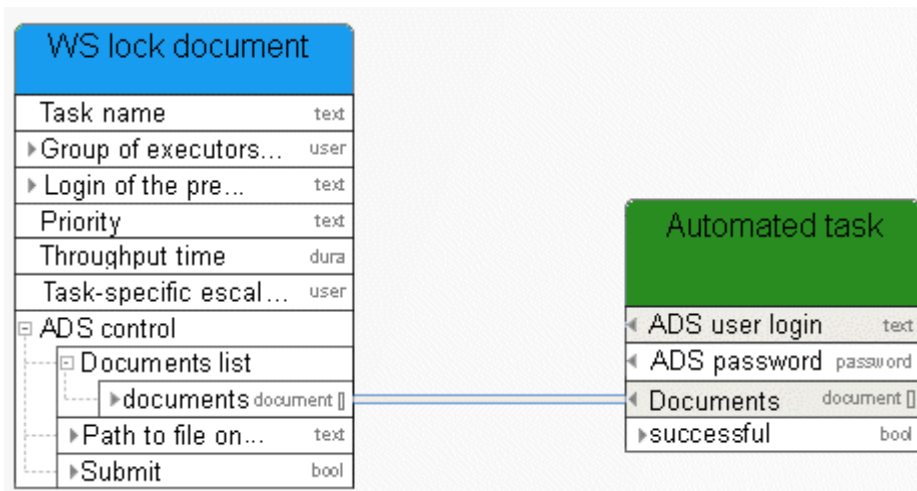

Figure 51: Lock documents

### 3.6.6 Move - Document(s)

You can use this service to either transfer a temporary document into ARIS document storage or to move a permanently saved document to another folder within ARIS document storage.

In/O ut	Name	Details	Data type
➔	ADS user	Optional. If not specified, the <b>arisservice</b> user is used, which is our recommendation.	<Text>
➔	ADS password	Optional. If not specified, the <b>arisservice</b> user password is used.	<Password>
➔	Documents	List of documents to be moved, mandatory field.	<Document collection>
➔	Target folder	Target folder into which the documents are to be moved, mandatory field.	<Text> or <Folder>
➞	Moved documents	List of documents (Document data type)	<Document collection>

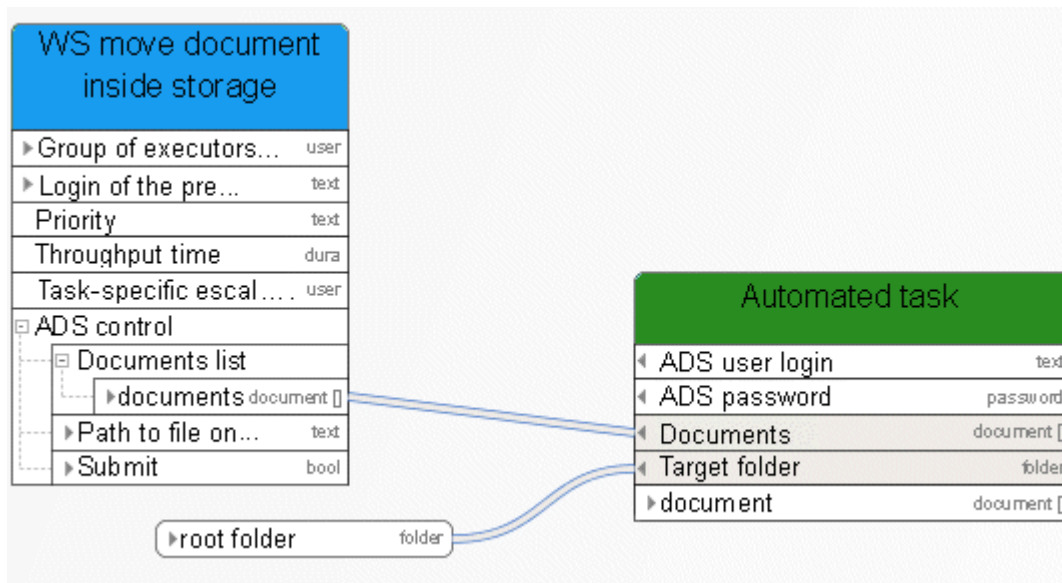





Figure 52: Move documents



### 3.6.7 Retrieve - Document(s) by ID

This service retrieves documents in ARIS document storage by ID.

In/Out	Name	Details	Data type
	ARIS document storage user	Optional. If not specified, the <b>arisservice</b> user is used, which is our recommendation.	<Text>
	ARIS document storage password	Optional. If not specified, the <b>arisservice</b> user password is used.	<Password>
	Documents	Select the relevant documents.	
	Value	The IDs of the documents in ARIS document storage.	<Text collection>
	Documents	Document created (<Document> type)	<Document collection>

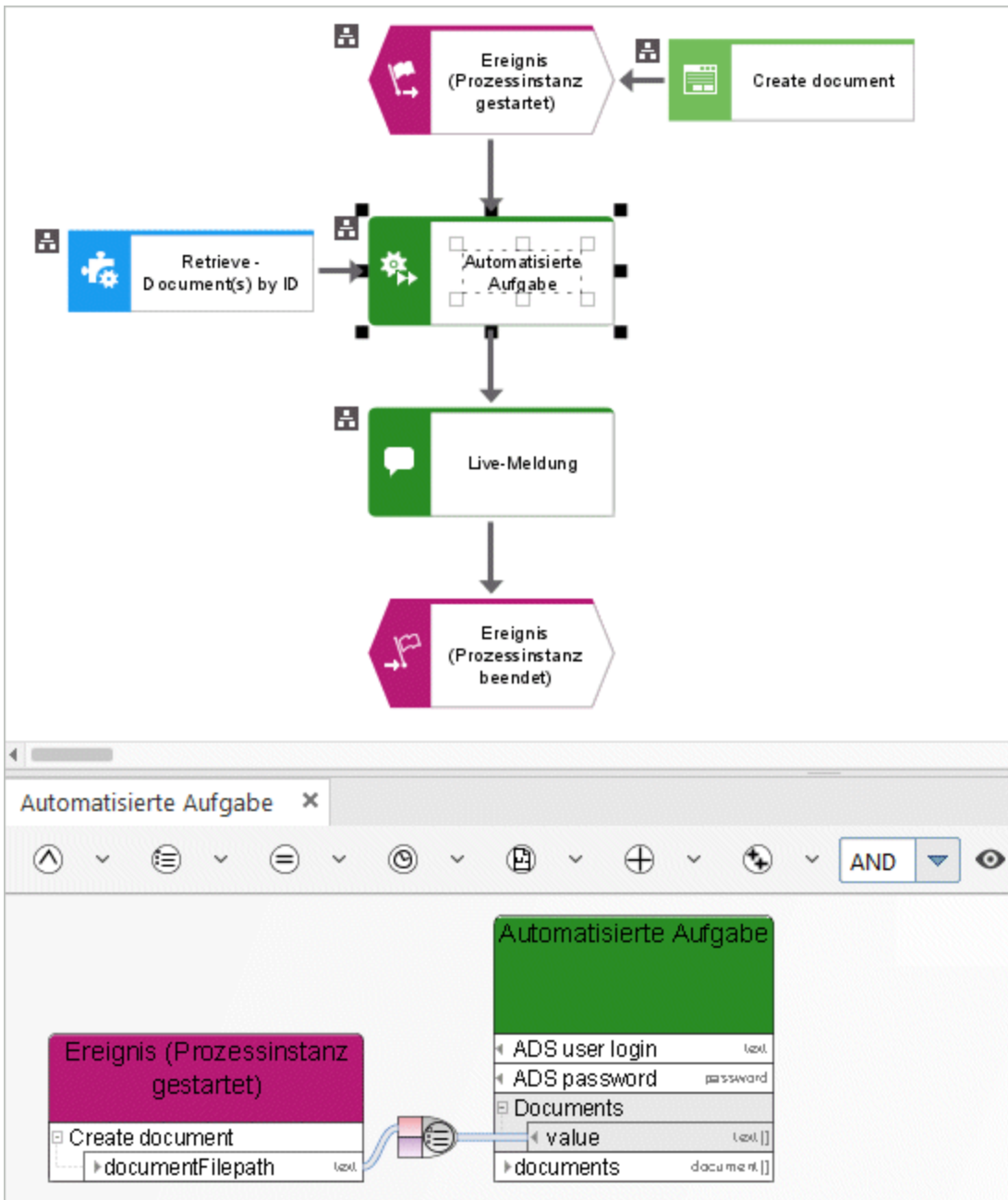





Figure 53: Retrieve - Document(s) by ID

### 3.6.8 Retrieve - Document(s) by link

This service returns a document that has been retrieved via its HTTP link.

In/Out	Name	Details	Data type
	ARIS document storage user	Optional. If not specified, the <b>arisservice</b> user is used, which is our recommendation.	<Text>
	ARIS document storage password	Optional. If not specified, the <b>arisservice</b> user password is used.	<Password>
	documentLink	HTTP link to document storage location in ARIS document storage; is a mandatory field; is modeled in the data flow.	<Text collection>
	Document	Document created (<Document> type)	<Document collection>

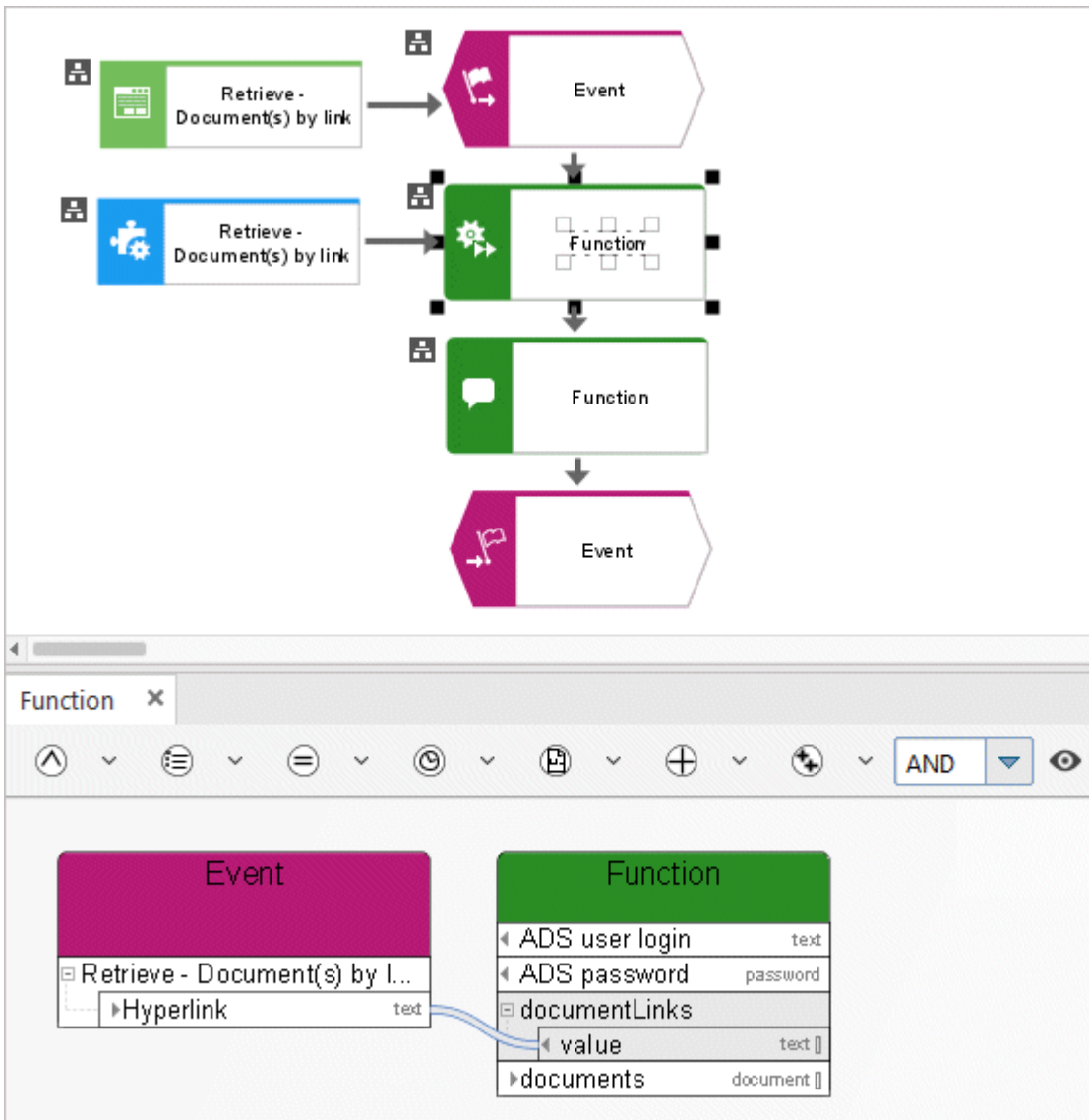

Figure 54: Retrieve - Document(s) by link

### 3.6.9 Unlock - Document(s)

This service unlocks documents in ARIS document storage.

In/O ut	Name	Details	Data type
➔	ADS user	Optional. If not specified, the <b>arisservice</b> user is used, which is our recommendation.	<Text>
➔	ADS password	Optional. If not specified, the <b>arisservice</b> user password is used.	<Password>
➔	Documents	List of documents to be unlocked, mandatory field.	<Document collection>
⬅	Successful	Returns information on whether all documents were unlocked.	<Boolean>

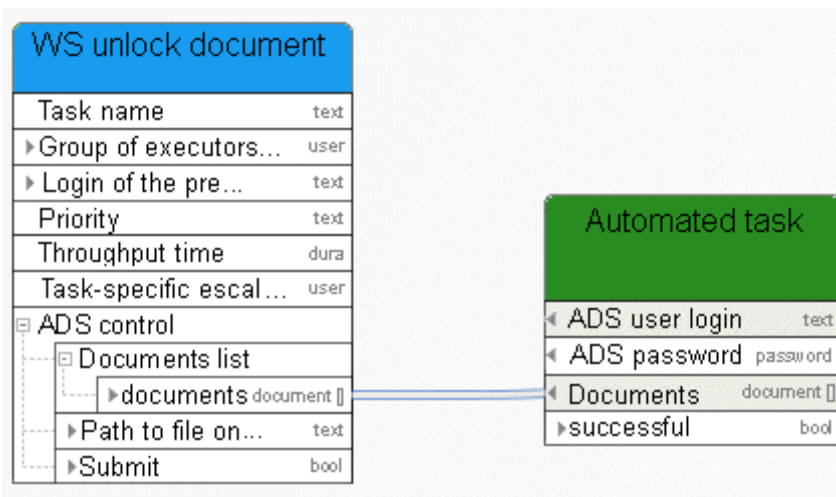

Figure 55: Unlock documents

### 3.6.10 Update - Document(s)

This service is performed on the server side. The document with the new content that is to update the document in ARIS document storage must exist on ARIS Server. Typically, this is the case with report results or log files. Usually, the service is called by an object of the **Automated task** type.

In/O ut	Name	Details	Data type
➔	ARIS document storage user	Optional. If not specified, the <b>arisservice</b> user is used, which is our recommendation.	<Text>
➔	ARIS document storage password	Optional. If not specified, the <b>arisservice</b> user password is used.	<Password>
➔	Documents	List of documents that are stored in ARIS document storage and the content of which is to be updated, mandatory field.	<Document collection>
➔	File URLs	URL to the physical location of the file on ARIS Server, mandatory field. Example: <b>D:\temp\document.doc</b> .	<Text collection>
➔	Updated documents	List of updated documents	<Document collection>

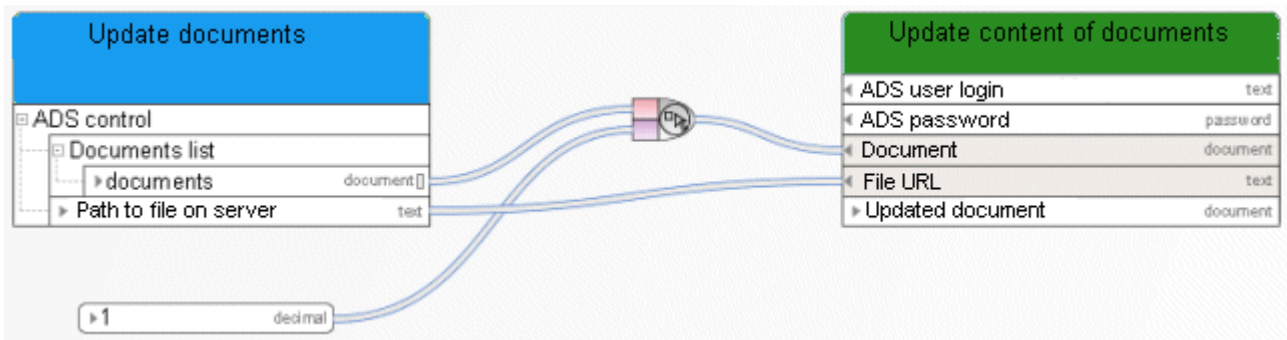

Figure 56: Update documents

### 3.6.11 Update - Metadata of 1 document

This service updates the metadata of a document.

In/O ut	Name	Details	Data type
➔	ADS user	Optional. If not specified, the <b>arisservice</b> user is used, which is our recommendation.	<Text>
➔	ADS password	Optional. If not specified, the <b>arisservice</b> user password is used.	<Password>
➔	Document	Document whose metadata is to be updated, mandatory field.	<Document>
➔	Keys	List of metadata keys to be updated, mandatory field.	<Text collection>
➔	Values	List of metadata values to be updated, mandatory field.	<Text collection>
➔	Updated document	Document whose metadata was updated. If the document name is changed during the update, the document name prior to the update is returned.	<Document>

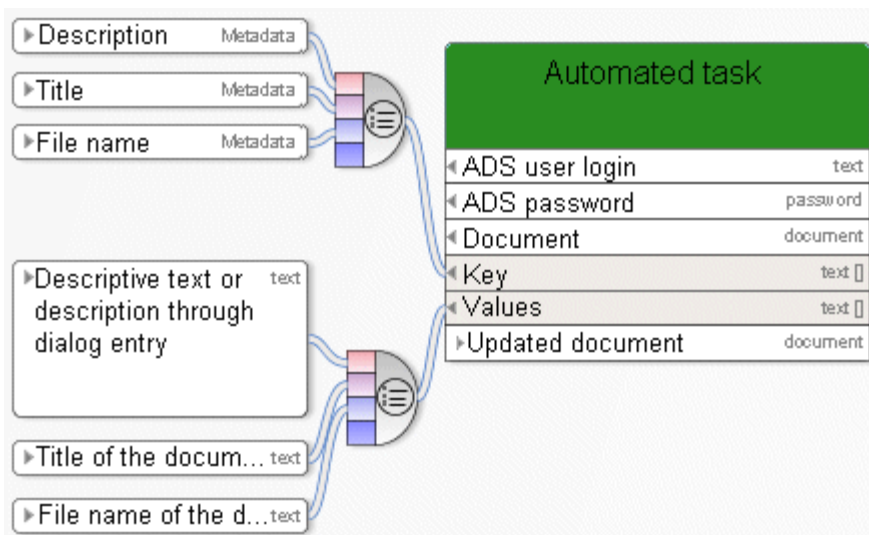

Figure 57: Update metadata of a document

### 3.6.12 Update - Metadata of multiple documents

This service updates a metadata key and value pair for multiple documents.

In/O ut	Name	Details	Data type
➔	ADS user	Optional. If not specified, the <b>arisservice</b> user is used, which is our recommendation.	<Text>
➔	ADS password	Optional. If not specified, the <b>arisservice</b> user password is used.	<Password>
➔	Documents	List of documents whose metadata is to be updated, mandatory field.	<Document collection>
➔	Key	Metadata key that is to be updated for all documents in the document list, mandatory field.	<Text>
➔	Value	Metadata value that is to be updated for all documents in the document list, mandatory field.	<Text>
⬅	Updated documents	List of documents for which a metadata key/value pair was updated. If document names are changed during the update, the document names prior to the update are returned.	<Document collection>

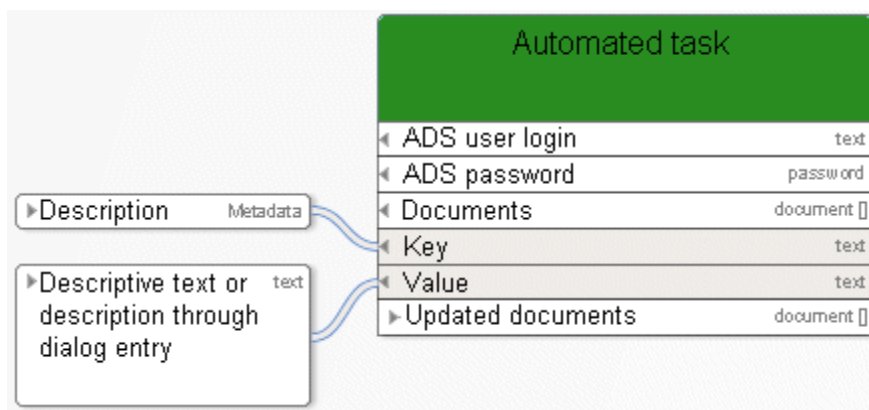

Figure 58: Update metadata of multiple documents



### 3.7 Process Governance Service

#### 3.7.1 Retrieve - Process instance ID

This service retrieves the ID of the process instance of the running process.

In/Output	Name	Details	Data type
	Instance ID	ID of the process instance of the running process.	<Text>

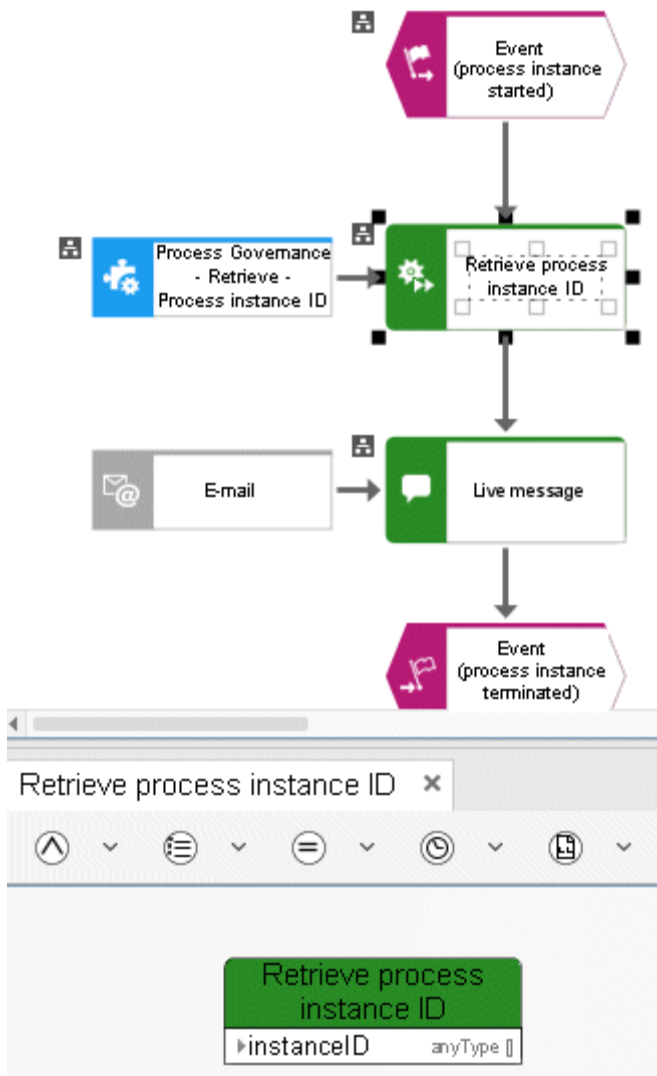

Figure 59: Process Governance - Determine - Process instance ID

### 3.8 User management

#### 3.8.1 Assign - Privilege to user

This service assigns function privileges to users.

In/Output	Name	Details	Data type
	Privilege	The function privilege to be assigned to the user, e. g., Process Governance administrator.	<Text>
	User	User who is to be assigned a function privilege.	<User>
	Result	Returns either TRUE or FALSE (Boolean), depending on whether or not the service was successfully performed.	<Boolean>

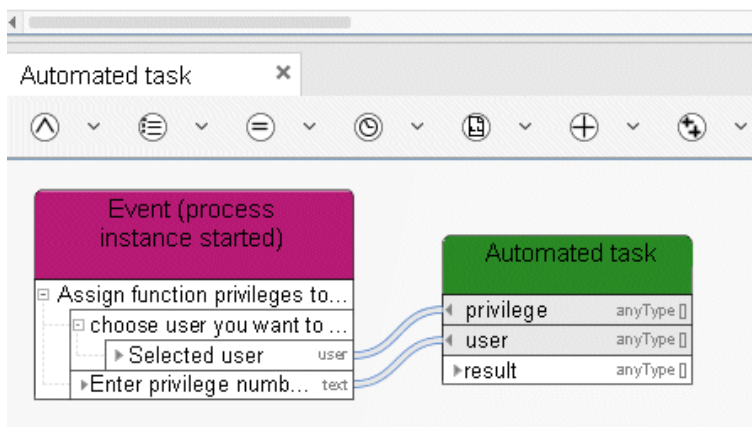
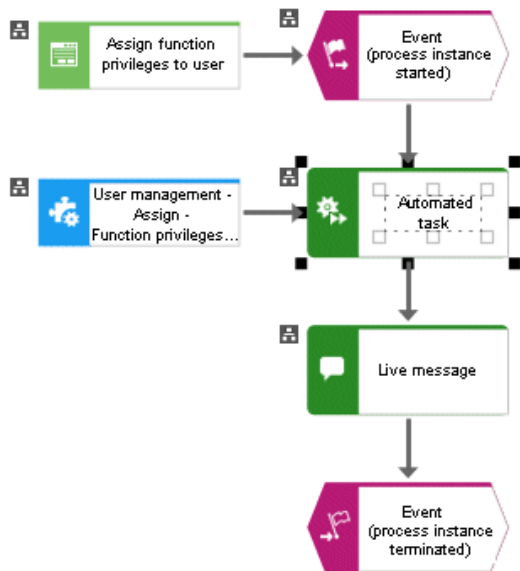





Figure 60: User management - Assign - Function privileges to user

### 3.8.2 Assign - Privilege to user group

This service assigns function privileges to user groups.

In/Out	Name	Details	Data type
	Privilege	The function privilege to be assigned to the user, e. g., Process Governance administrator.	<Text>
	User group	User group who is to be assigned a function privilege.	<User collection>
	Result	Returns either TRUE or FALSE (Boolean), depending on whether or not the service was successfully performed.	<Boolean>

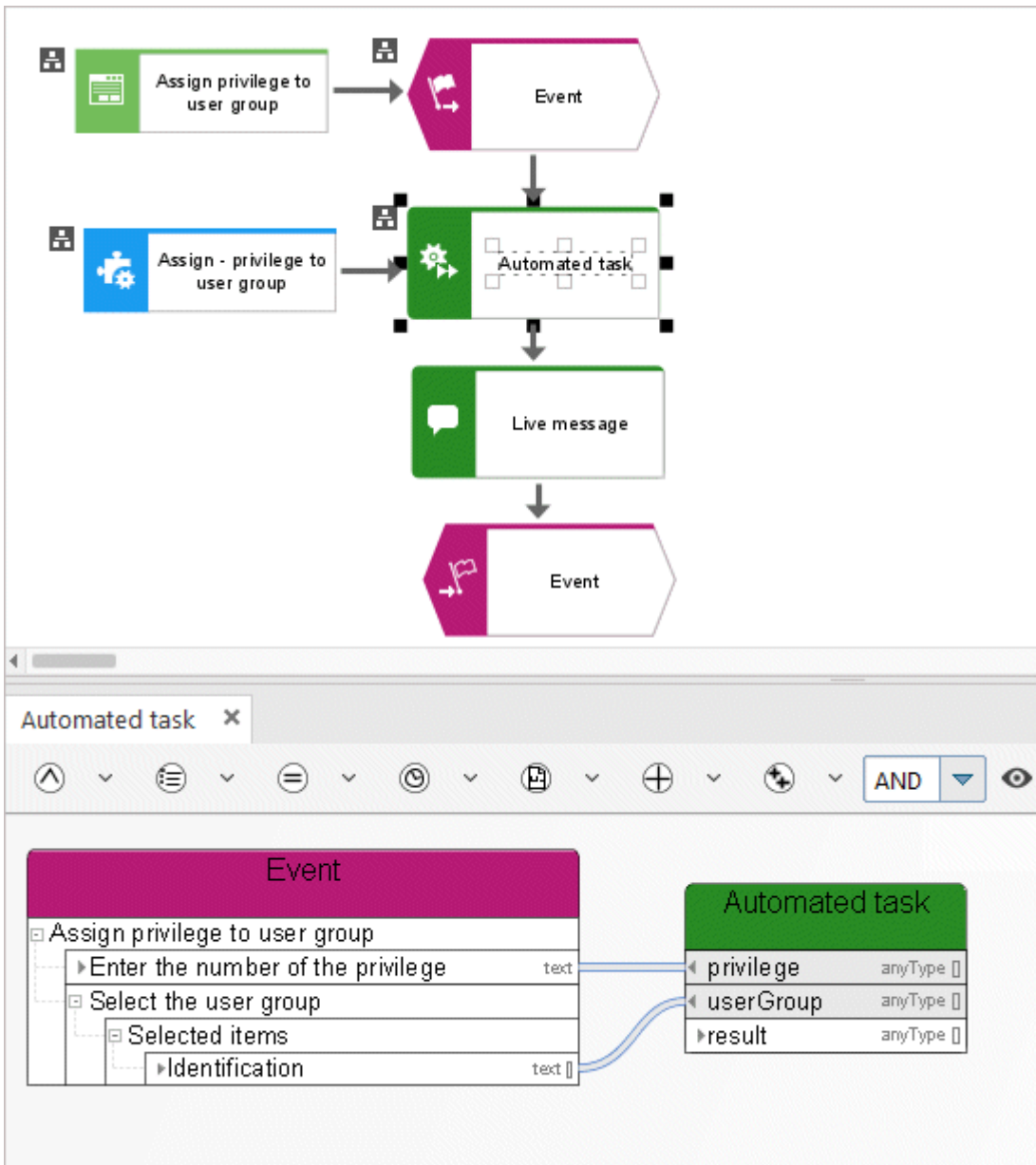





Figure 61: Assign - privilege to user group

### 3.8.3 Assign - Product license to user

This service assigns a license to a user.

In/Out	Name	Details	Data type
	Product code	Specific product license to be assigned to the user, e. g., YBU for ARIS Publisher.	<Text>
	User group	User who is to be assigned a specific license.	<User>
	Result	Returns either TRUE or FALSE (Boolean), depending on whether or not the service was successfully performed.	<Boolean>

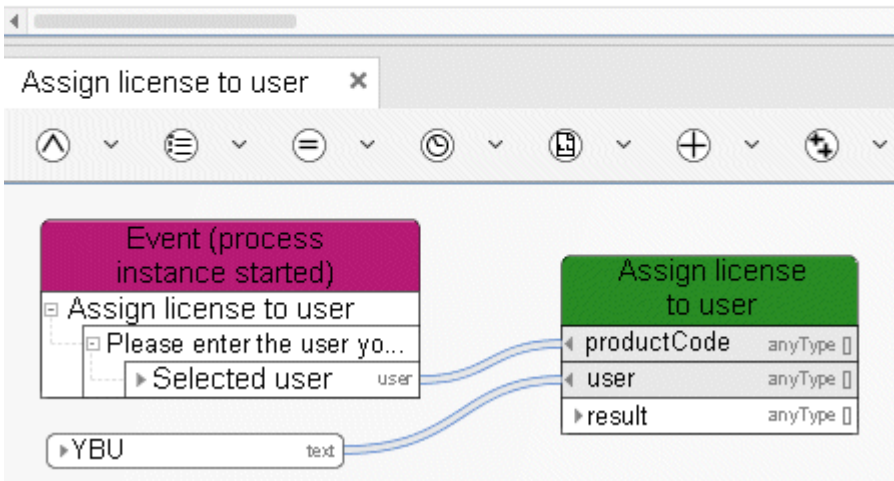
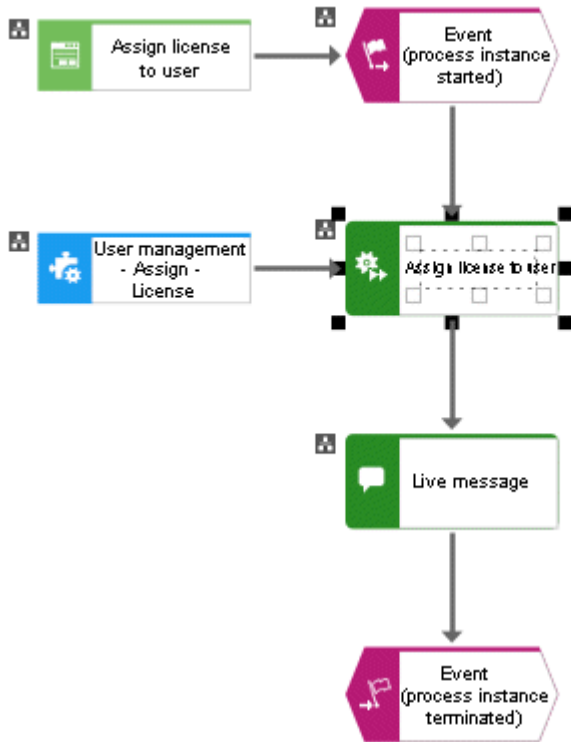





Figure 62: User management - Assign - License

### 3.8.4 Assign - Product license to user group

This service assigns a license to a user group.

In/Out	Name	Details	Data type
	Product code	Specific product license to be assigned to the user group, e. g., YBU for ARIS Publisher.	<Text>
	Group	User group who is to be assigned a specific license.	<User group>
	Result	Returns either TRUE or FALSE (Boolean), depending on whether or not the service was successfully performed.	<Boolean>

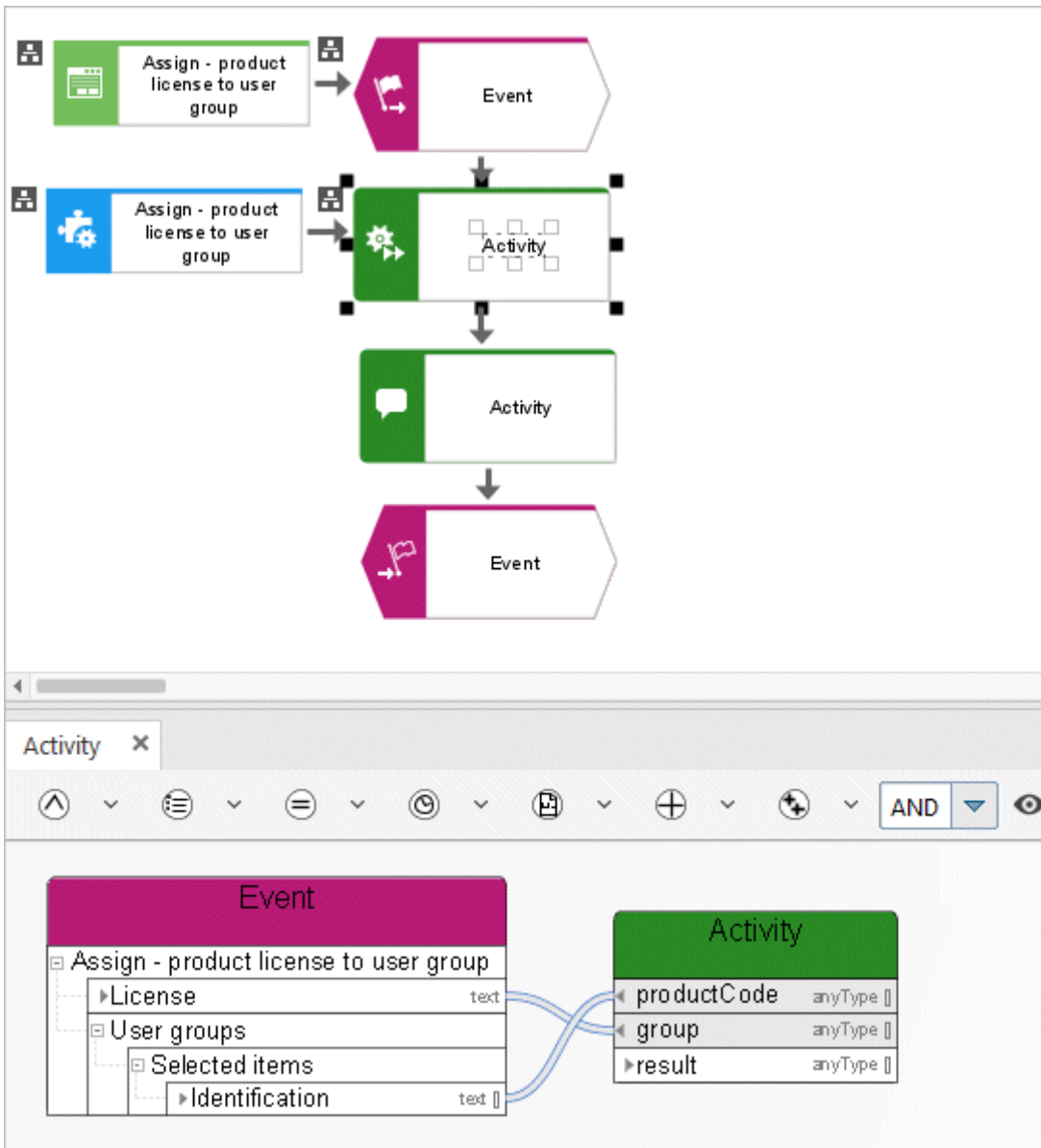





Figure 63: Assign - product license to user group



### 3.8.5 Assign - User to group

This service associates a user with a specific user group in the user management of Administration.

In/Output	Name	Details	Data type
	Group	User group with which a user is to be associated.	<User> or <text>
	User	User to be associated with a specific user group.	<User> or <text>
	Result	Returns either TRUE or FALSE (Boolean), depending on whether or not the service was successfully performed.	<Boolean>

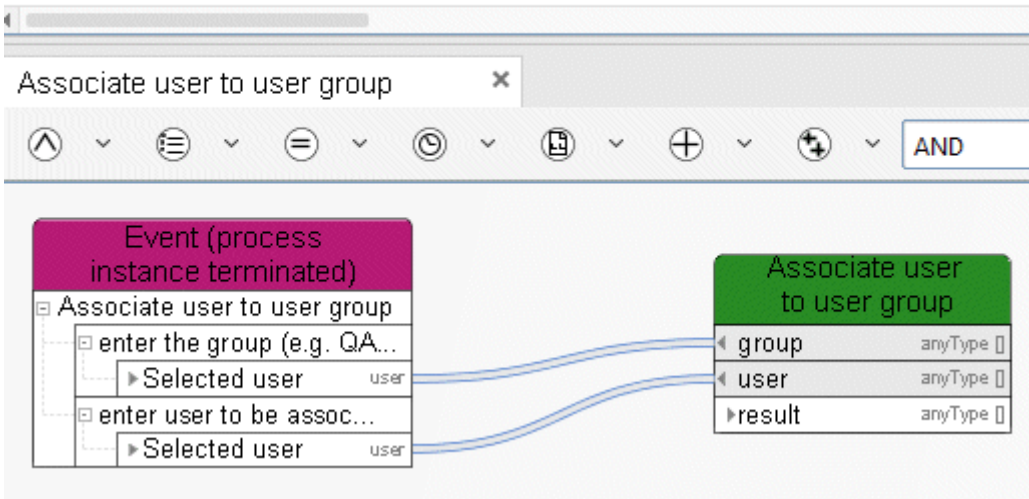
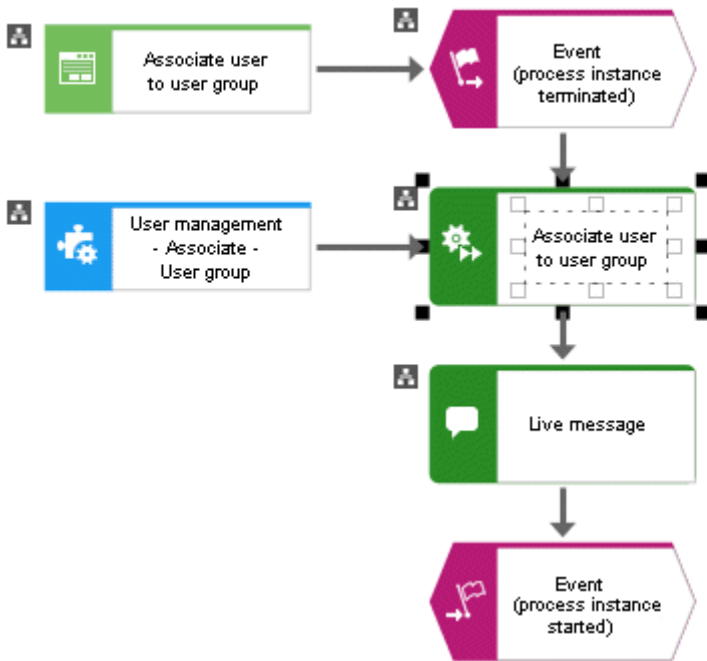

Figure 64: User management - Associate - User group

### 3.8.6 Create - User

This service generates a new user in the user management of Administration.

In/O ut	Name	Details	Data type
➔	Last name	Last name of the user to be generated.	<Text>
➔	Login name	Name that the user uses to log in.	<Text>
➔	First name	First name of the user to be generated.	<Text>
➔	Phone number	Phone number of the user to be generated.	<Text>
➔	User name	User name of the generated user.	<Text>

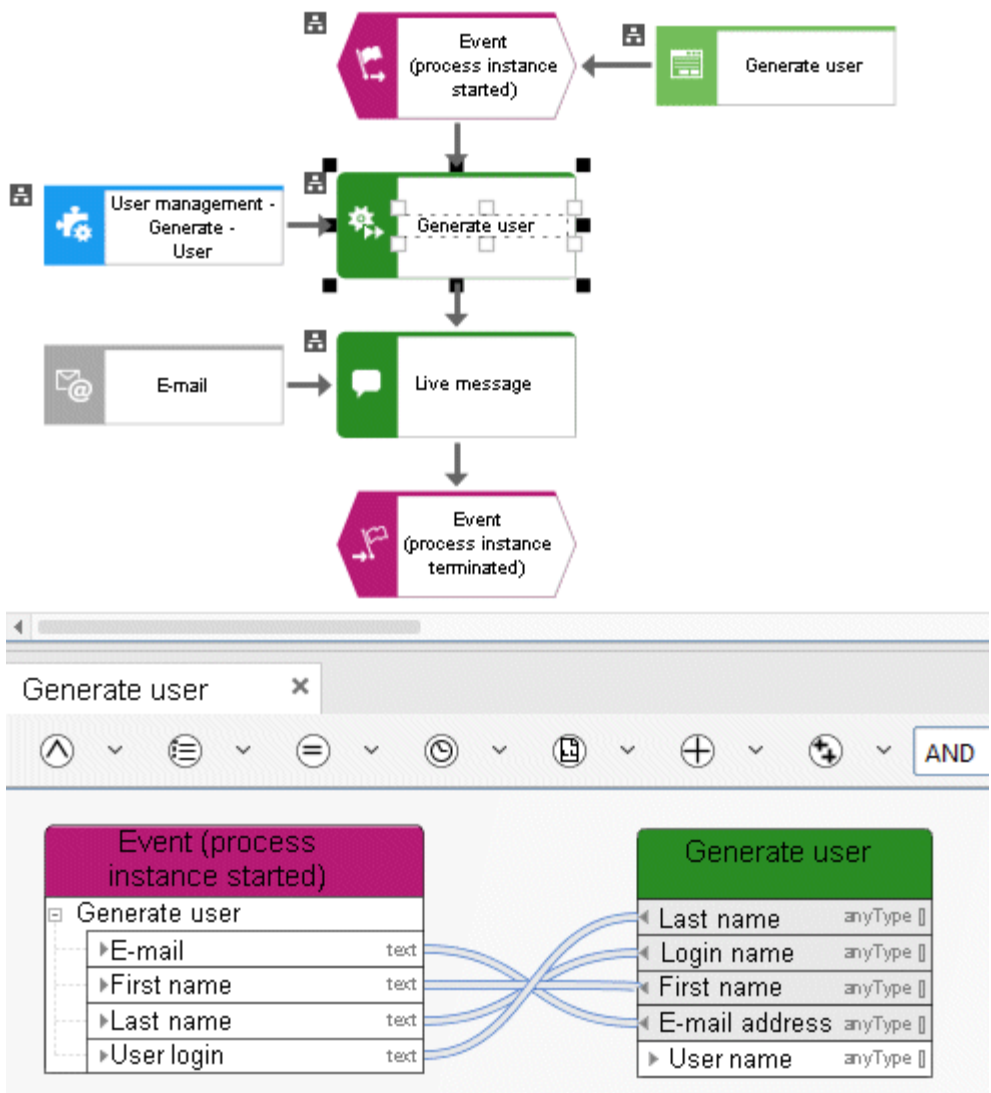



Figure 65: User management - Generate - User

### 3.8.7 Create - User group

This service generates a user group in the user management of Administration. The name of the user group is input data. If a user group with the same name already exists it is returned as output data.

In/Output	Name	Details	Data type
	User group name	Name of the user group to be generated in the database and in the user management of Administration.	<Text>
	User group name	The name of the generated user group.	<Text>

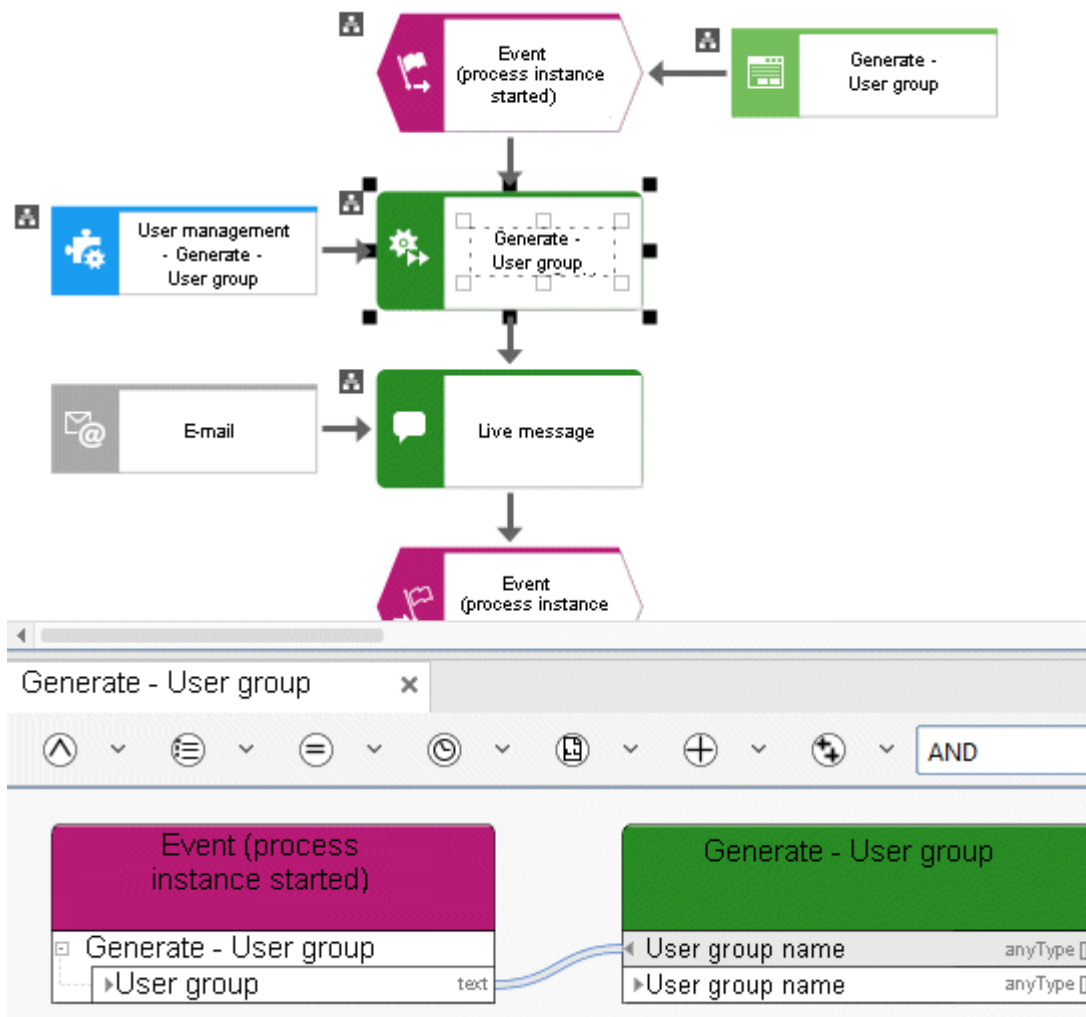



Figure 66: User management - Generate - User group

### 3.8.8 Delete - User

This service deletes a user from the user management of Administration.

In/O ut	Name	Details	Data type
	User	User to be deleted.	<User>

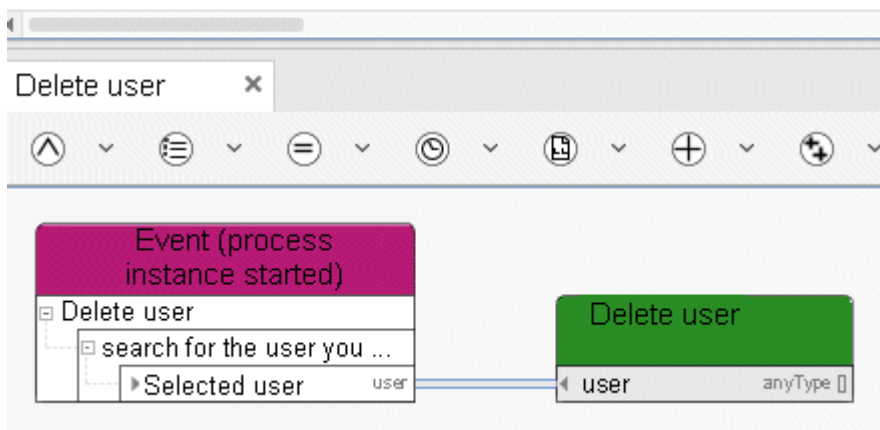
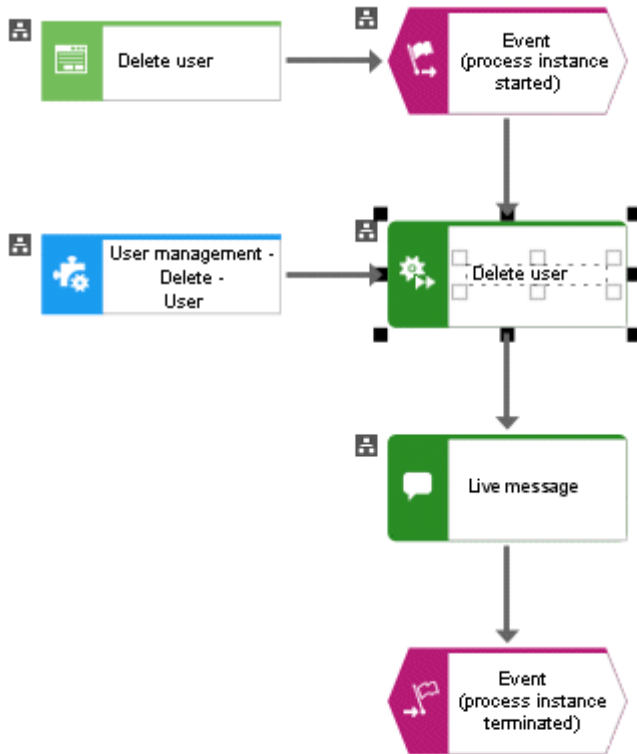

Figure 67: User management - Delete - User

### 3.8.9 Delete - User group

This service deletes a user group from the user management of Administration.

In/Output	Name	Details	Data type
	User group	User group to be deleted.	<User> or <text>

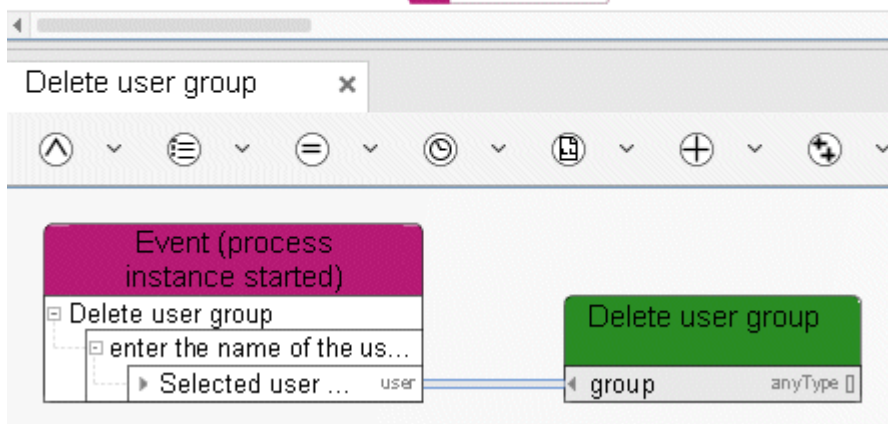
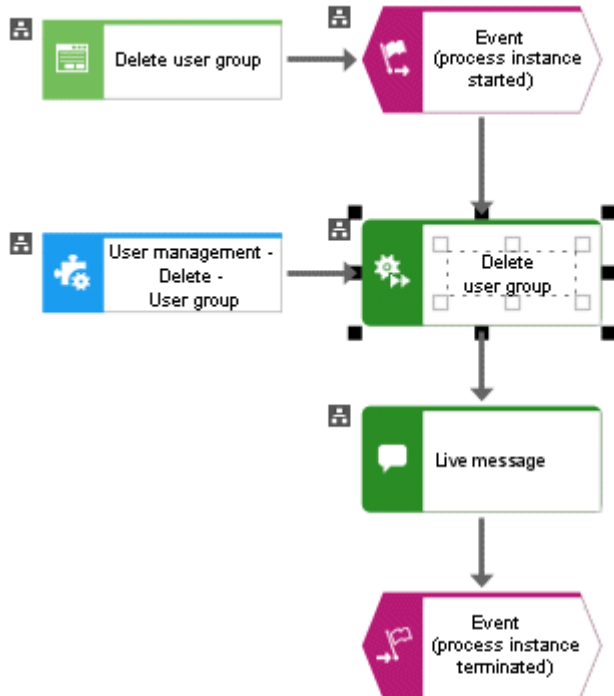



Figure 68: User management - Delete - User group

### 3.8.10 Retrieve - Architect user

This service checks if a user has an ARIS Architect license.

In/O ut	Name	Details	Data type
	User	User about which information is to be provided.	<User>
	Result	The result is TRUE if the user has an ARIS Architect license and FALSE if not.	<Boolean>

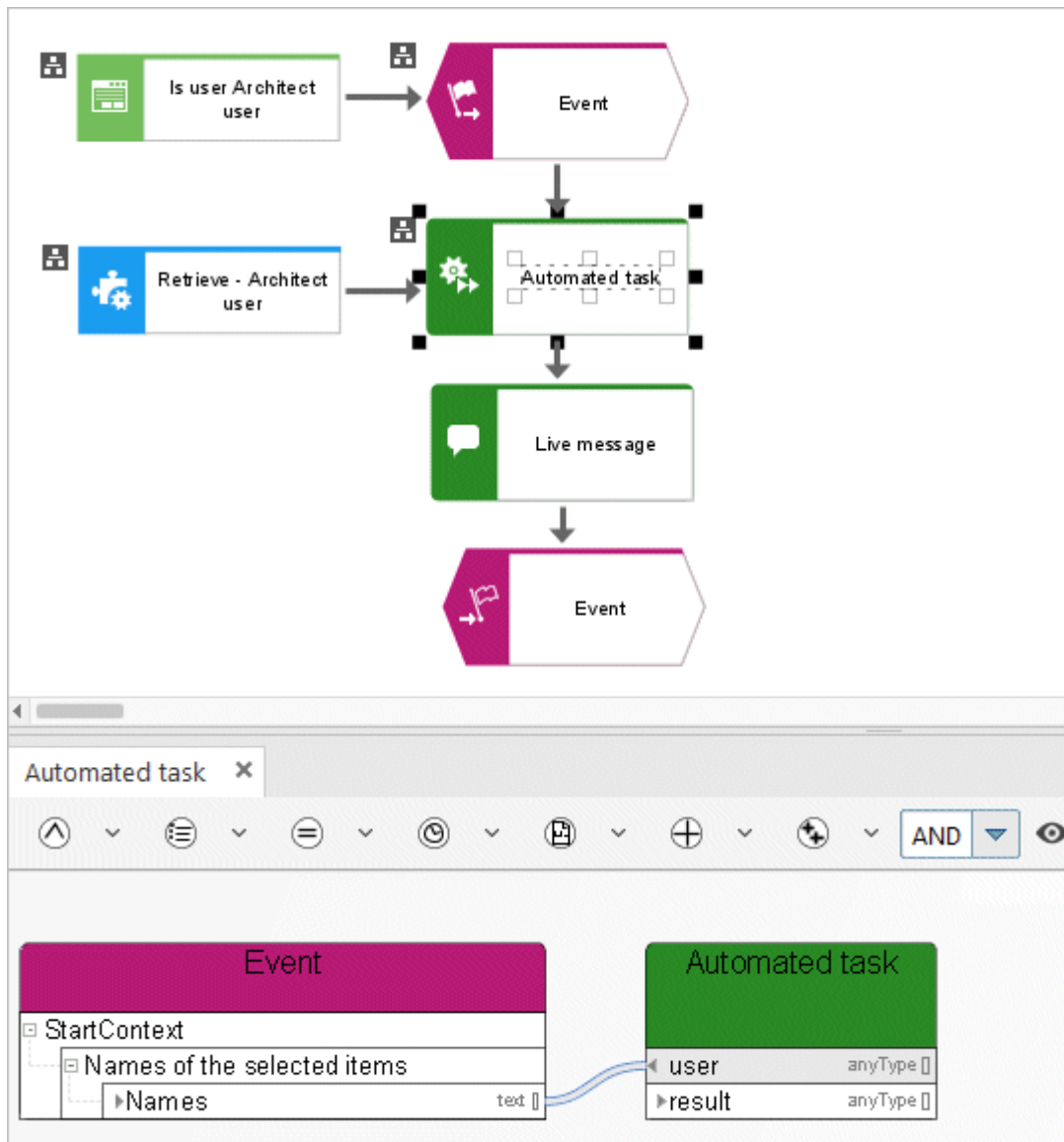



Figure 69: Retrieve - Architect user

### 3.8.11 Retrieve - Connect Designer user

This service checks if a user has an ARIS Connect Designer license.

In/Out	Name	Details	Data type
	User	User about which information is to be provided.	<User>
	Result	The result is TRUE if the user has an ARIS Connect Designer license and FALSE if not.	<Boolean>

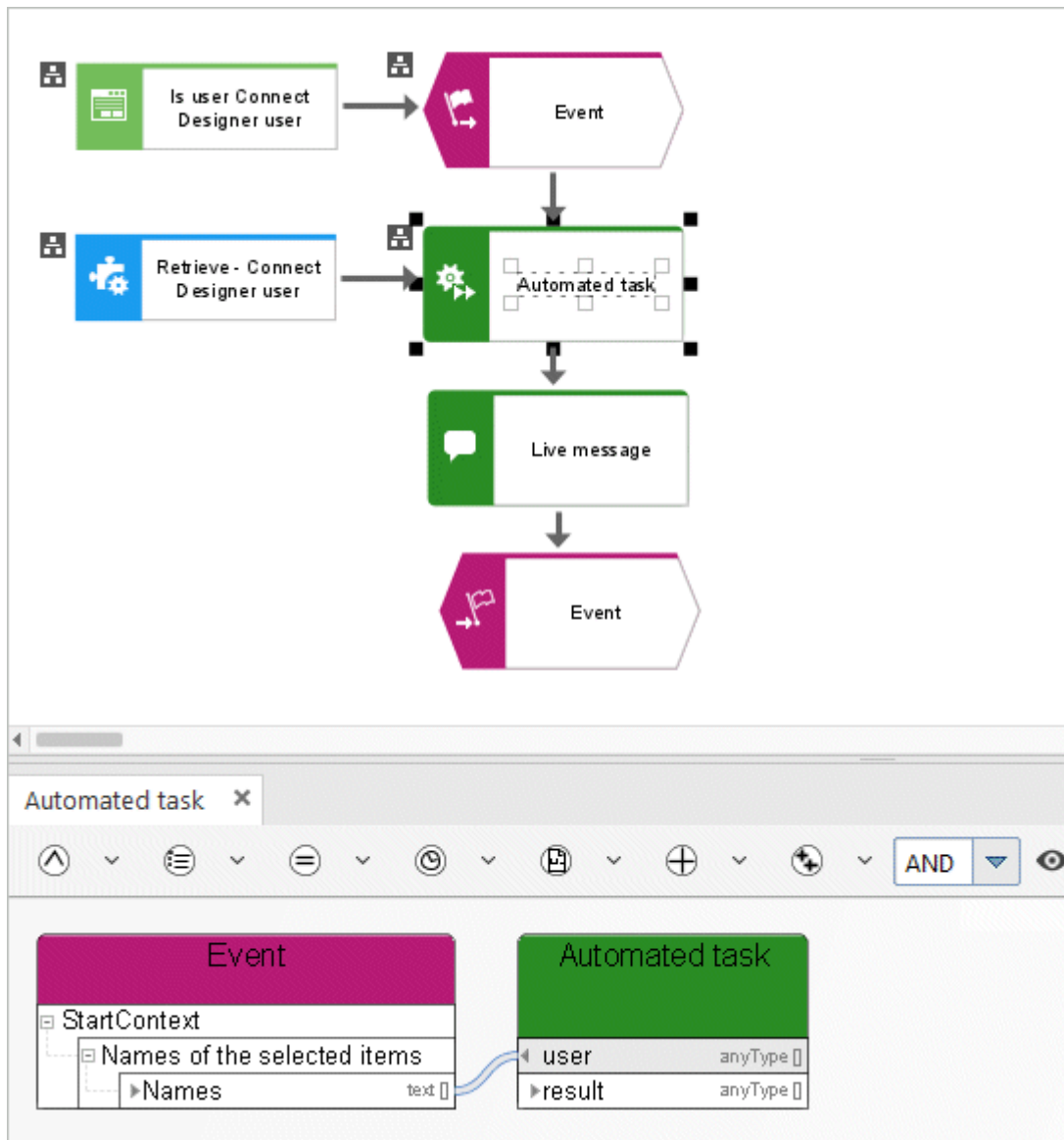

Figure 70: Retrieve - Connect Designer user



### 3.8.12 Retrieve - Process Board user

This service checks if a user has an ARIS Connect Viewer, ARIS Connect Designer or ARIS Viewer license.

In/Output	Name	Details	Data type
	User	User about which information is to be provided.	<User>
	Result	The result is TRUE if the user has a ARIS Process Board license and FALSE if not.	<Boolean>

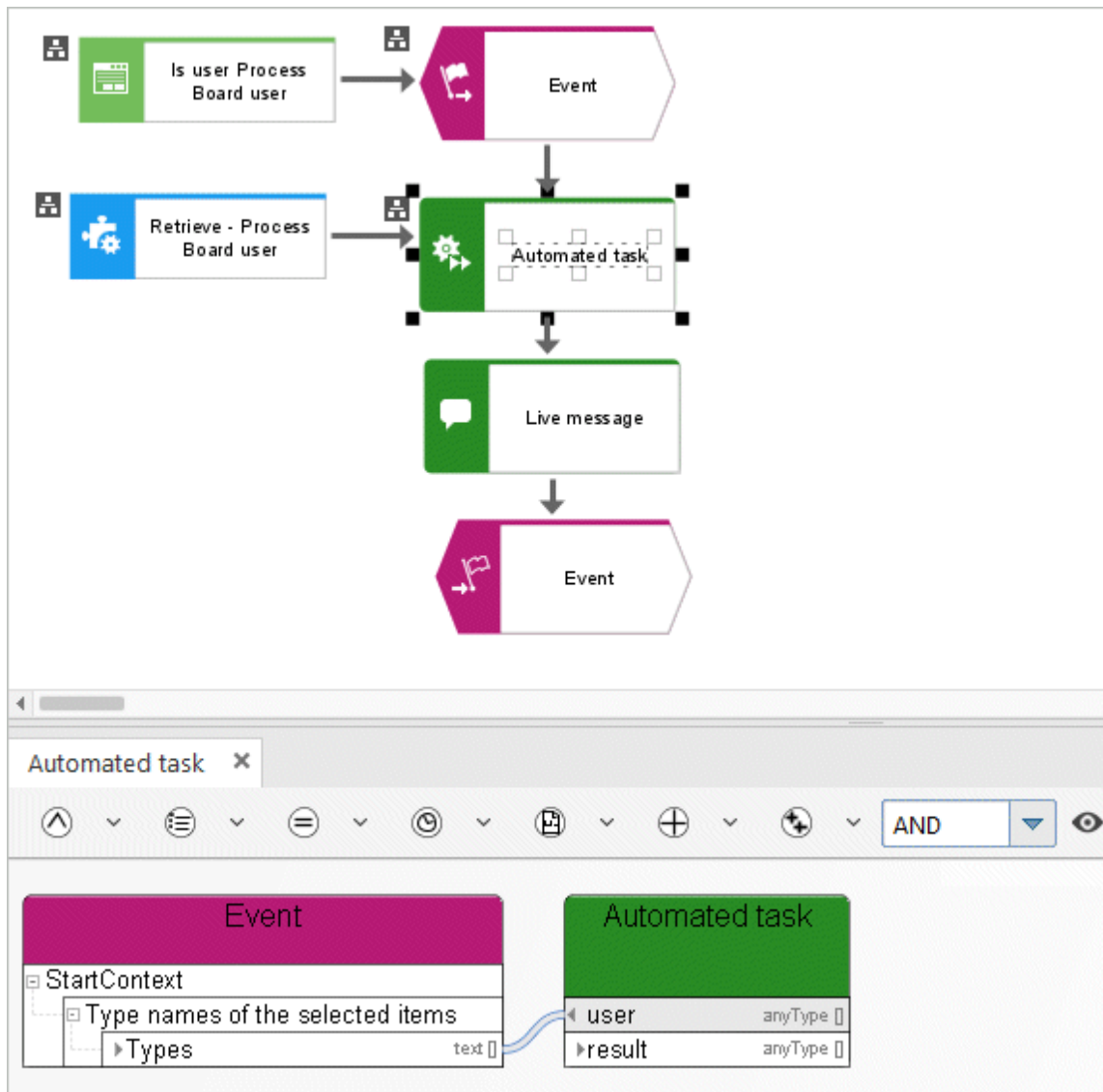





Figure 71: Retrieve - Process Board user

### 3.8.13 Retrieve - User belongs to user group

This service checks whether a user is associated with a specific user group in the user management.

In/Output	Name	Details	Data type
	User group	User group to be checked for user association.	<User> or <text>
	User	User to be checked for user group association.	<User> or <text>
	Result	The result is TRUE if the user belongs to the user group, otherwise FALSE.	<Boolean>

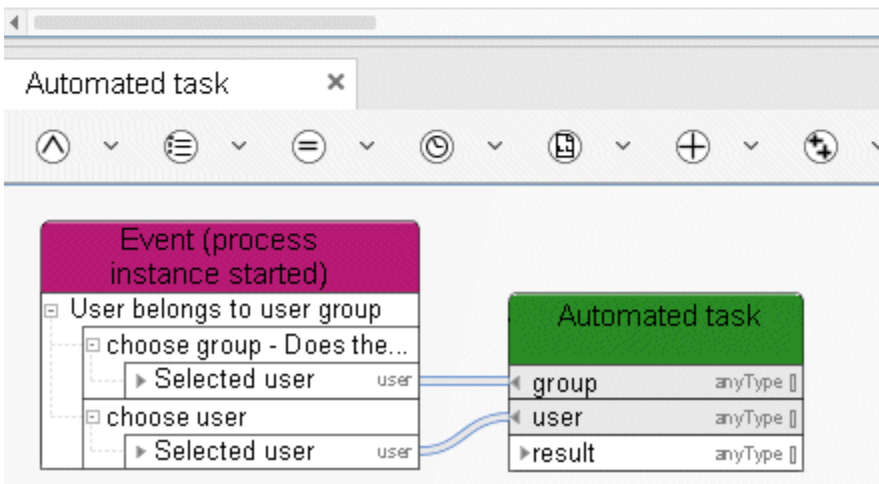
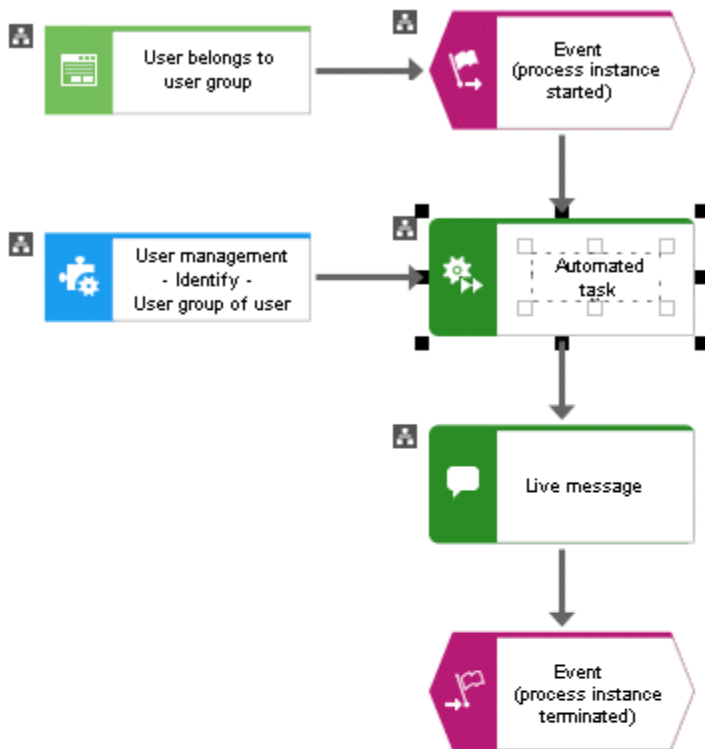



Figure 72: User management - Identify - User group of user

### 3.8.14 Retrieve - User groups of user

This service finds all user groups a user is associated with in the user management.

In/O ut	Name	Details	Data type
	User	User to be checked for user group association.	<User> or <text>
	Usergroups	The result is a list of user groups the selected user belongs to.	<Text collection>

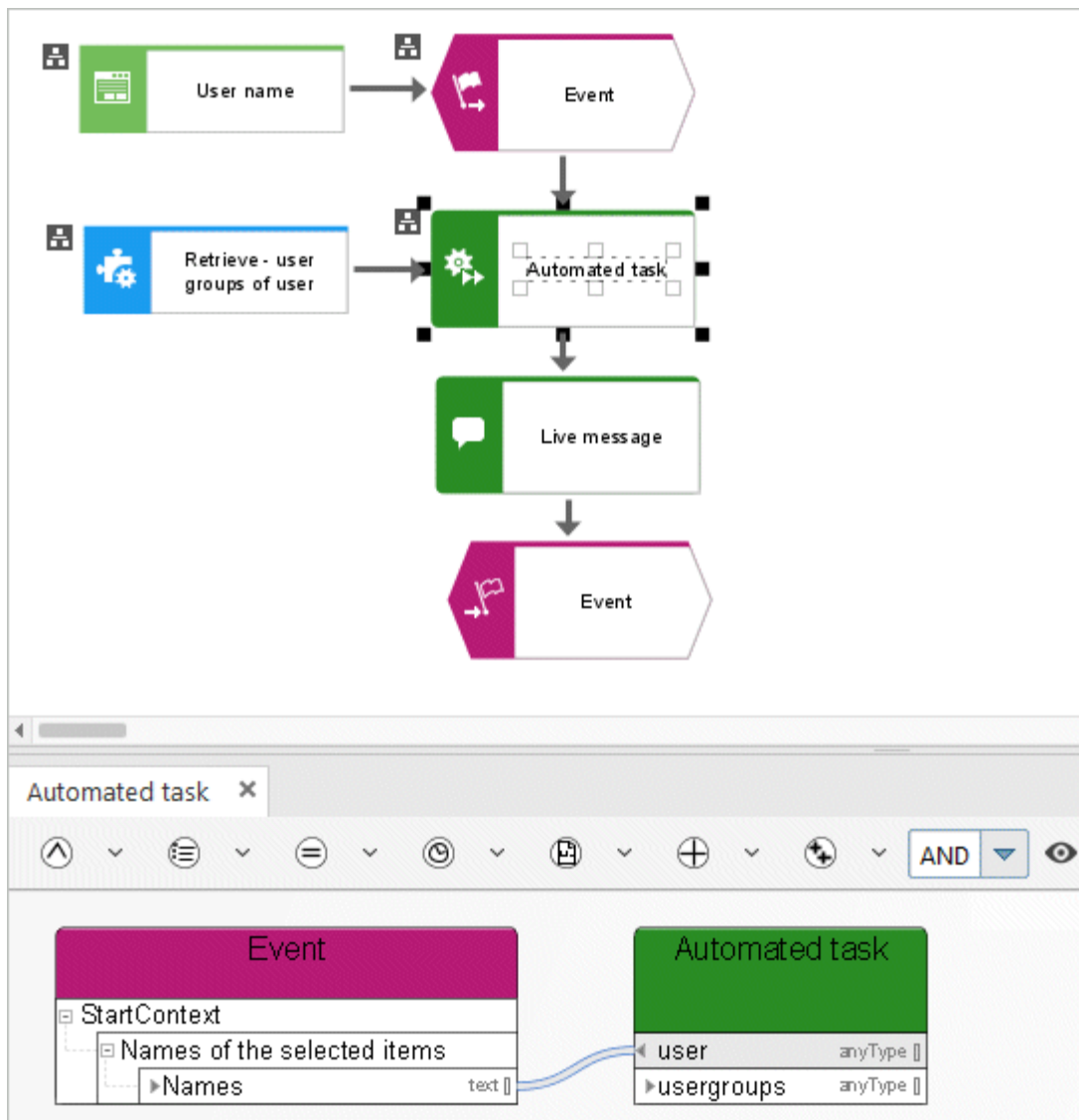









Figure 73: Retrieve - user groups of user

### 3.8.15 Retrieve - User information

This service retrieves information about a user from the user management of Administration.

In/Out	Name	Details	Data type
	User	User about which information is to be provided.	<User>
	E-mail address	E-mail address of the user.	<Text>
	Phone number of user	Phone number of the user.	<Text>
	UUID	Unique identifier of the user.	<Text>
	Login name	Name that the user enters when logging in.	<Text>
	Last name	Last name of the user.	<Text>
	Display name	Display name of the user.	<Text>
	First name	First name of the user.	<Text>

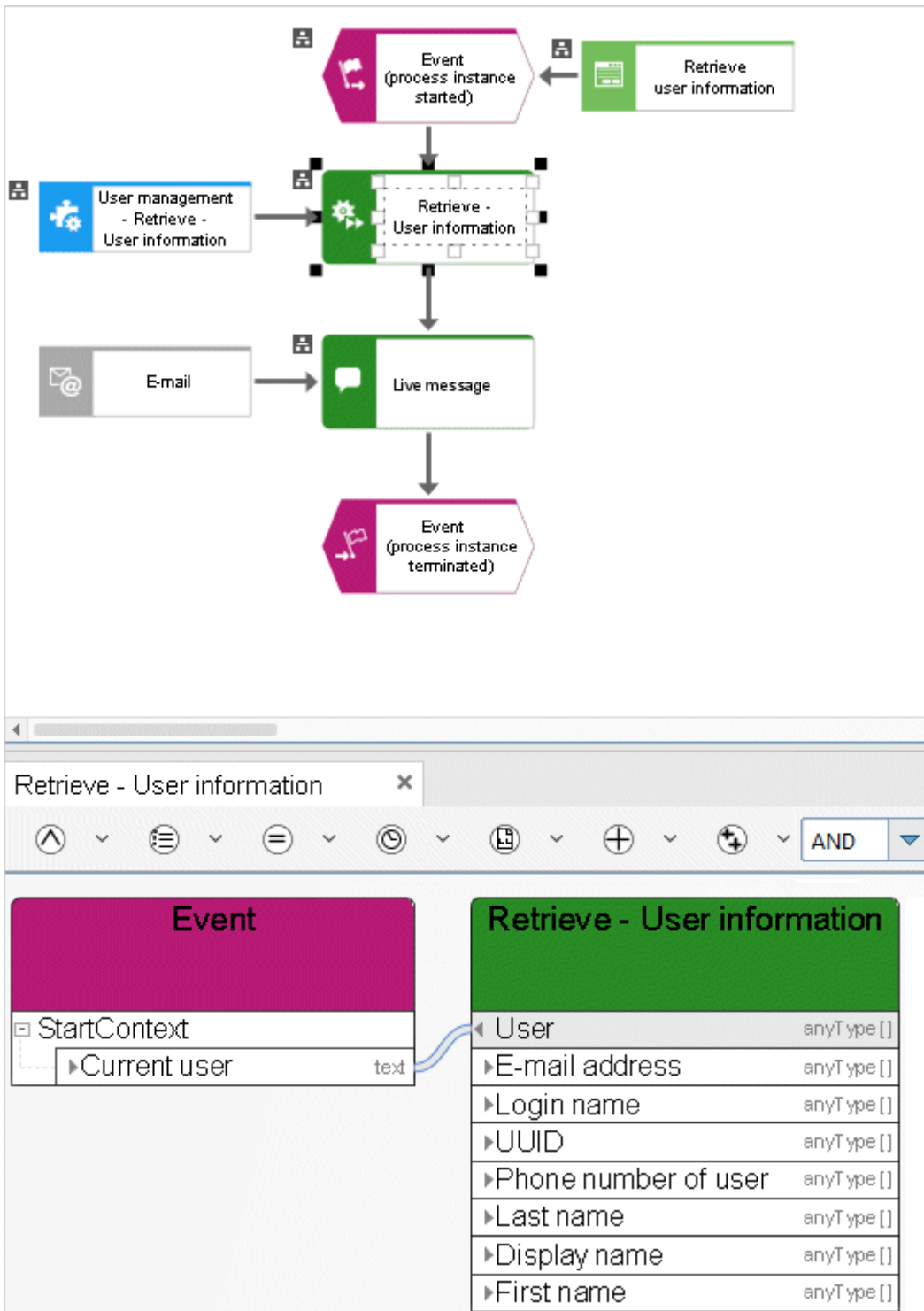

Figure 74: User management - Determine - User information

### 3.8.16 Retrieve - User selection empty

This service retrieves information on whether a user was selected or not in the user selection of a dialog that is displayed when a task is performed.

In/Output	Name	Details	Data type
	User	<b>Selected user</b> box in a dialog for which the information is to be retrieved.	<User>
	Result	The result is TRUE if at least one user was selected in the dialog, and FALSE if not.	<Boolean>

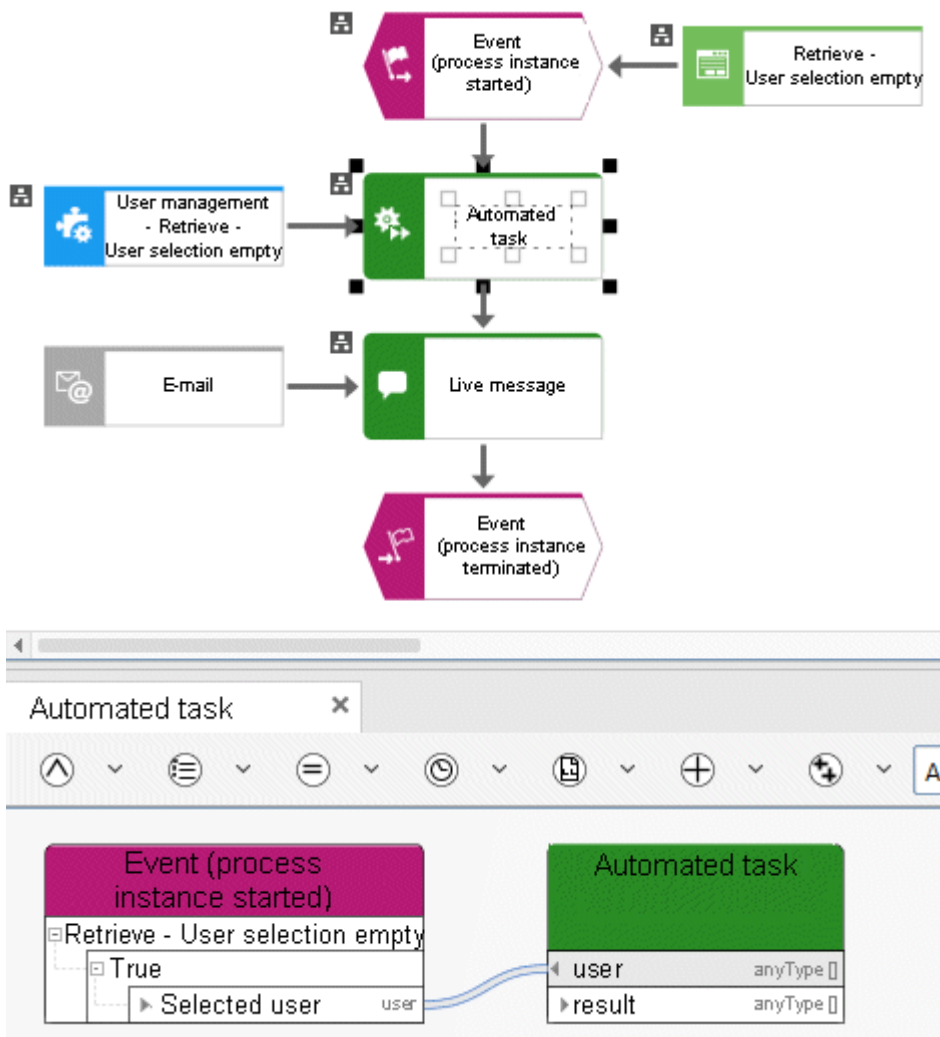

Figure 75: User management - Determine - User selection empty

### 3.8.17 Write - User information

This service updates information about a user from the user management of Administration.

In/O ut	Name	Details	Data type
➡	First name	First name of the user.	<Text>
➡	E-mail	New e-mail address of the user.	<Text>
➡	Last name	New last name of the user.	<Text>
➡	User	User whose information is to be updated.	<User>
⬅	User	Login name of the updated user.	<Text>

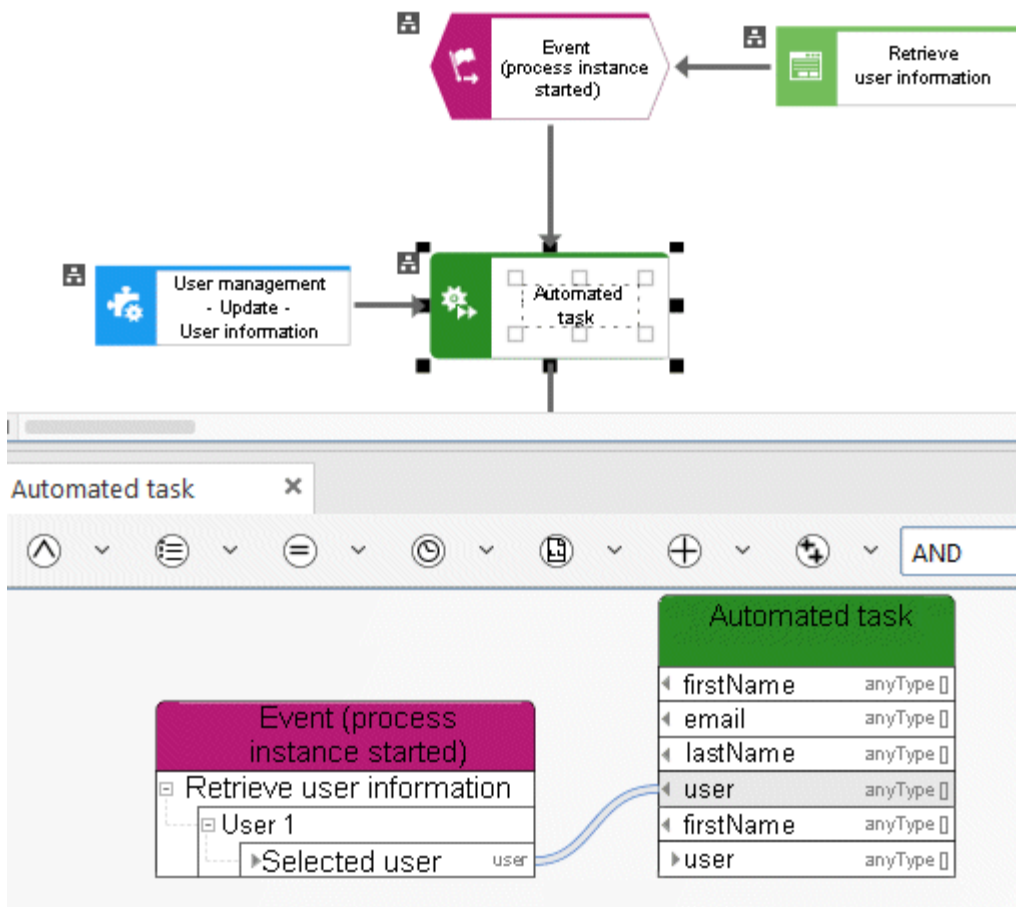



Figure 76: User management - Update - User information



### 3.9 Local services

#### 3.9.1 Compare - Boolean values

Compare Boolean attribute.

In/Output	Name	Details	Data type
	Attribute type	Define the Boolean attribute for which you want to know whether the value is set to TRUE or FALSE, or whether it is not specified (EMPTY). To do this, connect the result delivered by the service retrieving the Boolean attribute with this service as input data. Multiple items can be interpreted for the same attribute, e.g., a model attribute <b>Semantic check successful</b> for multiple EPCs.	<Any>
	Result	The service returns TRUE if the Boolean attribute was set to TRUE for all items. The service returns EMPTY if the Boolean attribute is not specified for at least one item. The service returns FALSE if the attribute is specified for all items and is set to FALSE for at least one item. The service also returns FALSE if less than two items can be compared.	<Any>

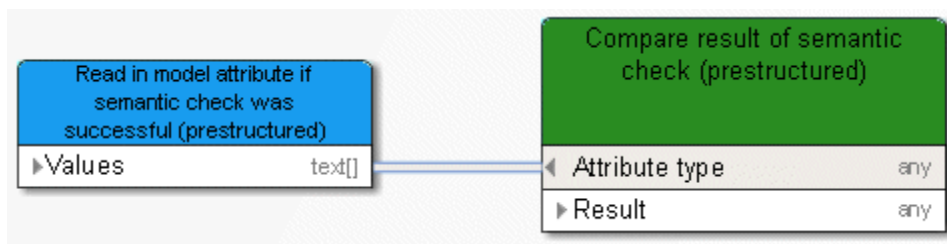



Figure 77: Compare Boolean

### 3.9.2 Compare - Future timestamps

The service compares a timestamp that was entered with the current timestamp.

In/Out	Name	Details	Data type
	Timestamp to be compared	Connect the timestamp of another object of type <b>Human task</b> or <b>Automated task</b> . This timestamp is compared with the current timestamp.	<Any>
	Result	The service returns TRUE if the timestamp that was checked is in the future. Otherwise, FALSE is returned.	<Any>

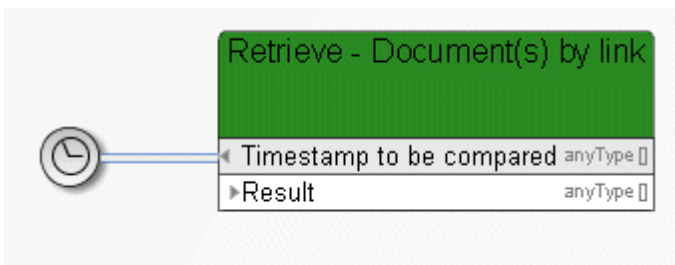

Figure 78: Check whether date is in the future

### 3.9.3 Compare - String

The service checks whether a text attribute is set to the same value for multiple terms, e. g., the attribute 'Status' for multiple models.





In/O ut	Name	Details	Data type
➔	Attribute type	Specify the text attribute for which you want to know whether its value is the same for multiple terms. To do this, connect the result delivered by the service retrieving the text attribute with this service as input data. Multiple items may be interpreted, e. g., a text attribute for multiple models of type EPC.	<Any>
➔	Result	The service returns TRUE if the text attribute was set to the same value for all items, e. g., <b>Released</b> for a model status attribute. The service returns FALSE if a different value was found in at least one item, e. g., if the model status attribute was set to <b>Released</b> for model 1, but to <b>Rejected</b> for model 2.	<Any>



Figure 79: Compare text attributes (strings)

### 3.9.4 Compare - Time attributes

The service compares two time attributes of models or objects and checks whether one timestamp is more recent than the other. In addition, a list of models or objects is output whose time attribute is more recent than the one compared.

In/Output	Name	Details	Data type
	Time attributes (older)	Define the attribute values that are to be older. To do this, connect output data of <b>Automated task</b> objects with the required time attributes. Example: the latest change attribute of predefined models.	<Any>
	Time attributes (more recent)	Define the attribute values that are to be more recent. To do this, connect output data of <b>Automated task</b> objects with the required time attributes. Example: the time when the semantic check was performed for predefined models.	<Any>
	Selected items	Select the models or objects you want to find. To do this, connect models, objects, or groups from the preselection of another object of type <b>Human task, Automated task, or Event (process instance started)</b> , or enter GUIDs and use the <b>Create collection</b> operator.	<Any>
	Result	The service returns TRUE (Boolean) if the time attribute (more recent) is more recent than the time attribute (older) for at least one of the compared models or objects. The service returns EMPTY if the time attribute (more recent) is not specified for at least one of the compared models or objects. Otherwise the service returns FALSE (Boolean).	<Any>
	List of items for TRUE and EMPTY	The service lists all models or objects meeting one of the following check criteria: Time attribute (more recent) is more recent than Time attribute (older), or Time attribute (more recent) is not specified.	<Any>

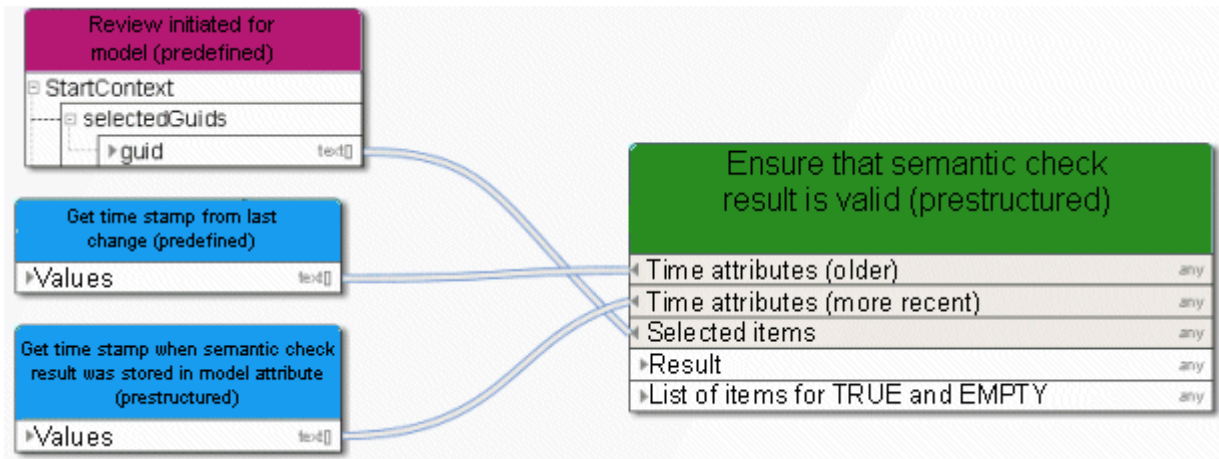





Figure 80: Compare time attributes

### 3.9.5 Compare - Value empty

The service checks whether or not predefined values (e. g., attributes) are specified.

In/Output	Name	Details	Data type
	Values to be checked	Enter the values to be checked. To do this, connect the service to retrieve an attribute from multiple models, for example.	<Any>
	At least one value not specified	The service returns TRUE (Boolean) if at least one value is not specified in the list. Otherwise the service returns FALSE (Boolean).	<Any>
	No values specified	The service returns TRUE (Boolean) if no values are specified in the list. Otherwise the service returns FALSE (Boolean).	<Any>

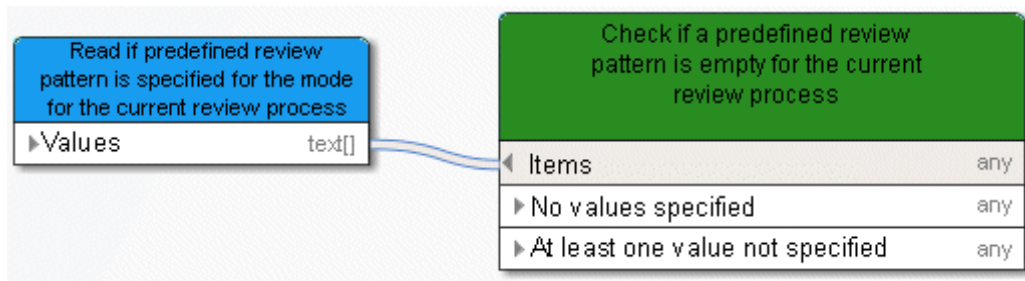

Figure 81: Compare whether values are specified

### 3.9.6 Create - Change number(s)

The service increments the version number by a predefined value.

In/O ut	Name	Details	Data type
➡	Selected values	You can enter a list of numbers to be checked, e. g., the list of the <b>Version number</b> attribute from all models. To do so, connect the numbers of another object of type <b>Human task</b> , <b>Automated task</b> , or <b>Event (process instance started)</b> , or define constants. Then use the <b>Create collection</b> operator.	<Any>
➡	Increment by number	Enter the number by which a predefined value is to be incremented. To do so, connect a number of another object of type <b>Human task</b> , <b>Automated task</b> , or <b>Event (process instance started)</b> , or define a constant of the type <b>Decimal</b> .	<Any>
⬅	Selected values	The service returns a list of the changed values.	<Any>

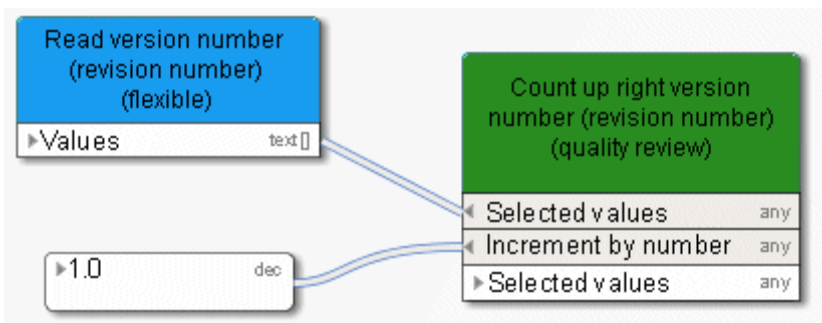





Figure 82: Create or change number(s)

### 3.9.7 Create - Human task log

The service returns the input a person enters in the dialog when carrying out a function of type **Human task**. The result delivered by the service can, for example, be entered in the **Change list** attribute of a model or object to ensure detailed documentation.

In/Output	Name	Details	Data type
	Dialog elements	Copy the function of type <b>Human task</b> as a recurring task and connect the recurring task with a dialog element, e. g., a comment. To log more than one dialog element use the <b>Concatenate</b> operator. Please use constants for structuring the connected dialog element input, e. g., model a constant with the dialog element name before connecting the dialog element itself. You may also use constants as separators, e. g., spaces and semicolons.	<Any>
	Executor IDs	Copy the <b>Human task</b> function you want to log as a recurring task and connect it to the field containing the IDs of the executors. Logging is done for each executor.	<Any>
	Result	Entries by an executor of the connected <b>Human task</b> function that was copied as a recurring task are logged for the selected dialog elements per executor and entry. The result delivered by the service can, for example, be entered for the <b>Change list</b> attribute of a model or object to ensure detailed documentation of what input executors specified for the dialog of the <b>Human task</b> function type.	<Any>



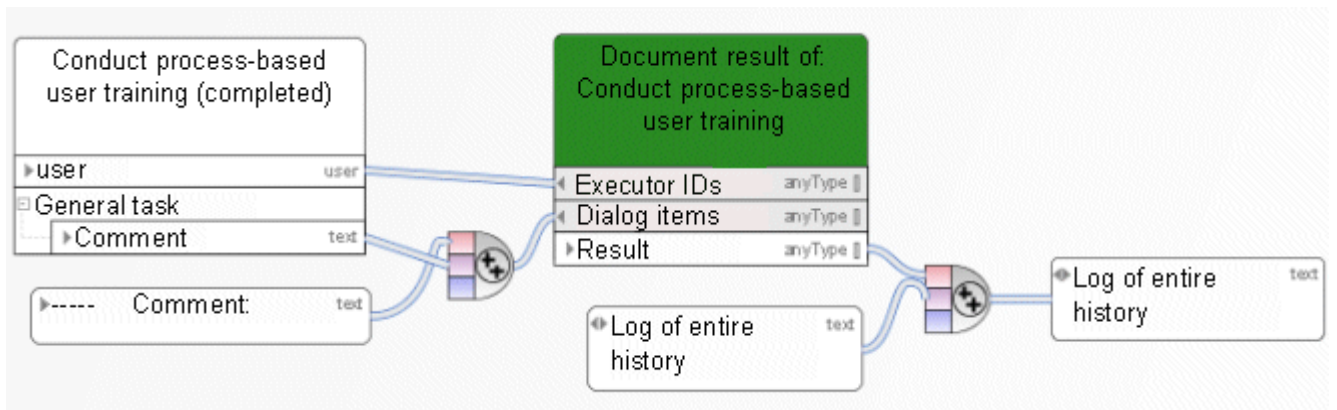







Figure 83: Log user input

### 3.9.8 Retrieve - Link (design)

The service provides a list of model links. These links may be used as input data for a dialog to enable the user to access the ARIS modeling database. The linked model opens and can be edited.

In/Output	Name	Details	Data type
	Database name	Connect the database where your models are stored. To do this, connect an object of type <b>Event (process instance started)</b> , <b>Human task</b> , or <b>Automated task</b> .	<Any>
	Language	Language an object of type <b>Automated task</b> uses to log into the database, e. g., <b>en</b> for English.	<Any>
	Server	Connect the server on which the database is stored. To do this, use the object of type <b>Event (process instance started)</b> .	<Any>
	Selected models	Select the models you want to find. Connect models from the preselection of another object of type <b>Human task</b> , <b>Automated task</b> , or <b>Event (process instance started)</b> .	<Any>
	Link list	A link list is provided for all relevant models. The links may be used as input data for a dialog to enable the user to access the ARIS modeling database. Please note: Exactly one link is allowed for each link field in a dialog. The service provides a list of links if more than one link is specified for accessing a model. In the data flow of a dialog, model every single link by using an operator determining the selection.	<Any>

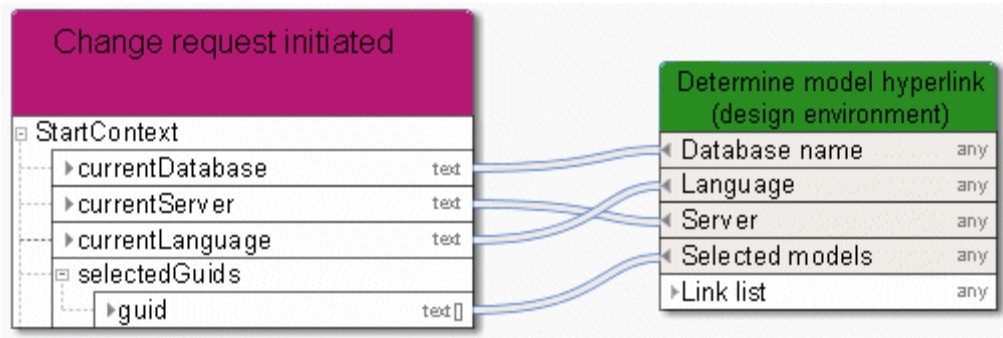

Figure 84: Output link to model (design)

### 3.9.9 Retrieve - Number (highest/lowest)

The service compares given numbers and returns the highest or lowest number.



In/Out	Name	Details	Data type
	List of numbers	The service compares a list of numbers. Either connect the numbers of another object of type <b>Human task, Automated task, or Event (process instance started)</b> , or define constants. Always use the <b>Create collection</b> operator.	<Any>
	Required selection	The service outputs the highest or lowest number from a given list. Enter TRUE (Boolean) if the service is to return the highest number from a given list. Enter FALSE (Boolean) if the service is to return the lowest number from a given list. FALSE (Boolean) is used as the default value if no value is specified.	<Any>
	Result	The result is the highest or lowest number from a list of numbers.	<Any>



Figure 85: Select highest/lowest number

### 3.10 Operators in the data flow

#### 3.10.1 Numerical operators

##### 3.10.1.1 Add

 Addition of numbers or a date with a time span, e. g., May 11 + 10 days results in May 21.

The following combinations are possible:

First slot	Second slot	Result
Date	Duration	Date
Date and time	Duration	Date and time

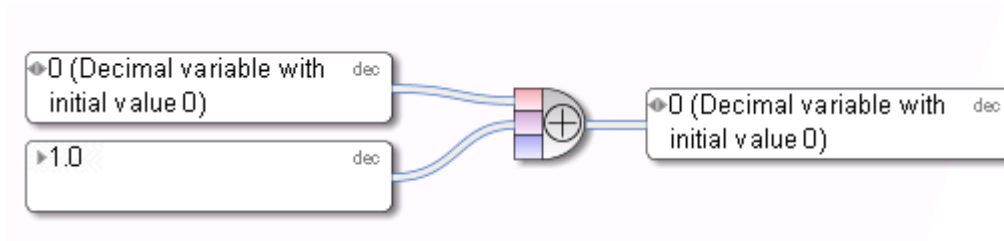

Figure 86: Add

### 3.10.1.2 Subtract



Subtraction of numbers or a date with a time span - the second entry is subtracted from the first. Example: May 11th - 10 days results in May 1st.

The following combinations are possible:

First slot	Second slot	Result
Date	Date	Duration
Date	Duration	Date
Date and time	Duration	Date and time
Date and time	Date and time	Duration

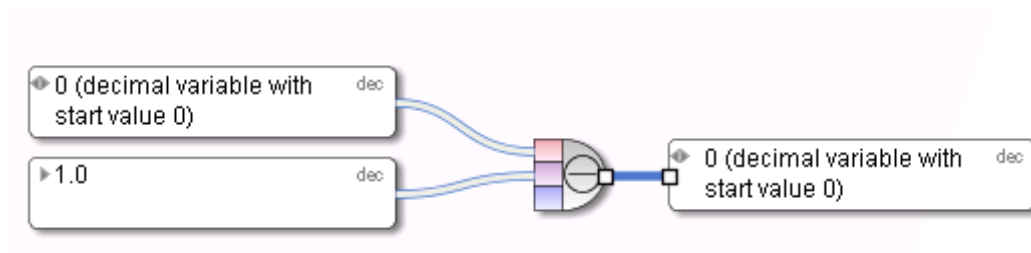

Figure 87: Subtract

### 3.10.1.3 Multiply



Multiply numbers

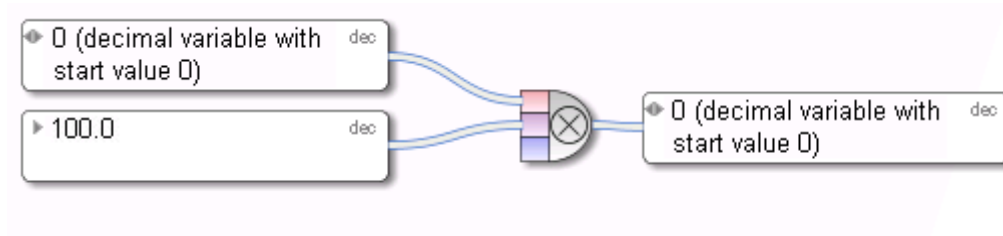

Figure 88: Multiply

### 3.10.1.4 Divide



Divide numbers

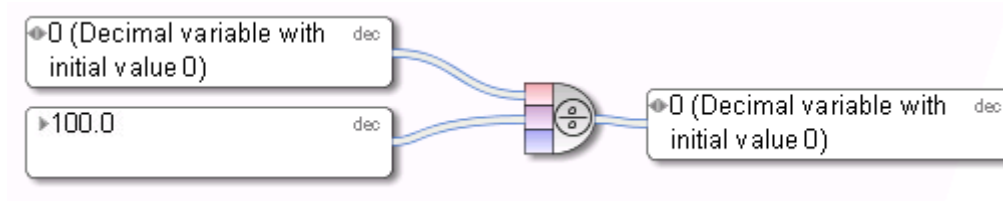



Figure 89: Divide

### 3.10.2 Comparison operators

#### 3.10.2.1 Equal to

 Mathematical operator **Equal to** returns TRUE if both incoming objects are equal.

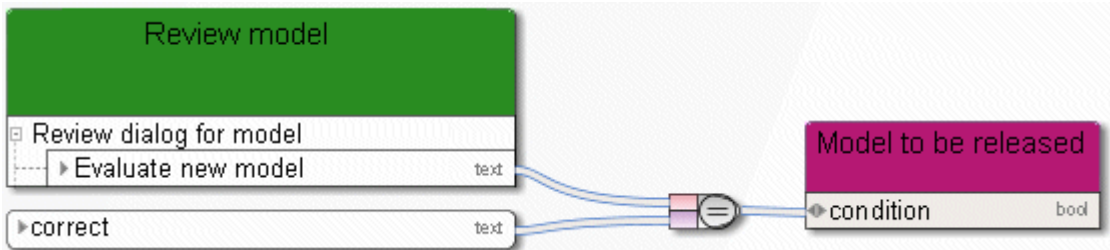



Figure 90: Equal to

#### 3.10.2.2 Not equal to

 Mathematical operator **Not equal to** returns TRUE if both incoming objects are not equal.

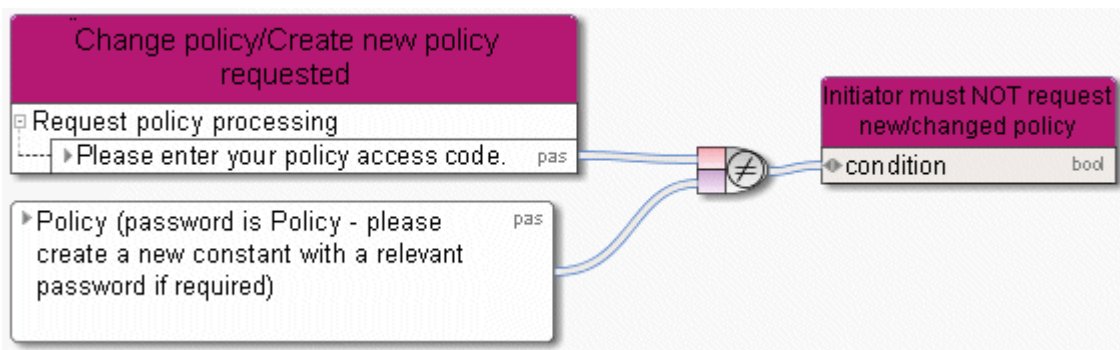



Figure 91: Not equal to



### 3.10.2.3 Greater than

 Mathematical operator **Greater than**

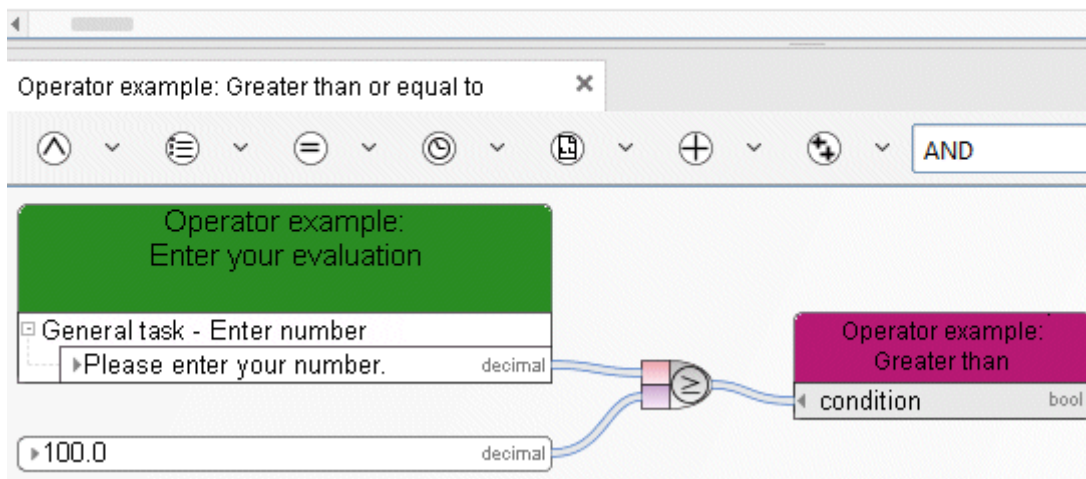
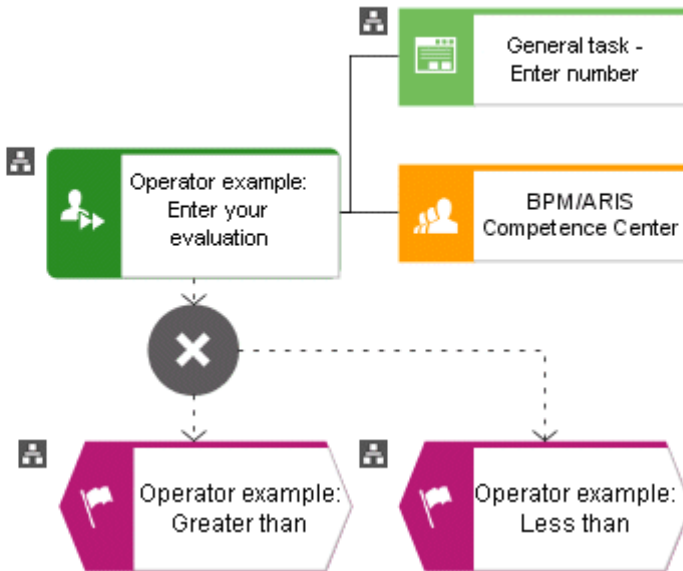

Figure 92: Greater than

### 3.10.2.4 Greater than or equal to

 Mathematical operator **Greater than or equal to**

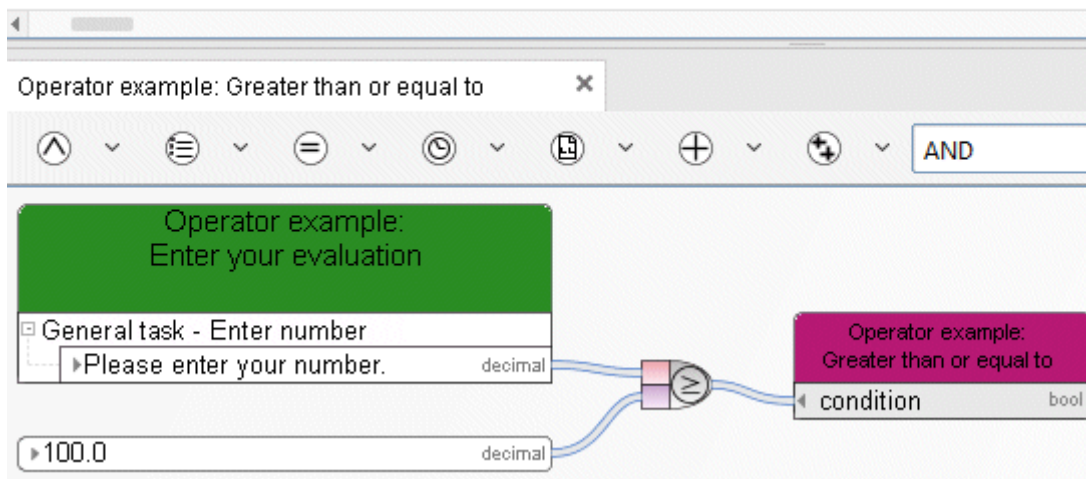
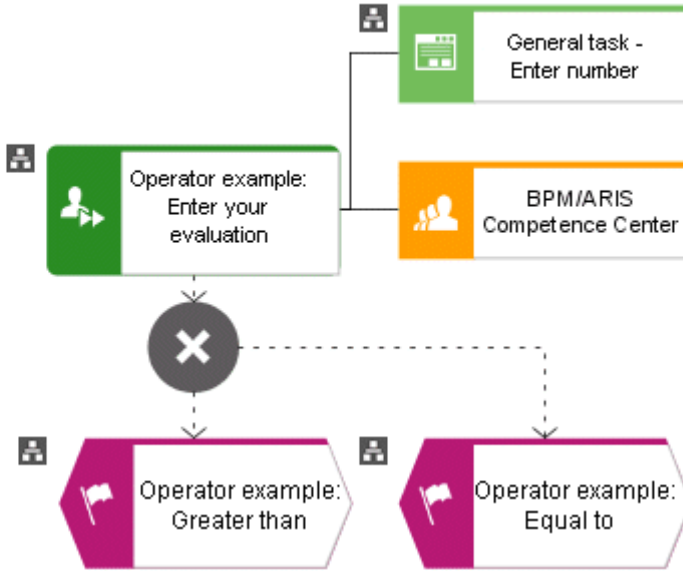



Figure 93: Greater than or equal to

### 3.10.2.5 Less than

 Mathematical operator **Less than**

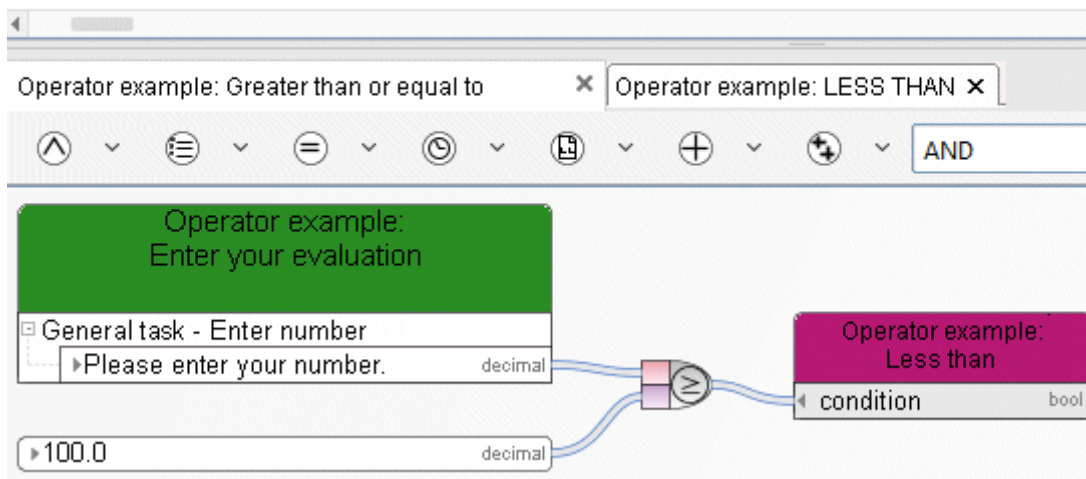
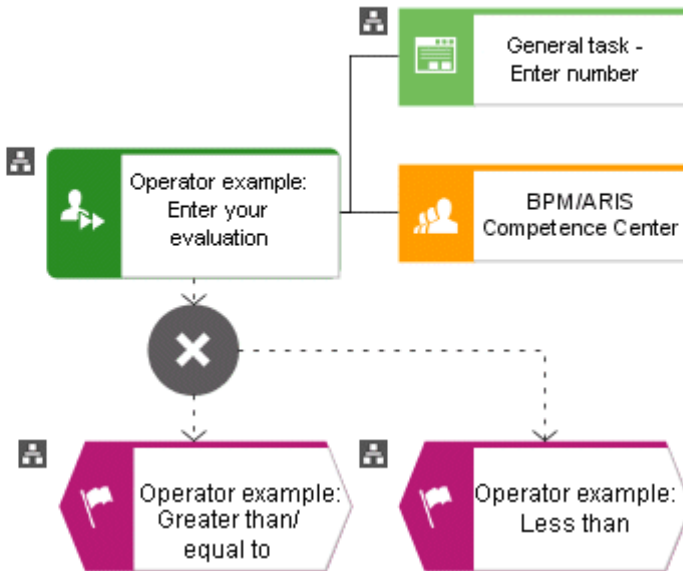



Figure 94: Less than

### 3.10.2.6 Less than or equal to

	Mathematical operator <b>Less than or equal to</b>
---	--

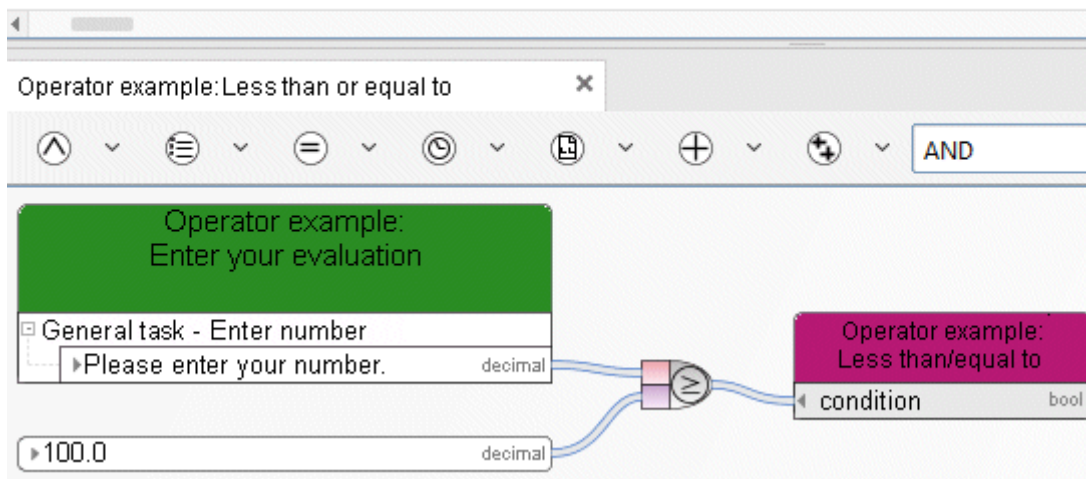
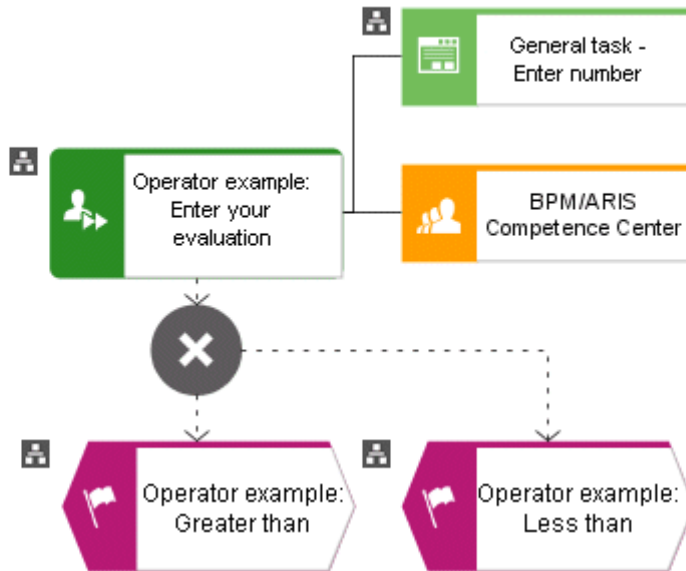



Figure 95: Less than or equal to

### 3.10.3 Boolean operators

#### 3.10.3.1 AND operator

 The **AND** operator is a Boolean operator and represents the condition that all incoming objects exist in the process instance.

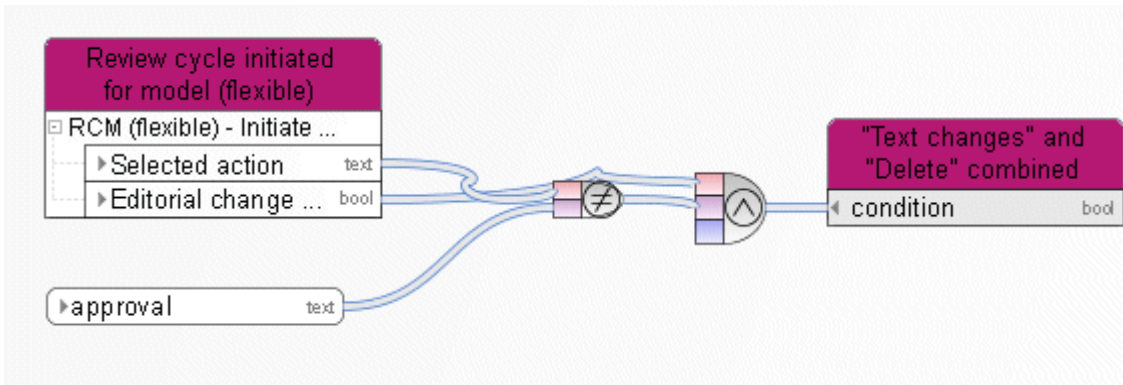



Figure 96: AND

#### 3.10.3.2 OR operator

 The **OR** operator is a Boolean operator. It represents the condition that at least one incoming object must exist in the process instance.

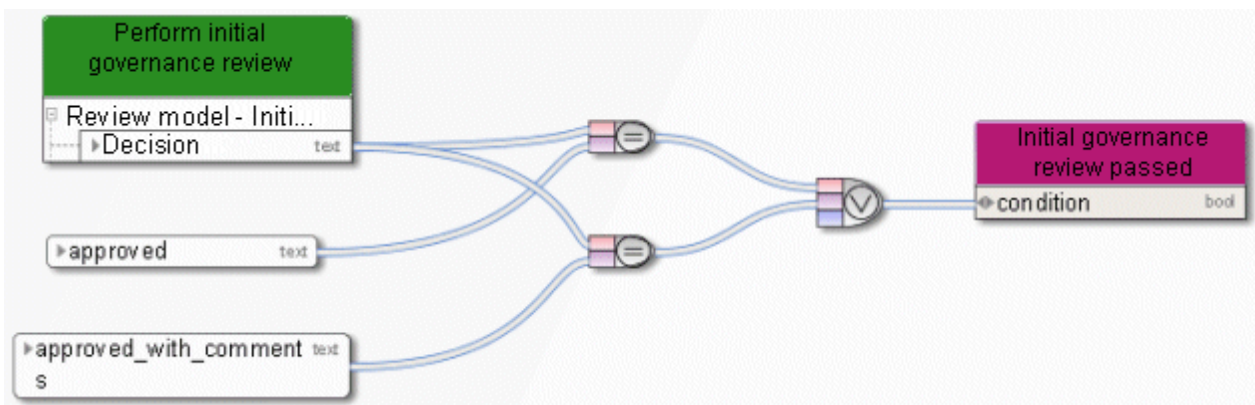

Figure 97: OR

### 3.10.3.3 NOT operator



The **NOT** operator is a Boolean operator. This operator inverts the value of a Boolean variable. In the graphic the incoming object is the variable **Temporary files created**. Thus, the operator specifies whether the condition that temporary files are not to be deleted is met.

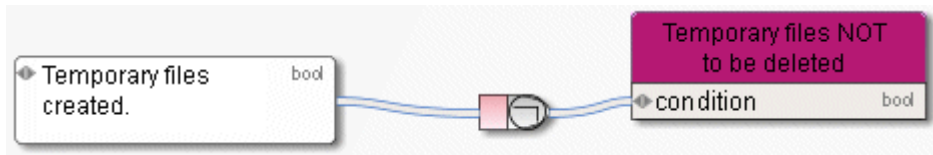

Figure 98: NOT

### 3.10.4 What are operators for collections?

#### 3.10.4.1 Select item by ID

**1** Returns a list item with a specific ID. The first parameter this operator requires is the list from which an item is to be selected. The second parameter of this operator is the ID (key) of the required items.

The corresponding attribute is selected from the list via the API name.

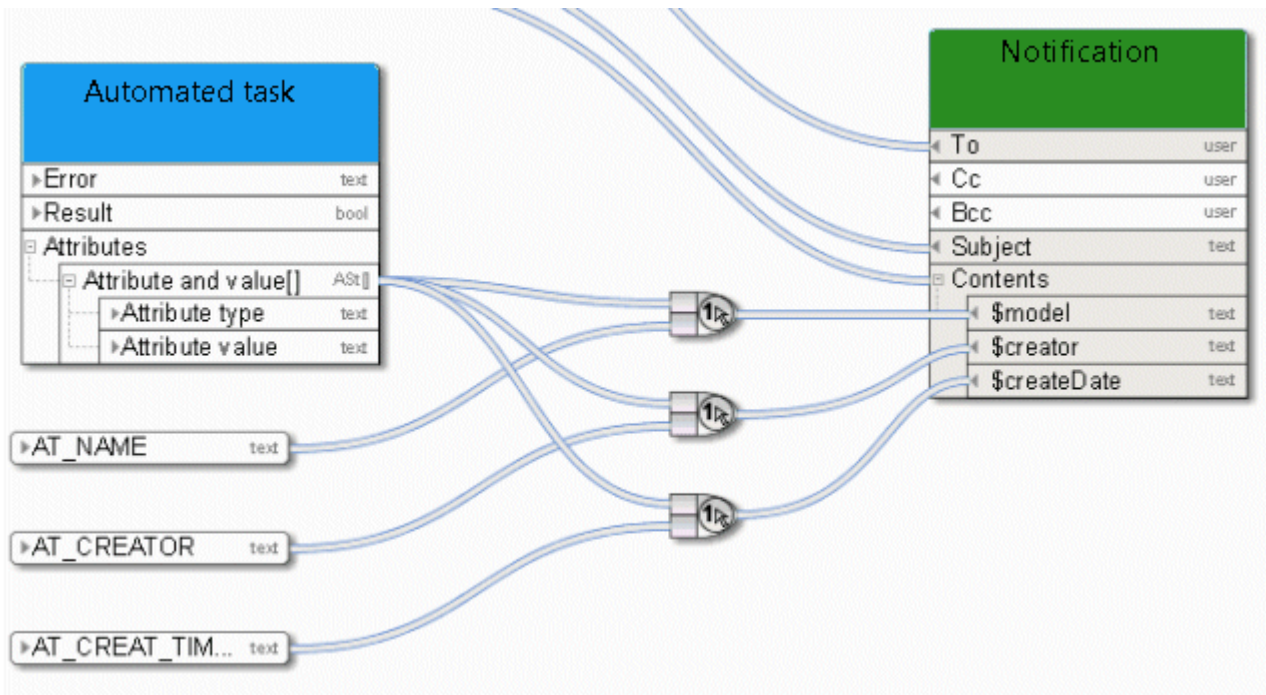



Figure 99: Select item by ID

### 3.10.4.2 Select item by position

 Returns an item from an indexed list (collection) in accordance with the transferred integer index values. The first parameter is the collection, the second parameter the index.

Here the service provides a list of links from which the first item is selected for further processing.

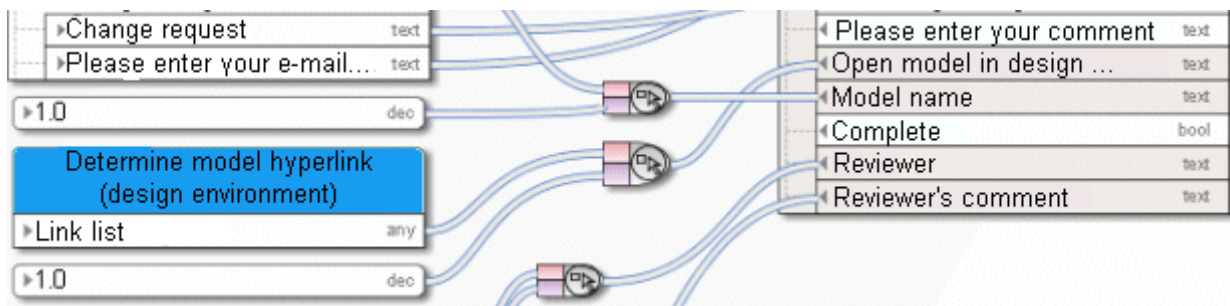



Figure 100: Select item by position

### 3.10.4.3 Create collection

 Creates a collection (lists, data series) of objects of the same type. The operator is used here to define a list of attribute types that are processed further by a service.

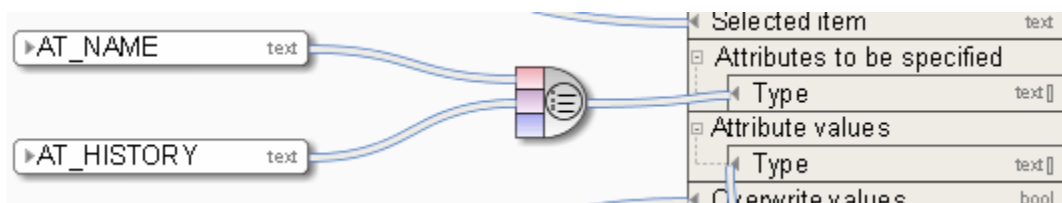

Figure 101: Create collection



### 3.10.4.4 Determine size of collection



Retrieves the number of items in a collection (list, data series) of objects of the same type and outputs them as integers.

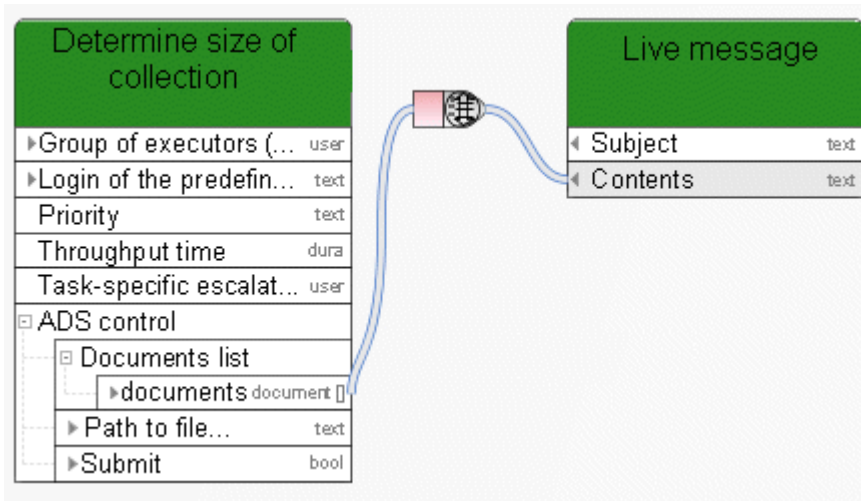

Figure 102: Determine size of collection

### 3.10.4.5 Create intersection of collections



Determines the intersection of two lists. For example, if one list contains the numbers **10**, **113**, and **127**, and a second list contains the numbers **1** and **127**, the operator returns the number **127**. The operator can be used for lists of all data types.

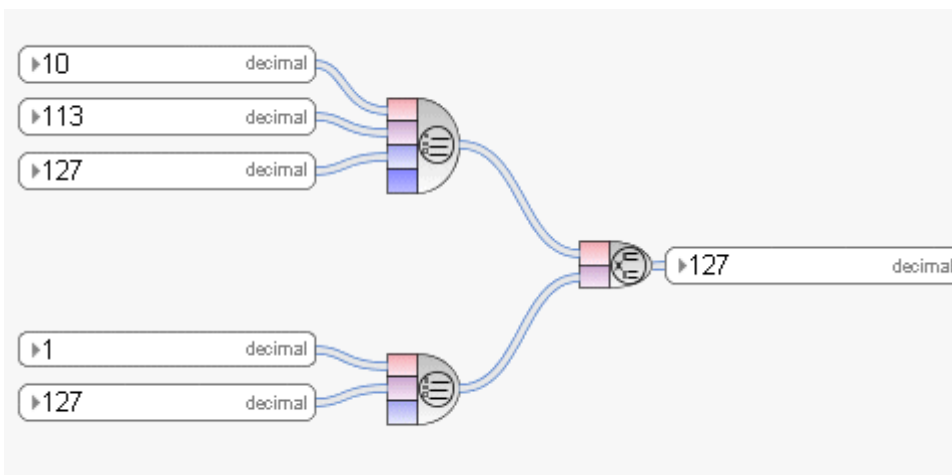



Figure 103: Create intersection of collections

### 3.10.4.6 Format lines

 Creates a new string from collections. The string contains all objects of the collections separated by line feed while maintaining the original order.

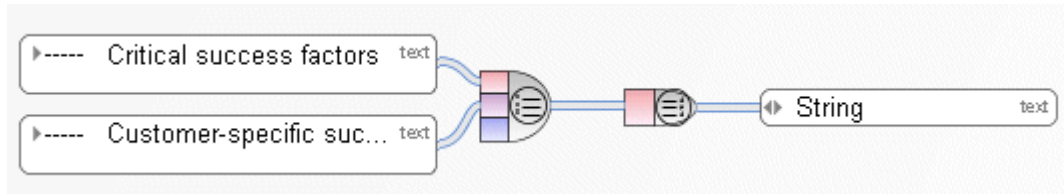



Figure 104: Transform collection into string

### 3.10.4.7 Validate collection

 The operator checks whether a collection is valid.

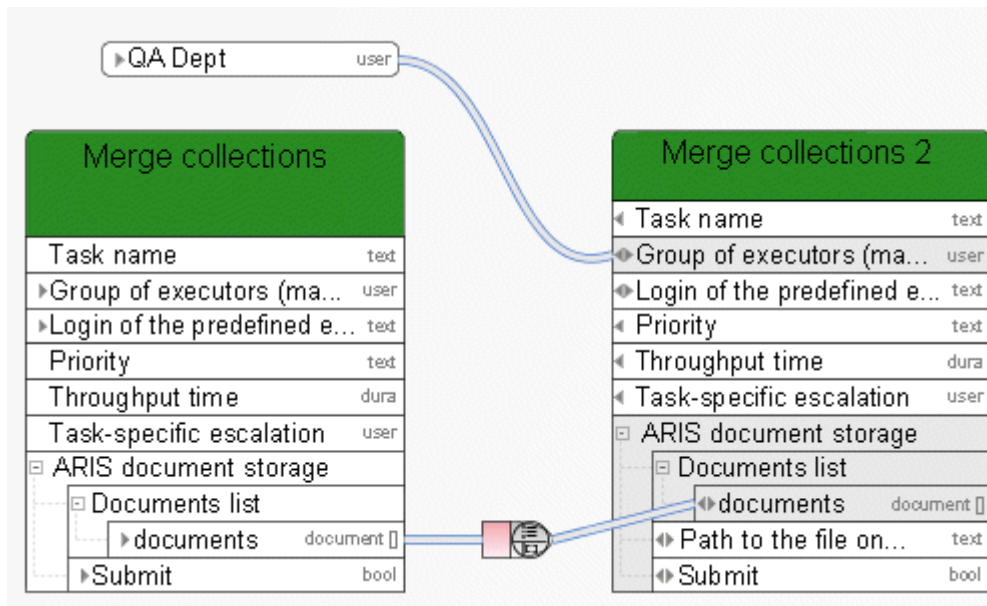

Figure 105: Validate collection

### 3.10.4.8 Merge collections



Creates a new collection (list, data series) of objects of the same type from two individual collections of objects of the same type. The new collection contains all objects while maintaining the original order. The objects of the first collection start the order.

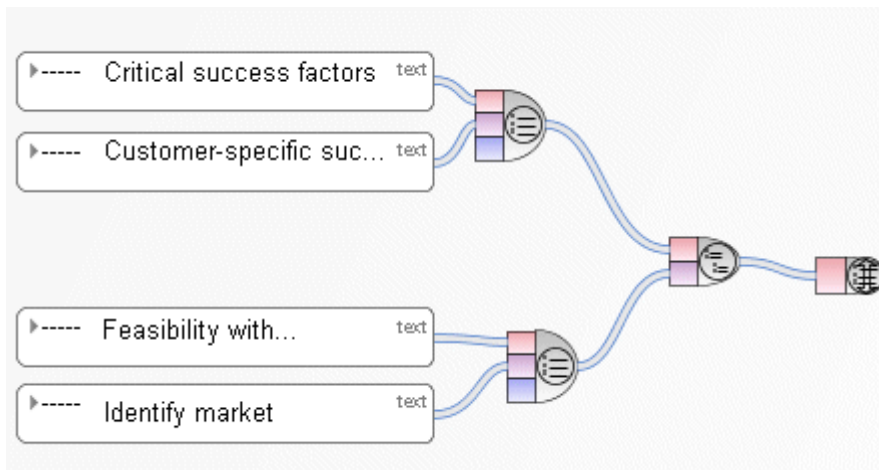



Figure 106: Merge collections

### 3.10.5 What are document operators?

Document-related operators in Process Governance data flows are tested and released for documents which are stored in ARIS document storage only and not for external document managements systems like Microsoft® SharePoint.

#### 3.10.5.1 Get document by path

 The operator offers the option to access a document in ARIS document storage via a physical path name. To do this, the user must have been created in ARIS Administration with the required privileges. The input data is a constant of the **collection of strings** type, containing the storage location of the document in ARIS document storage. The output data is of the **collection of documents** type.

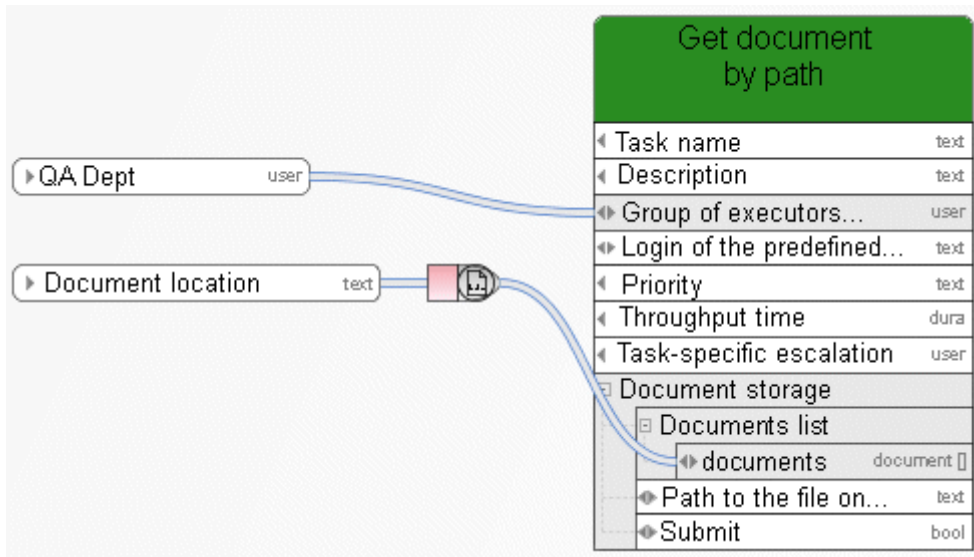

Figure 107: Get document by path

### 3.10.5.2 Get document metadata



All metadata is retrieved that can be placed with a constant of the type **Document metadata**, such as file name, title, or version number.

To specify the document, a connection is drawn to the first slot of the operator, and another connection is drawn to the second slot to specify the corresponding field in the document metadata.

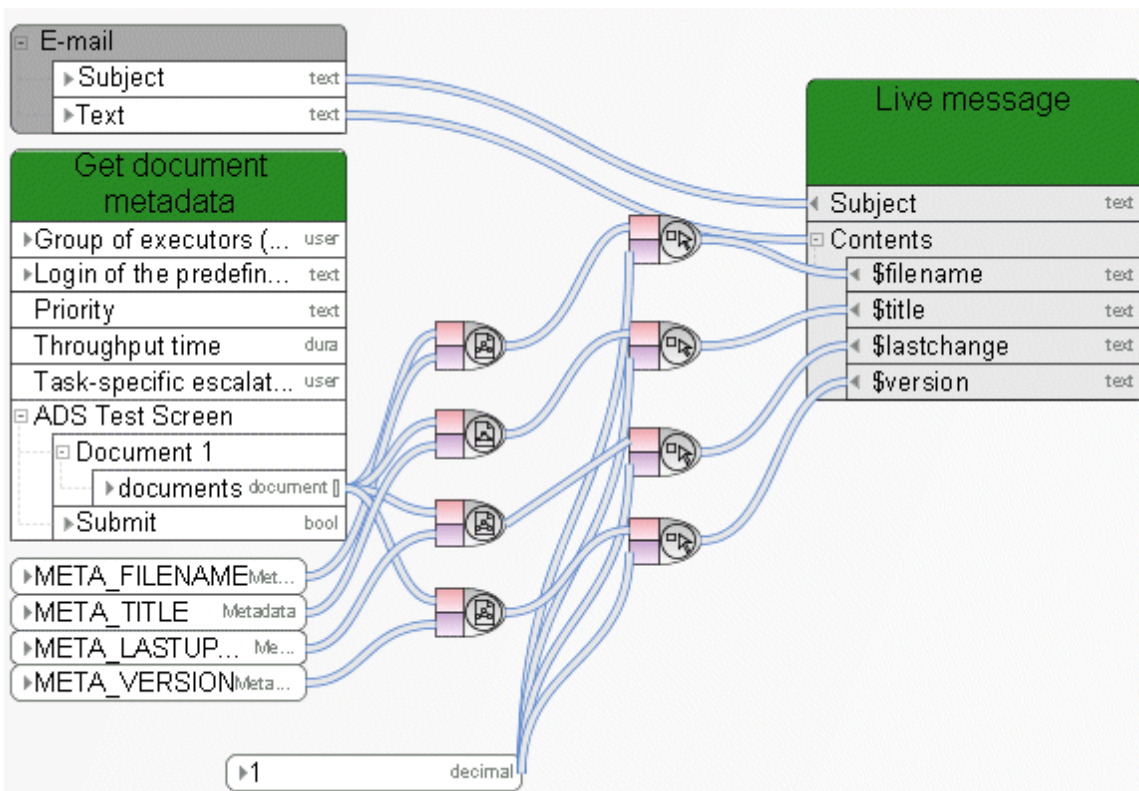



Figure 108: Get document metadata

### 3.10.5.3 Filter documents

 You can mark documents in ARIS document storage with tags. With this operator, you can filter a list of documents by name, version, and tag.

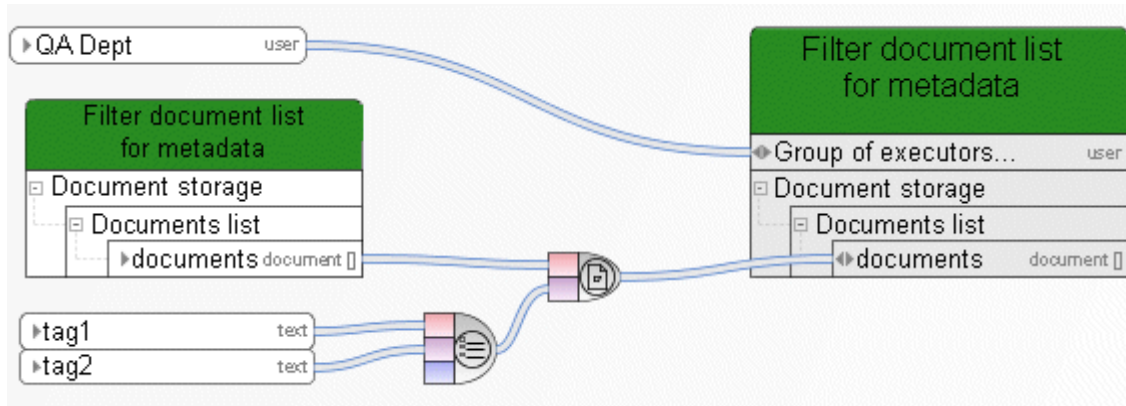



Figure 109: Filter documents

### 3.10.5.4 Generate http link for document

 Creates an HTTP link for a document or a list of documents stored in ARIS document storage. Input data is a list of documents, output data is a list of hyperlinks.

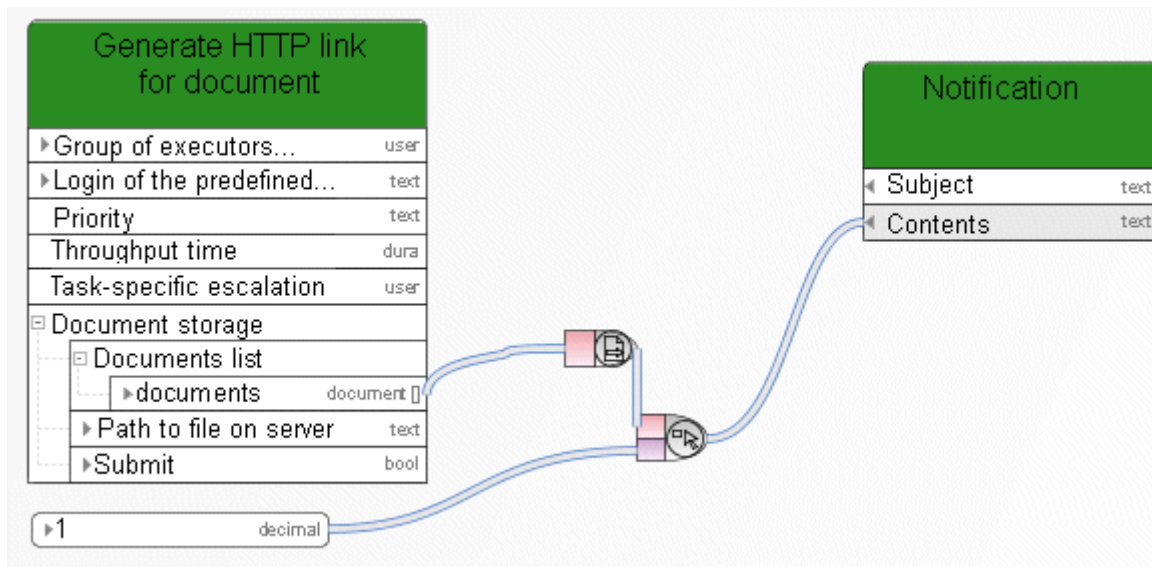

Figure 110: Generate http link for document

### 3.10.6 Data elements

#### 3.10.6.1 Path to ARIS Process Board



This operator returns the path to ARIS Process Board.

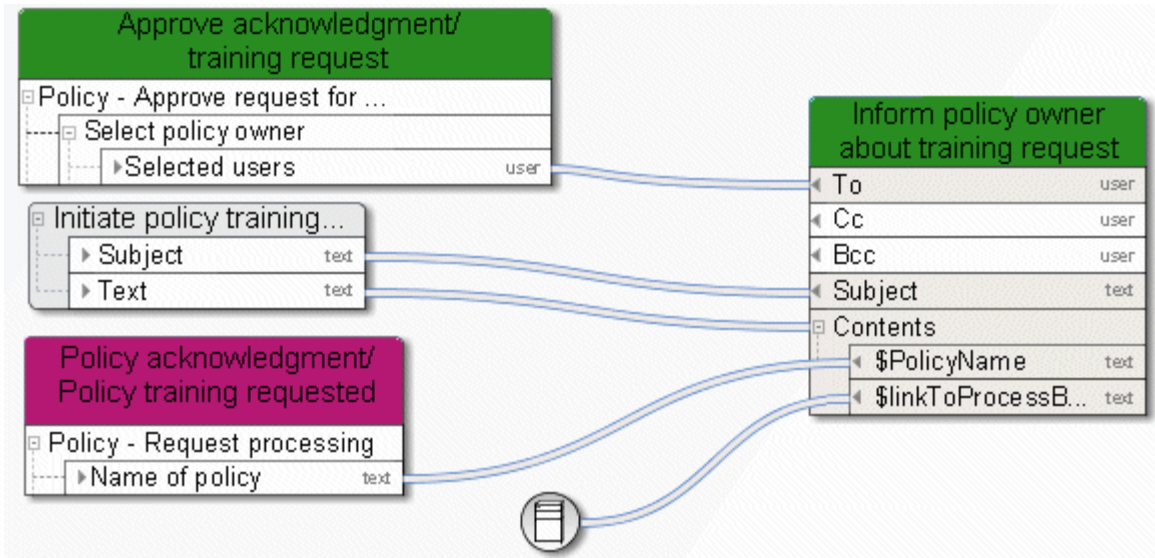

Figure 111: Path to ARIS Process Board

### 3.10.6.2 Get timestamp



This operator returns the current timestamp of the server (Date - Time) as UTC time. **Coordinated Universal Time**, refers to the coordinated global time.

You can calculate the Central European Time (CET) from the UTC time by adding an hour to it. For the Central European Summer Time (CEST) you must add 2 hours.

The **Convert timestamp or date to human readable text** (page 199) operator converts a UTC time to the time that corresponds with your time zone.

Please note: The server's timestamp may differ from the client's timestamp.

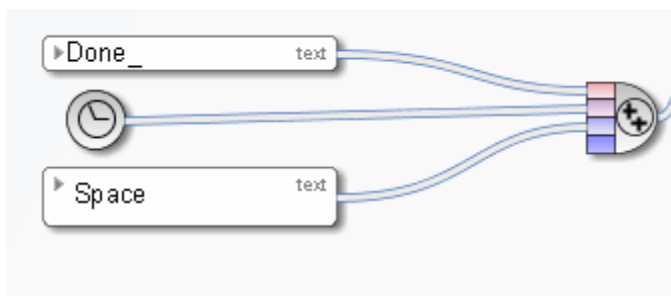

Figure 112: Get timestamp



## 3.10.7 Miscellaneous operators

### 3.10.7.1 Check whether user exists



The operator checks whether the user or user group exists in ARIS Administration. The input data is a scalar value representing either a user or a user group. If the user or user group exists in ARIS Administration, the operator returns **TRUE**. Otherwise, it returns **FALSE**.

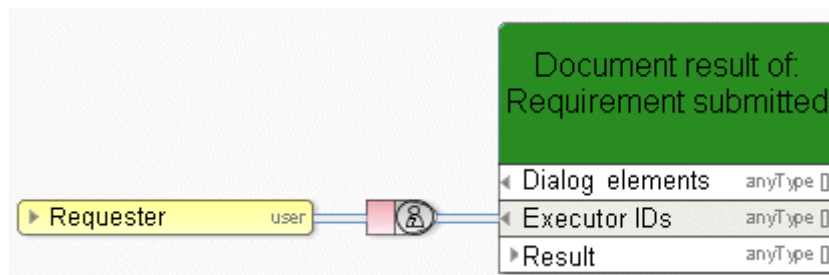

Figure 113: Check existence in ARIS Administration

### 3.10.7.2 Determine user via e-mail/login name



This operator identifies the user who has the specific name, user name, or e-mail address. E-mail: Standard SMTP e-mail address of the type **text**), e.g.: peter.smith@company.com.

The data is searched in this order: user name (person), e-mail address (person), name (role), name (organizational unit).

If this input data is unknown, the operator creates a new user. The output of the operator is a reference to this user, which can be used as input for tasks of the type **Notification** (To, Cc, Bcc) or **Human task** (group of executors).

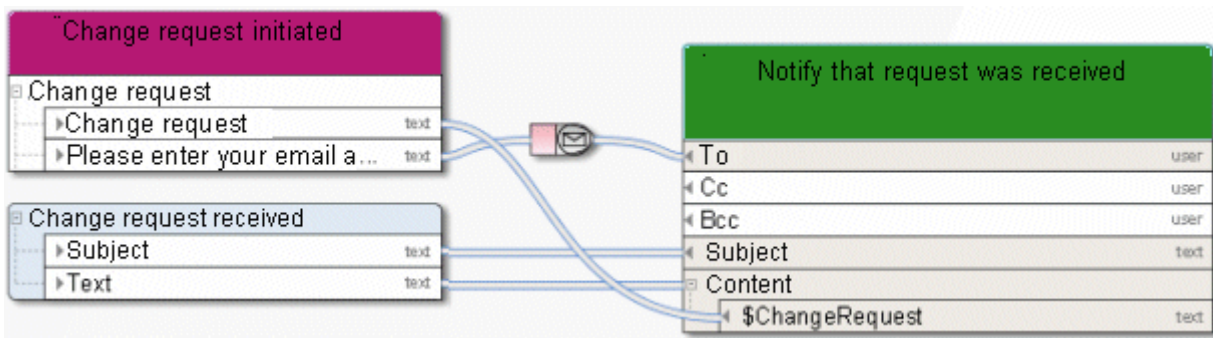

Figure 114: Determine user via e-mail/login name

### 3.10.7.3 Get committed resource



This operator accepts automation-relevant organizational elements (e. g., roles) as input and returns the persons who belong to these organizational elements and who participated in the workflow.

Example: The role **Modeler** consists of five members, but only one of these members has processed all of the **Human tasks** assigned to this role. Thus, this user is the only output of the operator **Get committed resource**.

This operator is automatically created when a data flow of a notification function is created and the connected organizational element has the attribute **Only inform people involved** (connection type **Must be informed about**).

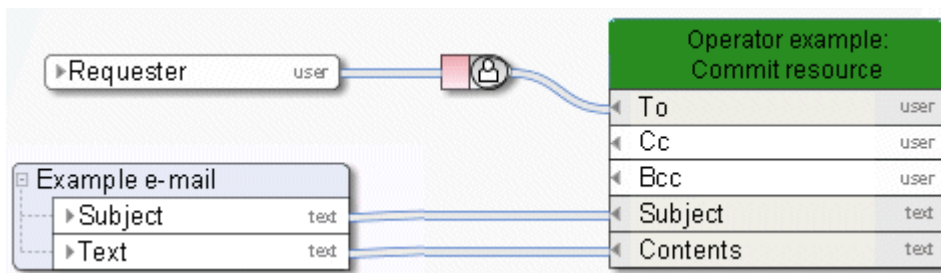

Figure 115: Get committed resource

### 3.10.7.4 Get participant name

 This operator converts the technical representation of an executor into their name.

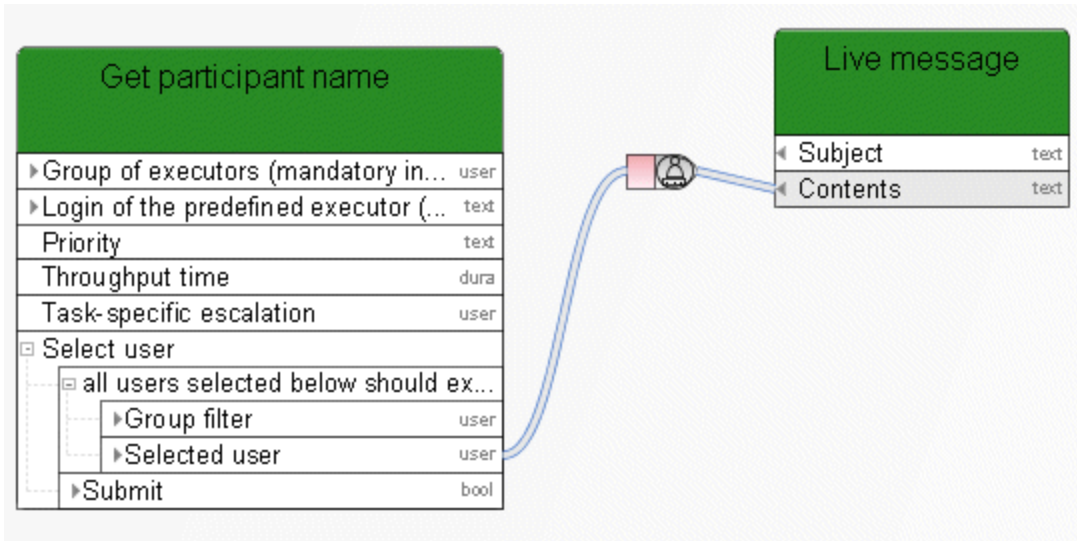



Figure 116: Get participant name

### 3.10.7.5 Concatenate

 Textual concatenation of values; here the concatenation between the result from the **Automated task** and the value of the variable **Log of entire history**.

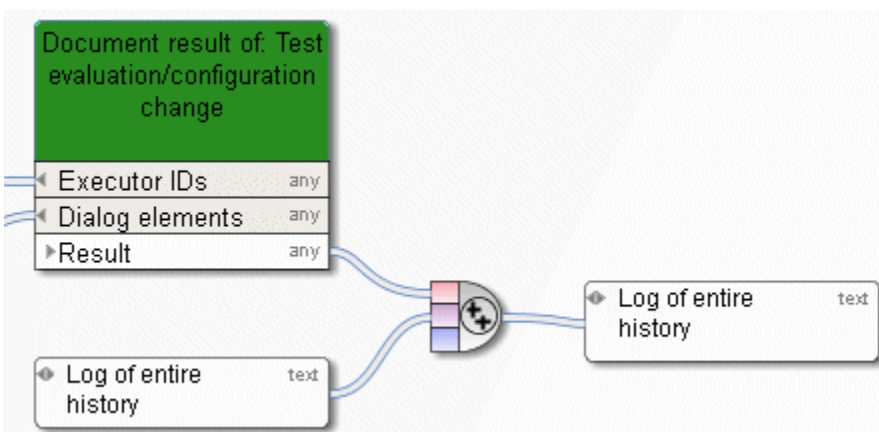

Figure 117: Concatenate

### 3.10.7.6 Convert timestamp or date to human readable text



This operator converts a Base64-encoded timestamp or a date into a readable string.

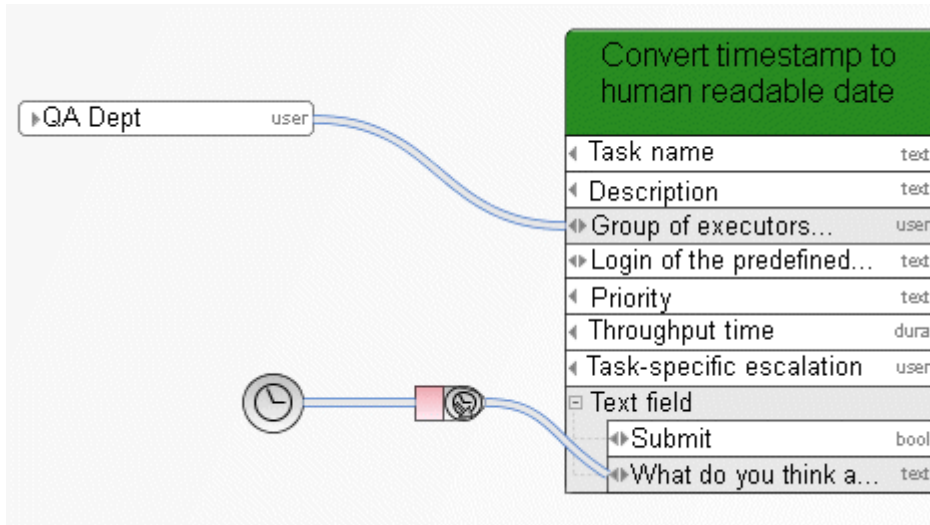
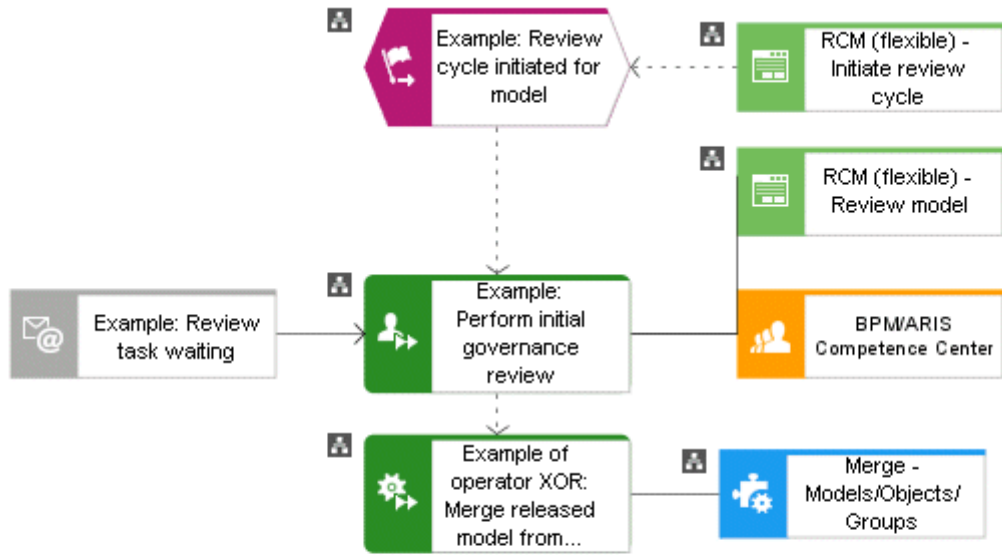

Figure 118: Convert timestamp or date to human readable text

### 3.10.7.7 Data XOR operator

**XOR** **Data OR (XOR):** Uses the first available input  
 The database name is determined by either the **Human task** (priority 1) or – if this returns no value – by **Event (process instance started)**.



Example of XOR operator: Merge released model from review database into release database

AND

Example: Perform initial governance review	released model from Review into Release database
RCM (flexible) - Review...	Database name text
Review database text	* Database language text
	User login text
	Password password
	Selected items
	* Identification text []
	* Target database text
	Merge attributes bool
	Assignment level decimal
	Assignment outsid... bool
	Connection outsid... bool
	Models: Source over... bool

Figure 119: XOR

### 3.10.7.8 Calculate time



This operator calculates an end date based on a start date and a duration.

A **Timer event** is delayed by 18 hours up from the point in time that the process instance reached this event.

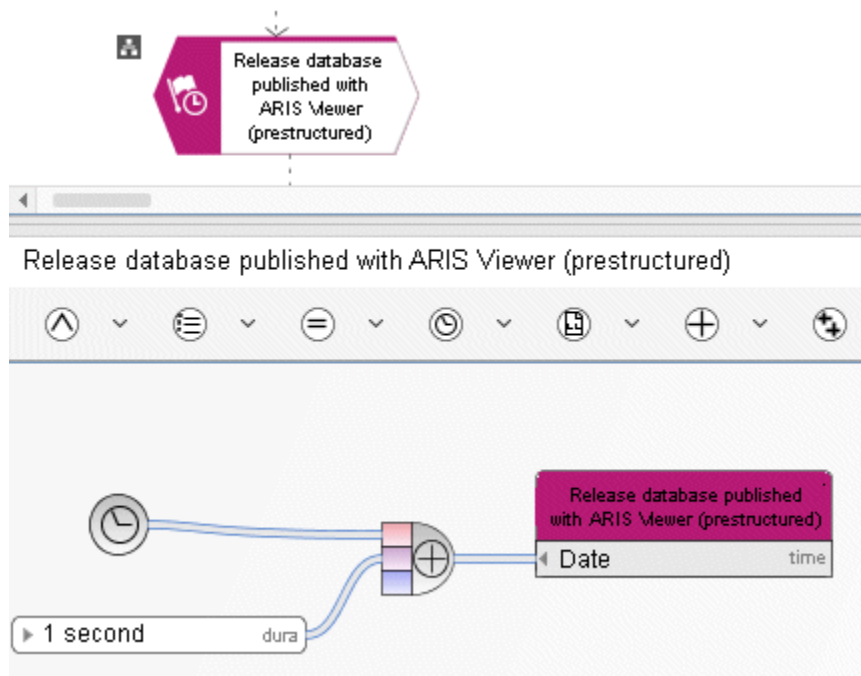

Figure 120: Calculate time

### 3.11 Constants

Constants are data sources with a fixed value. The value is not calculated at runtime, but rather at design time when the user models the process. Constants are only evaluated once during the creation of an executable process.

The value of a constant is not language-dependent. If the value of a constant should be language-dependent, please do not enter a value. In this case, the value of the constant is extracted from the name. The name is always language-dependent.

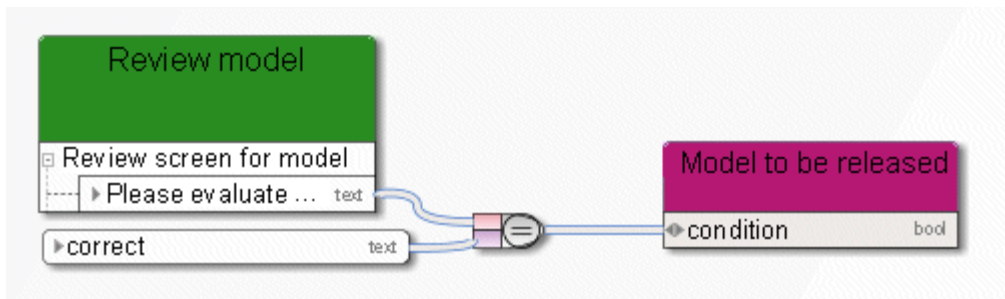

Figure 121: Constants



## 3.12 Variables

Variables are task-independent data placeholders. A function or an event can store a value in a variable, and another function or event can extract and use this value in a later process step. Please use variables only if absolutely necessary. An extended usage of variables can have significant negative impact on the performance of Process Governance.

### Example:

When a process is started, the executing user enters his e-mail address into the start dialog. The content from the e-mail text field of the variable is assigned in the assigned data flow of **Event (process instance started)**. Later, the e-mail address stored in the variable is used as input for subsequent notification functions, in order to provide the executing user with information about the status of the process.

### 3.12.1 Instance variable

This is the most common application of variables. The content (value) of the variables is shared by all activities of the currently active process instance. This variable can have a different value in each running process instance.

### Example:

In variables of the **String** type, information on which user entered what comment while editing a task is constantly updated.

### 3.12.2 Process variable

All activities in all instances of the currently active executable process share the content (value) of these variables.

### Example:

A counter that is incremented by one each time a process instance starts and decremented by one when a process instance terminates. The variable reflects the number of currently active process instances.

### 3.12.3 System variable

All functions in all executable processes and all their currently active instances share the content (value) of these variables. All activities can access this value directly.

### Example:

Host name or current time.

### 3.12.4 Examples

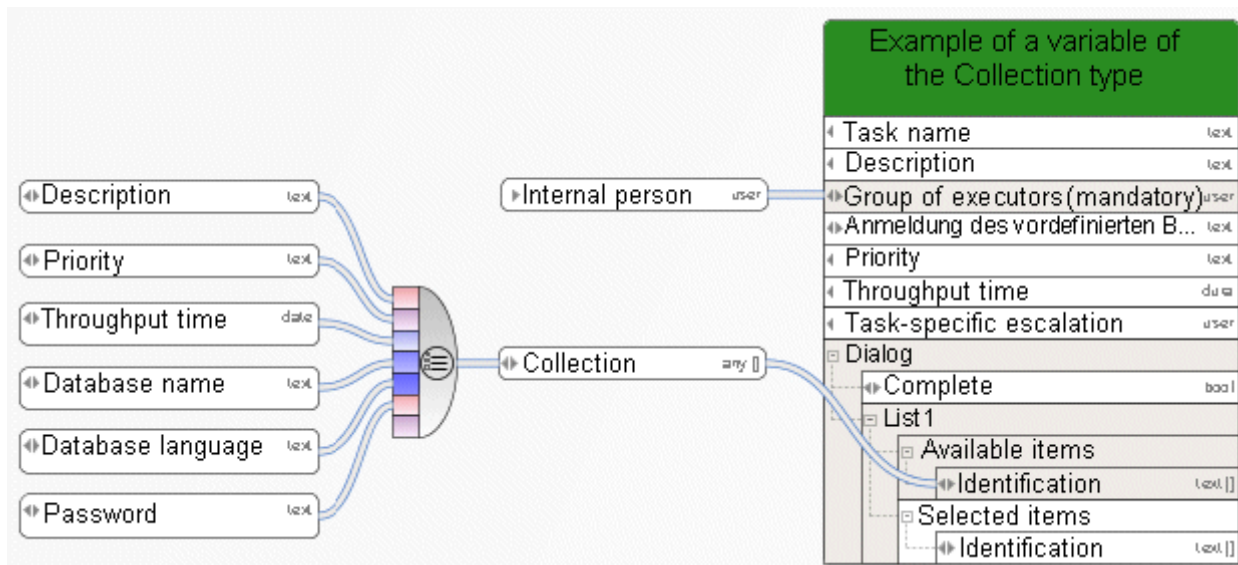

Figure 122: Example of a variable of the Collection type

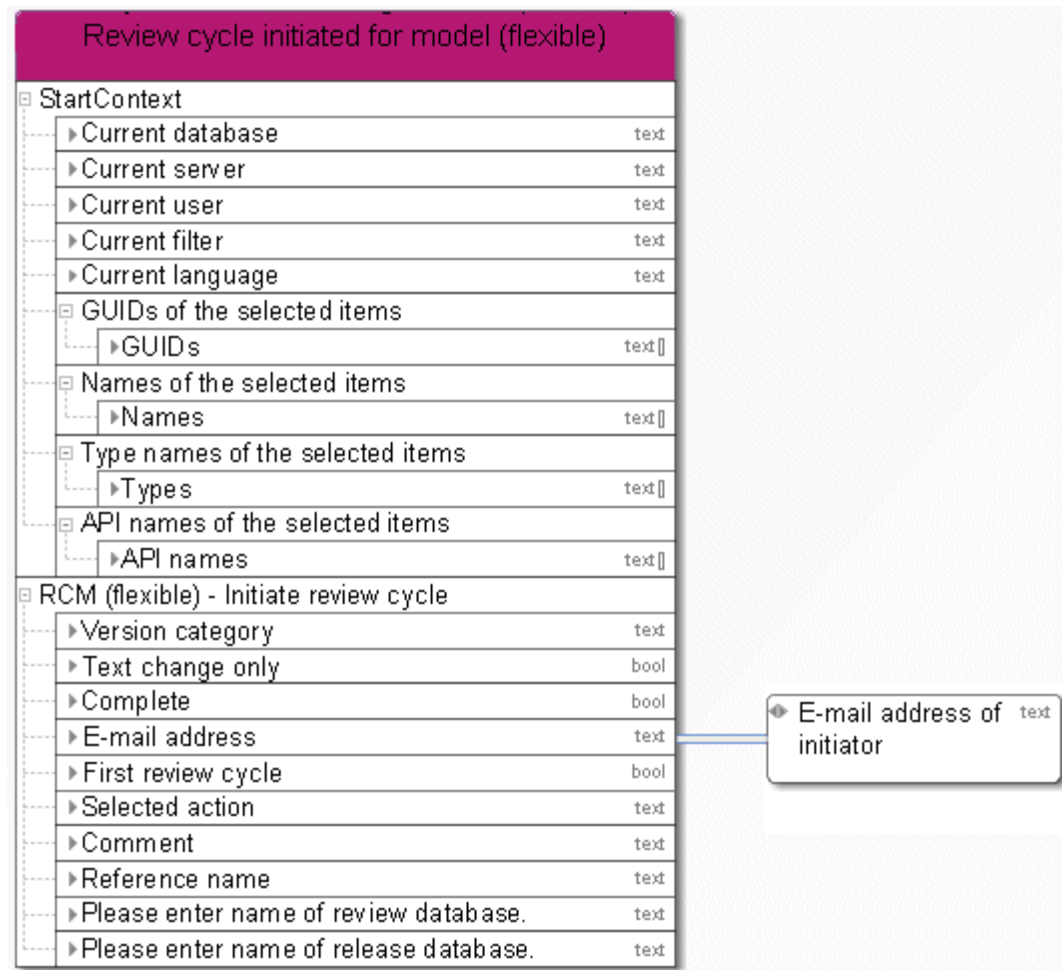

Figure 123: Example 1 - E-mail as output

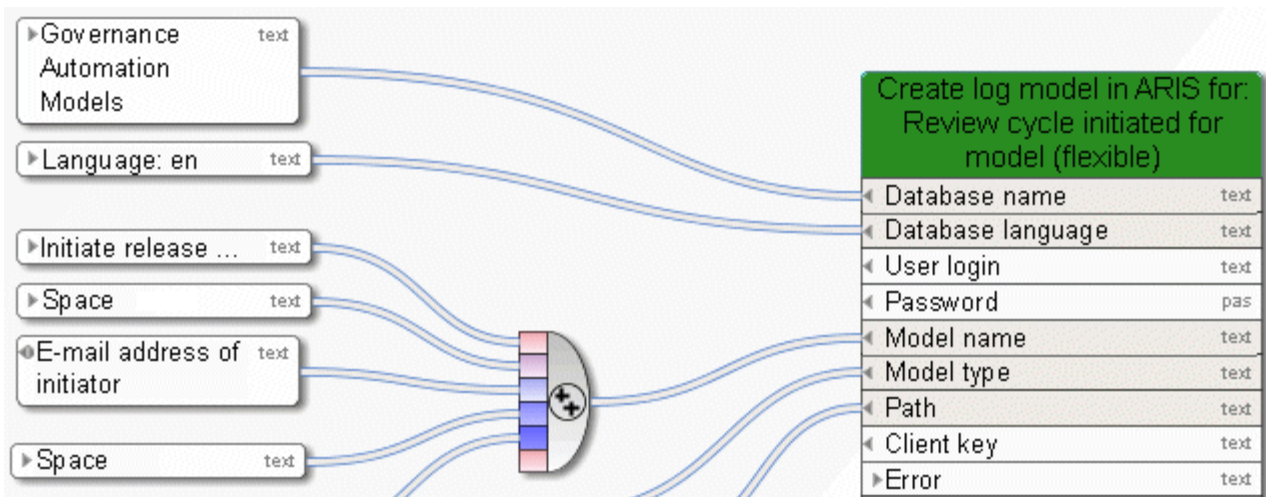

Figure 124: Example 1 - E-mail as input

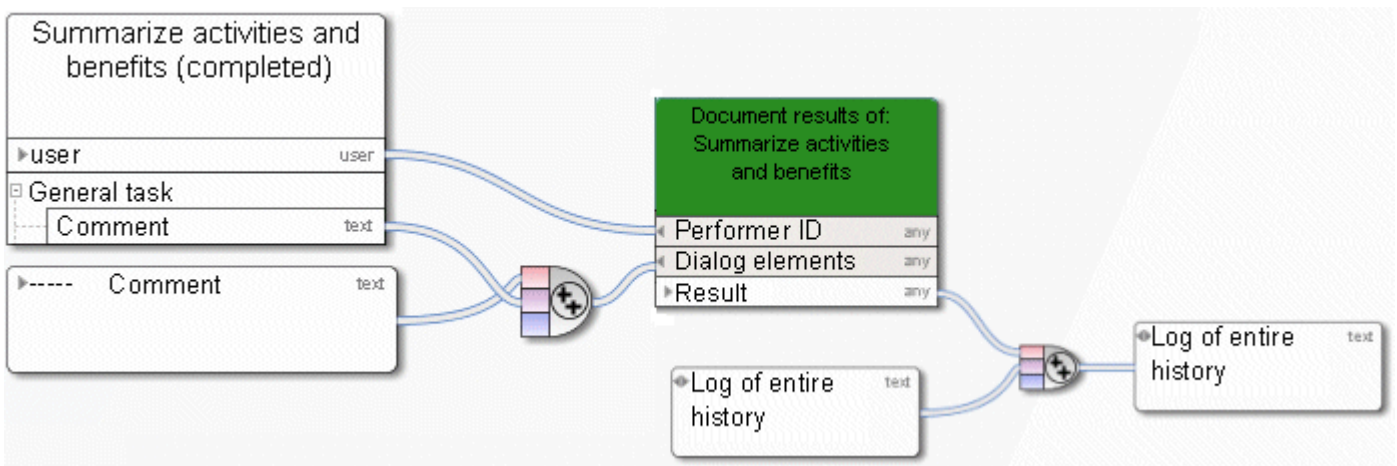

Figure 125: Example 2 – Document results of human task

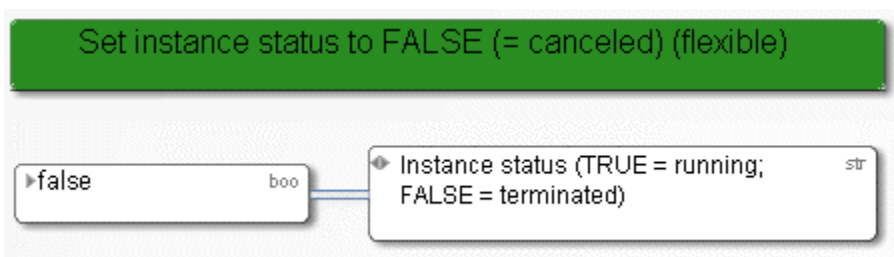

Figure 126: Example 3 – Set variable

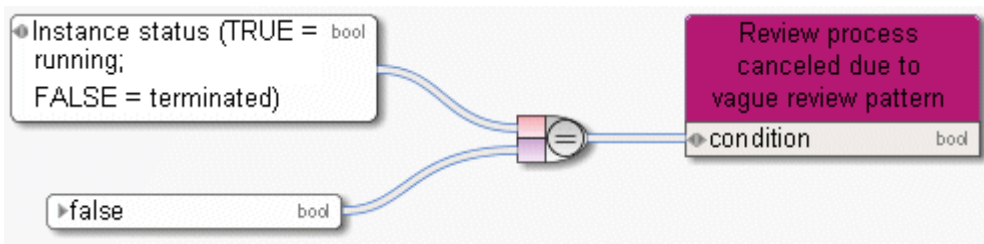

Figure 127: Example 3 – Read variable

## 4 Disclaimer

ARIS products are intended and developed for use by persons. Automated processes, such as the generation of content and the import of objects/artifacts via interfaces, can lead to an outsized amount of data, and their execution may exceed processing capacities and physical limits. For example, processing capacities are exceeded if models and diagrams transcend the size of the modeling area or an extremely high number of processing operations is started simultaneously. Physical limits may be exceeded if the memory available is not sufficient for the execution of operations or the storage of data.

Proper operation of ARIS products requires the availability of a reliable and fast network connection. Networks with insufficient response time will reduce system performance and may cause timeouts.

If ARIS products are used in a virtual environment, sufficient resources must be available there in order to avoid the risk of overbooking.

The system was tested using scenarios that included 100,000 groups (folders), 100,000 users, and 1,000,000 modeling artifacts. It supports a modeling area of 25 square meters.

If projects or repositories are larger than the maximum size allowed, a powerful functionality is available to break them down into smaller, more manageable parts.

Some restrictions may apply when working with process administration, ARIS Administration, ARIS document storage, and ARIS Process Board, and when generating executable processes. Process Governance has been tested and approved for 1000 parallel process instances. However, the number may vary depending on process complexity, e.g., if custom reports are integrated.

ARIS document storage was tested with 40.000 documents. We recommend monitoring the number and overall size of stored documents and if needed some documents should be archived.