

Format and Record Buffer Examples

This section provides examples of format and record buffer construction. For the Adabas file definitions used in all the examples in this section, see *File Definitions Used in Examples*.

This chapter covers the following topics:

- Example 1: Using Elementary Fields (Standard Length and Format)
- Example 2: Using Elementary Fields (Length and Format Override)
- Example 3: A Reference to a Periodic Group
- Example 4: The First Two Occurrences of Periodic Group GB
- Example 5: The Sixth Value of the Multiple-Value Field MF
- Example 6: The First Two Values of the Multiple-Value Field MF
- Example 7: The Highest Occurrence Number of a Periodic Group GC and the Existing Number of Values for the Multiple-Value Field MF

Example 1: Using Elementary Fields (Standard Length and Format)

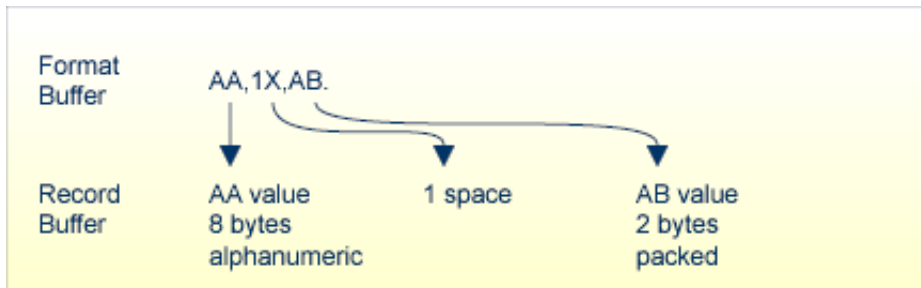

Example 2: Using Elementary Fields (Length and Format Override)



Example 3: A Reference to a Periodic Group

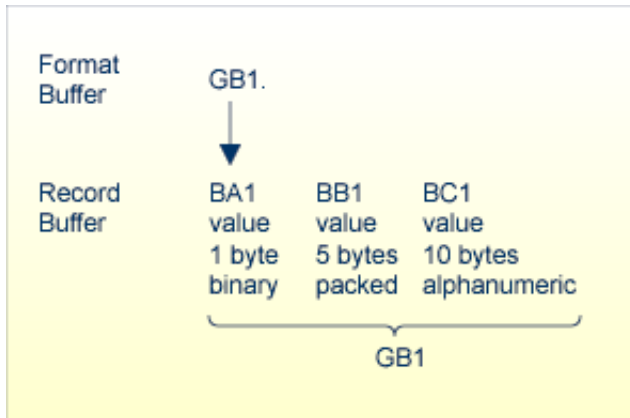

Example 4: The First Two Occurrences of Periodic Group GB

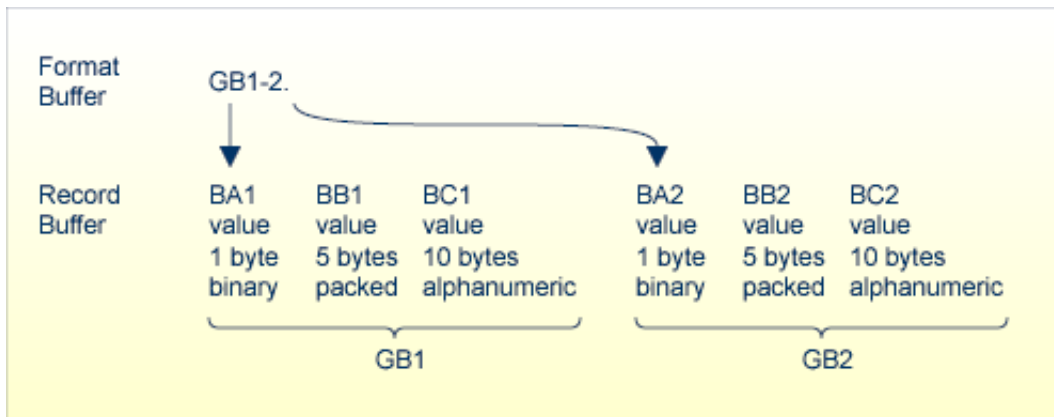

Example 5: The Sixth Value of the Multiple-Value Field MF



Example 6: The First Two Values of the Multiple-Value Field MF

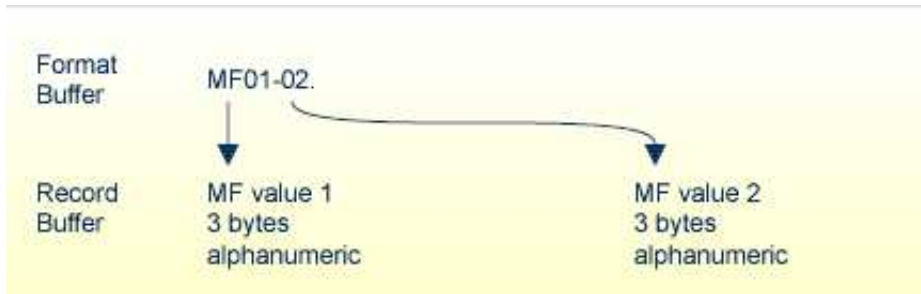

Example 7: The Highest Occurrence Number of a Periodic Group GC and the Existing Number of Values for the Multiple-Value Field MF

